

Vorspannung Einführung Teil 2

Kabelvorspannung im Brückenbau

Kabelvorspannung im Brückenbau

Beispiele / Fotos:

Viadukt Glattzentrum (2009)

Innbrücke Vulpera (2010)

Versamertobelbrücke (2012)

Steinbachviadukt (2014)

Kabelvorspannung im Brückenbau

Beispiele / Fotos:

Viadukt Glattzentrum (2009)

Innbrücke Vulpera (2010)

Versamertobelbrücke (2012)

Steinbachviadukt (2014)



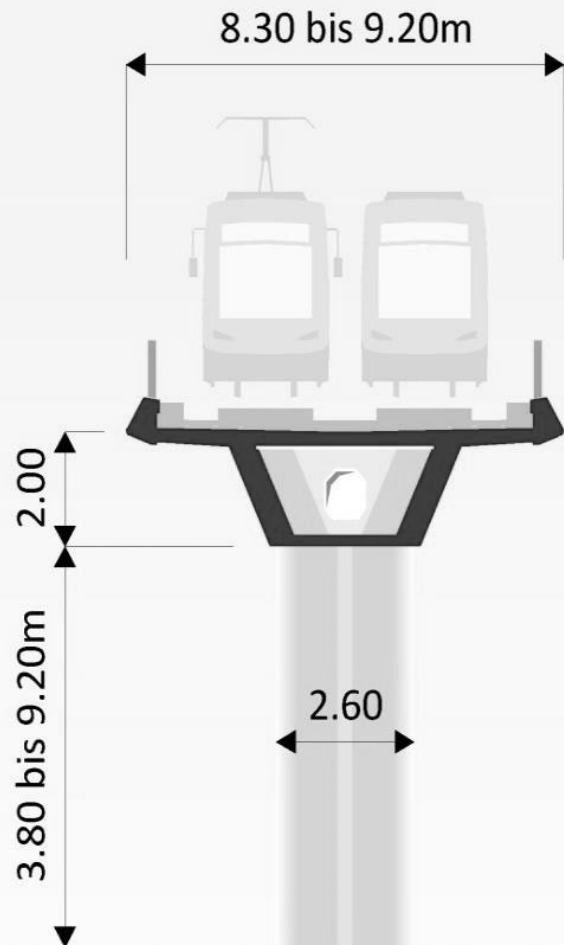

2 Pfähle ø120cm





VORSPANNLAYOUT 1:200 Vorspannkabel pro Steg

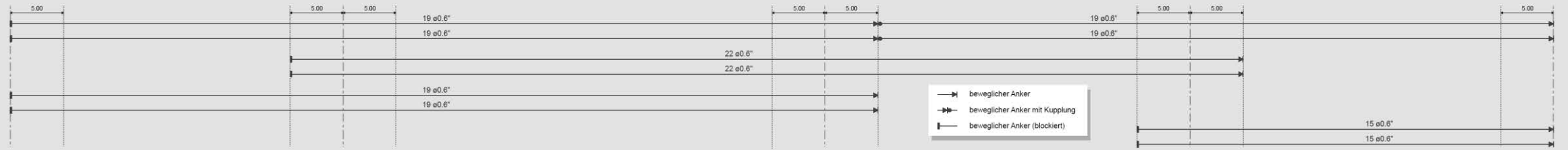

LÄNGSSCHNITT 1:200

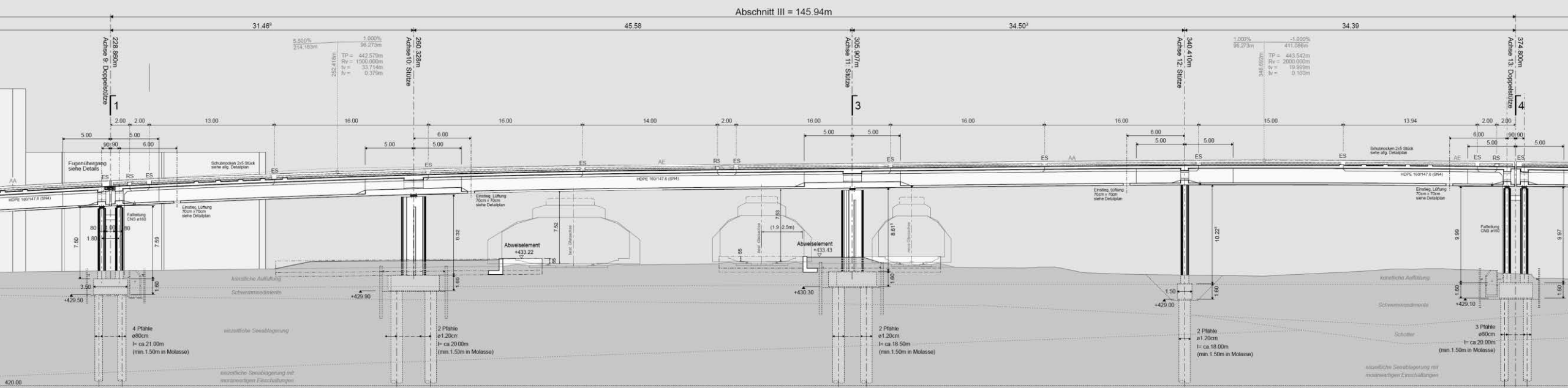

Grundriss, 1 : 100
 Etappe III.1 Kabel V1-2, V3-2, V2-2 + V2-3

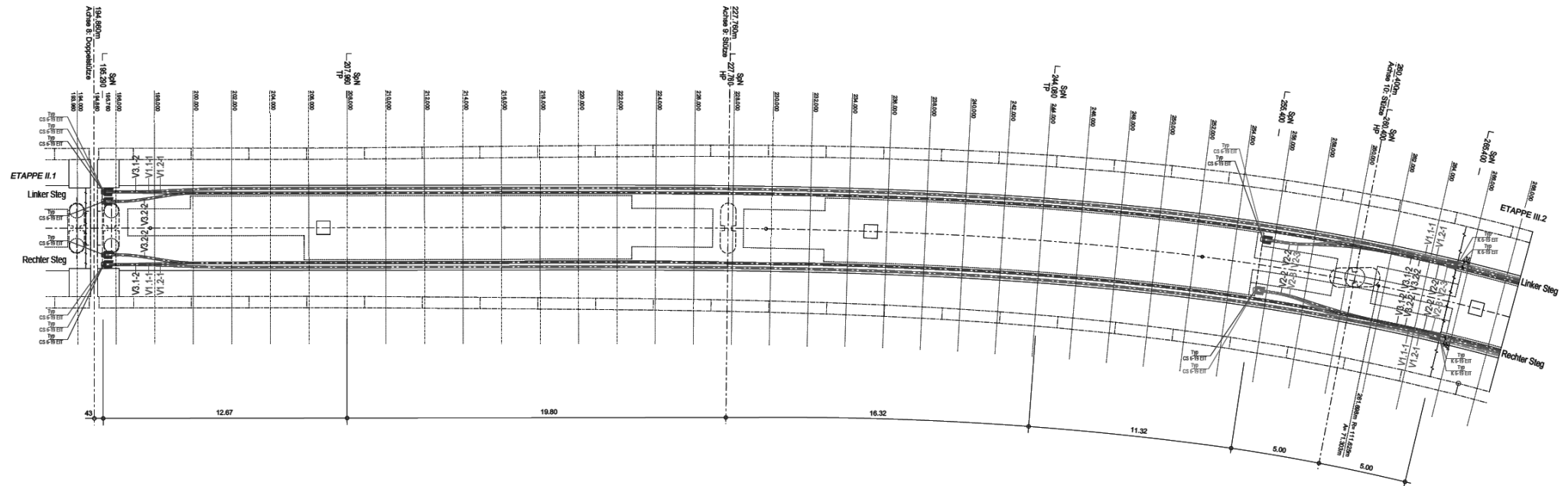

Längsschnitt, 1 : 100
 Etappe III.1 Brückenachse

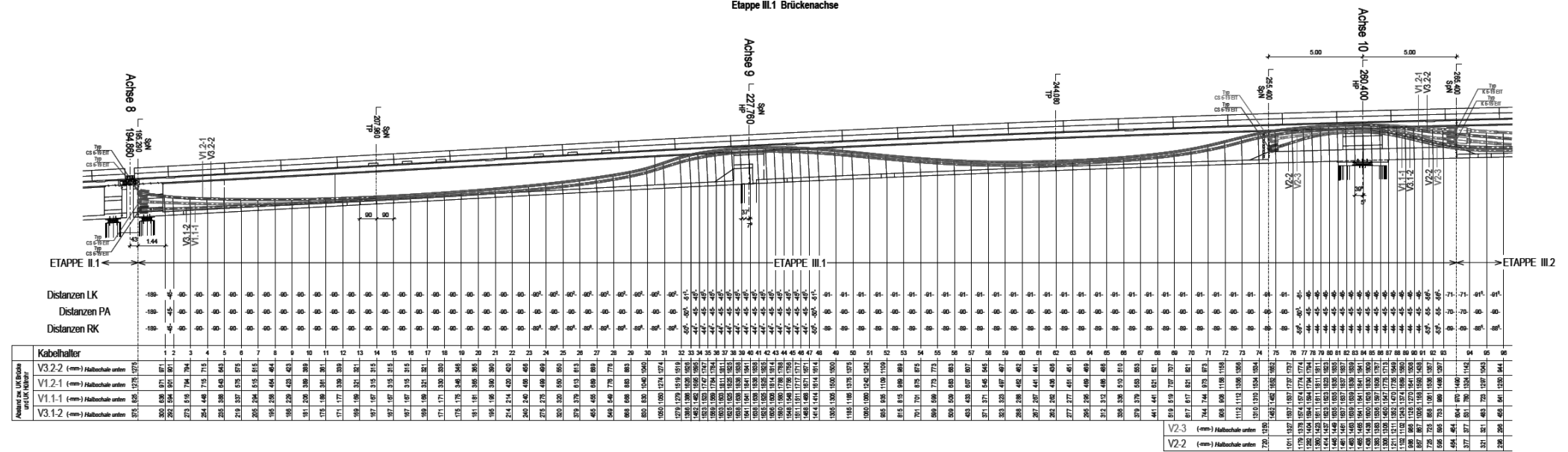

Längsschnitt, 1 : 100

Etappe III.1 Brückenachse

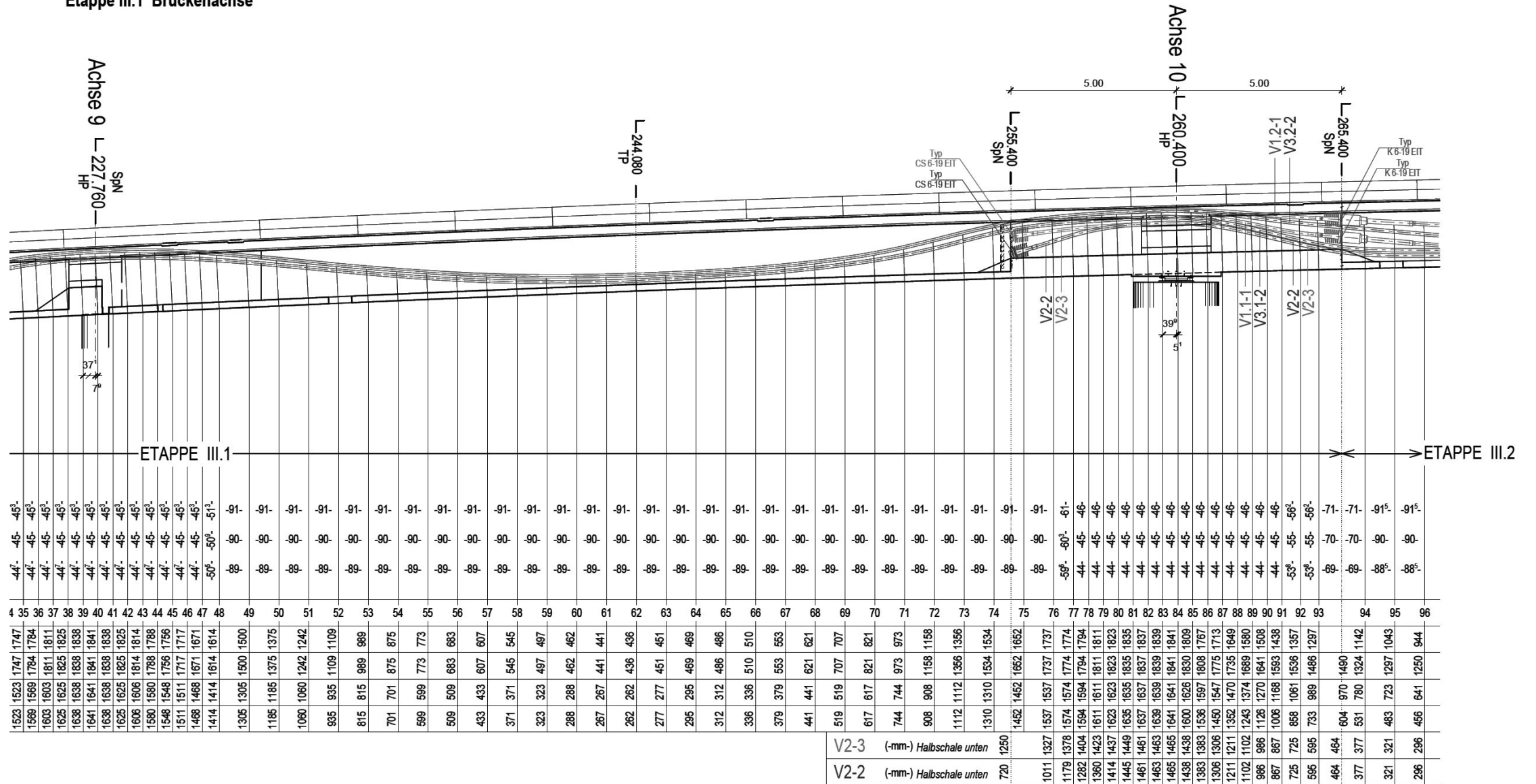

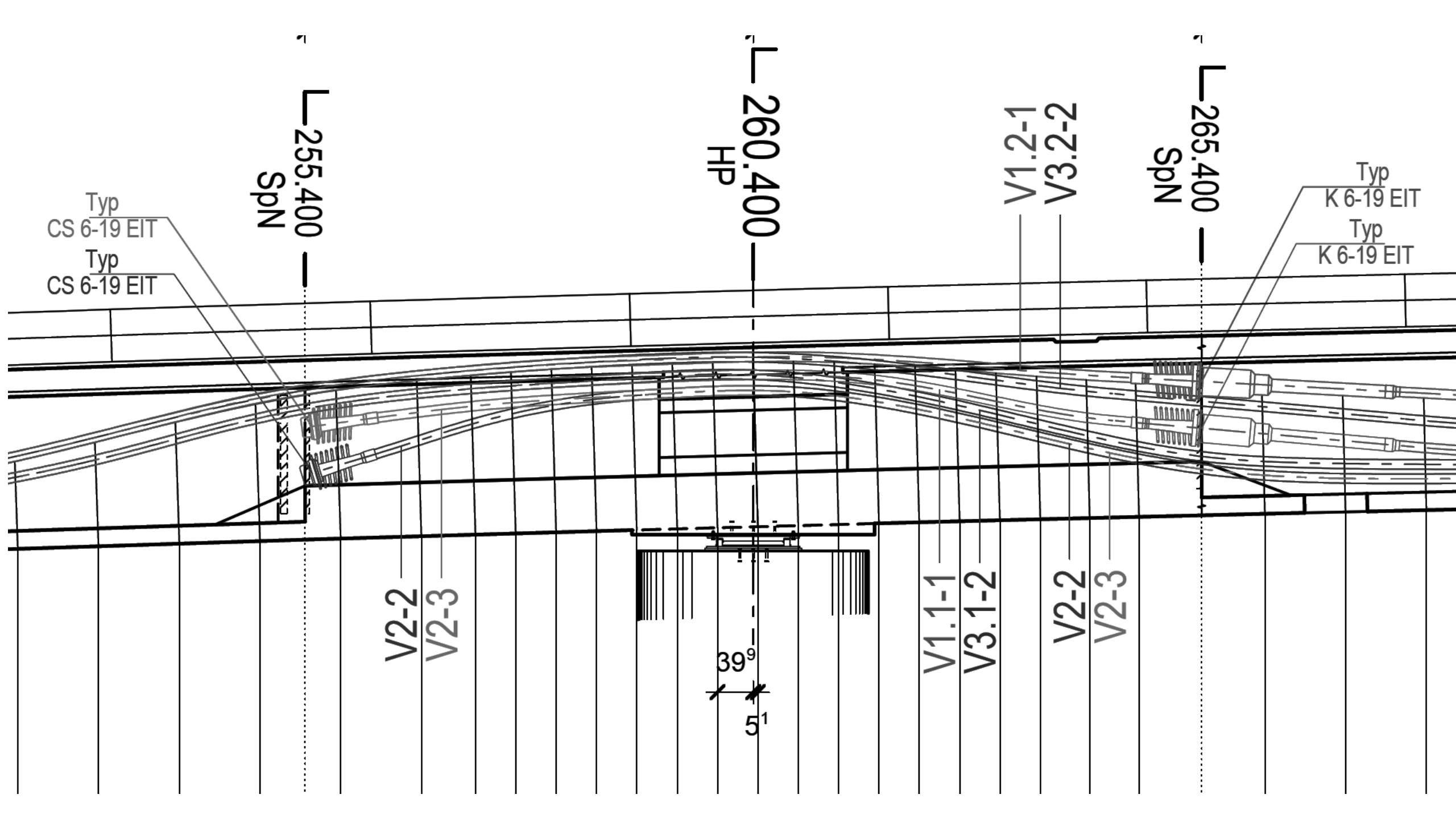

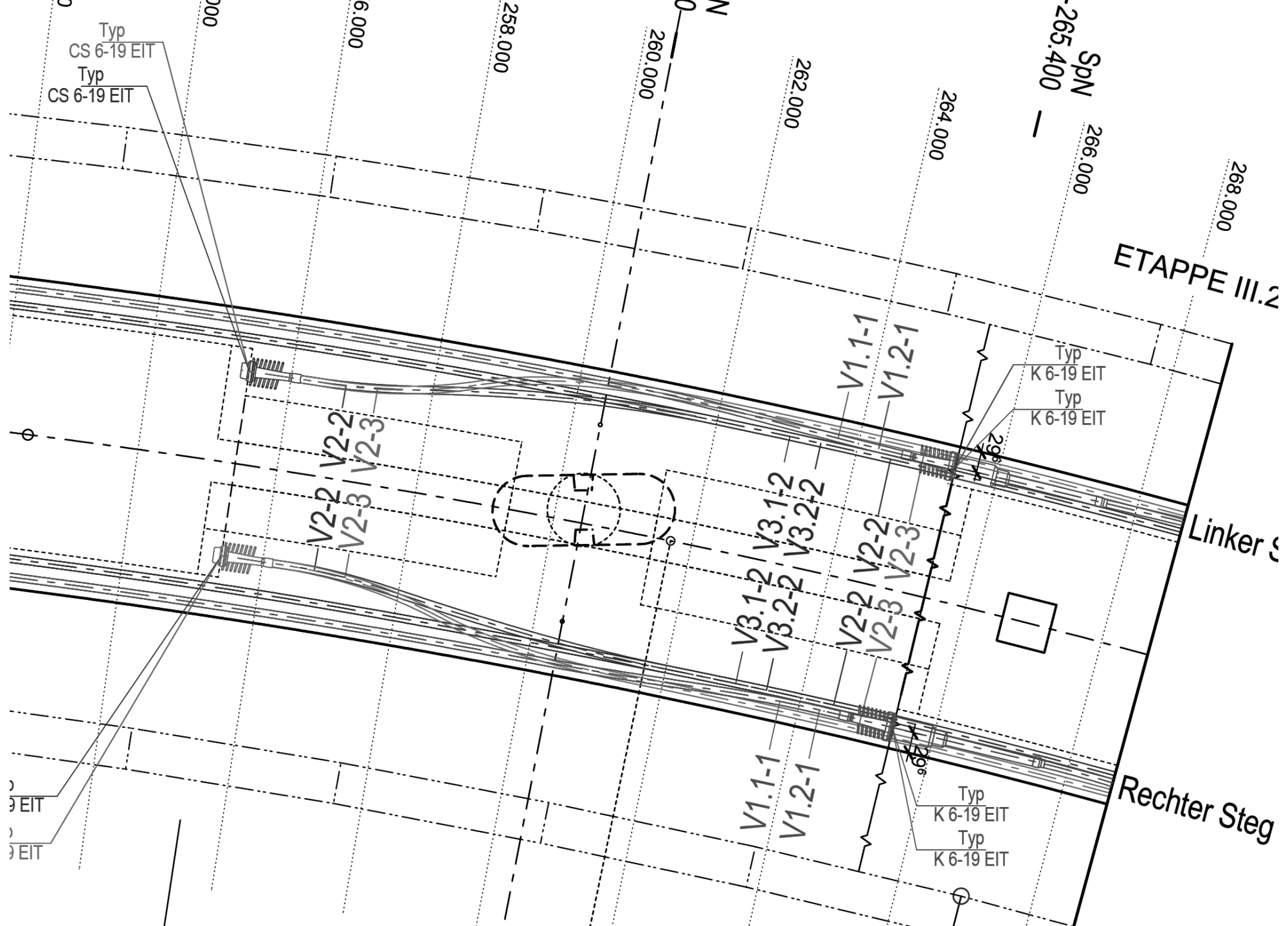

142

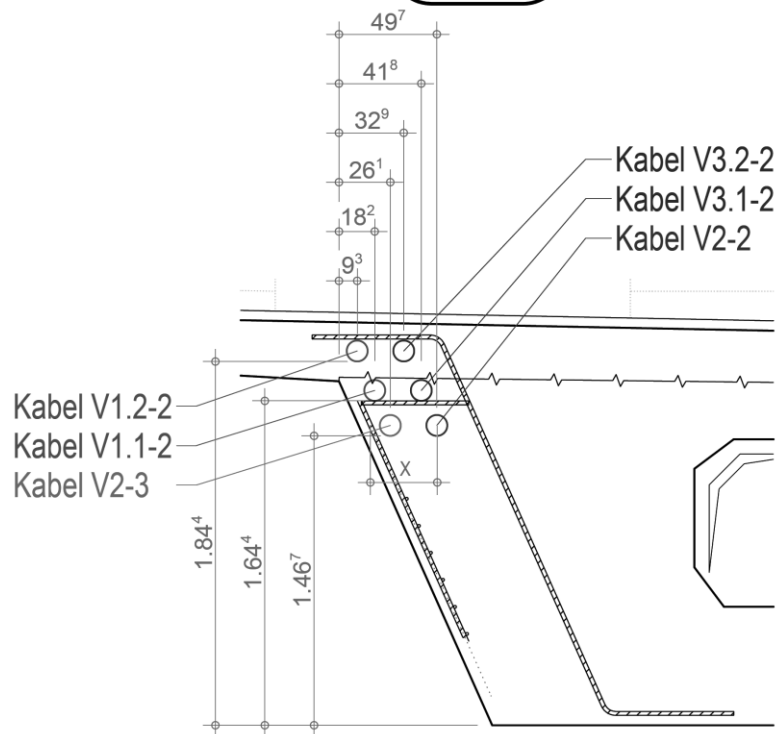

	Kabel	Abstand (mm)
Abstand zw. Achse vertikal Eisen und Achse Hüllrohr (x)	V3.2-2	337
	V1.2-2	101
	V1.1-2	101
	V3.1-2	337
	V2-3	101
	V2-2	337

151

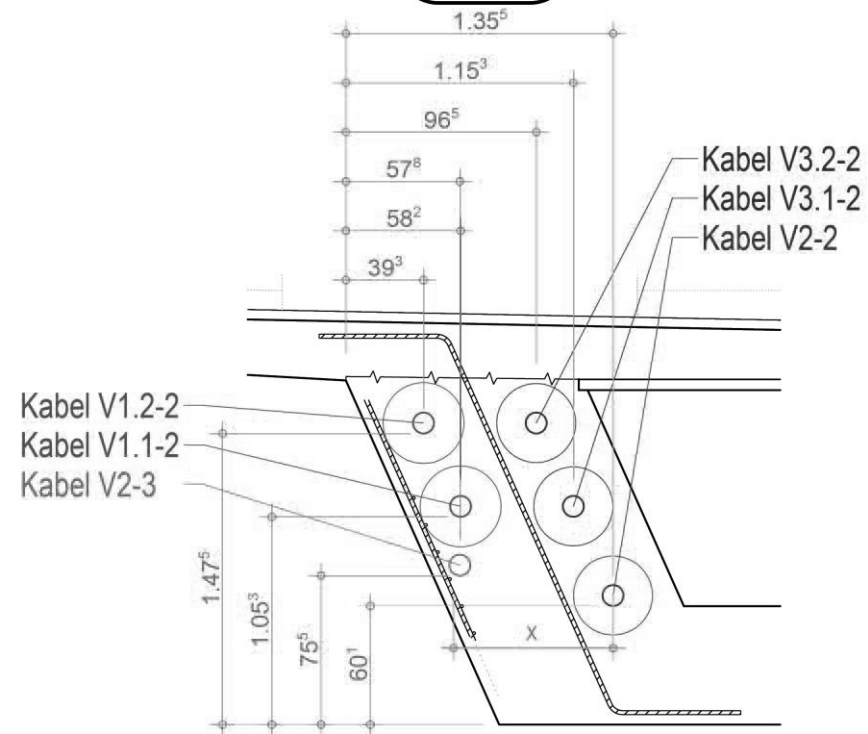

	Kabel	Abstand (mm)
Abstand zw. Achse vertikal Eisen und Achse Hüllrohr (x)	V3.2-2	808
	V1.2-2	237
	V1.1-2	237
	V3.1-2	808
	V2-3	101
	V2-2	808

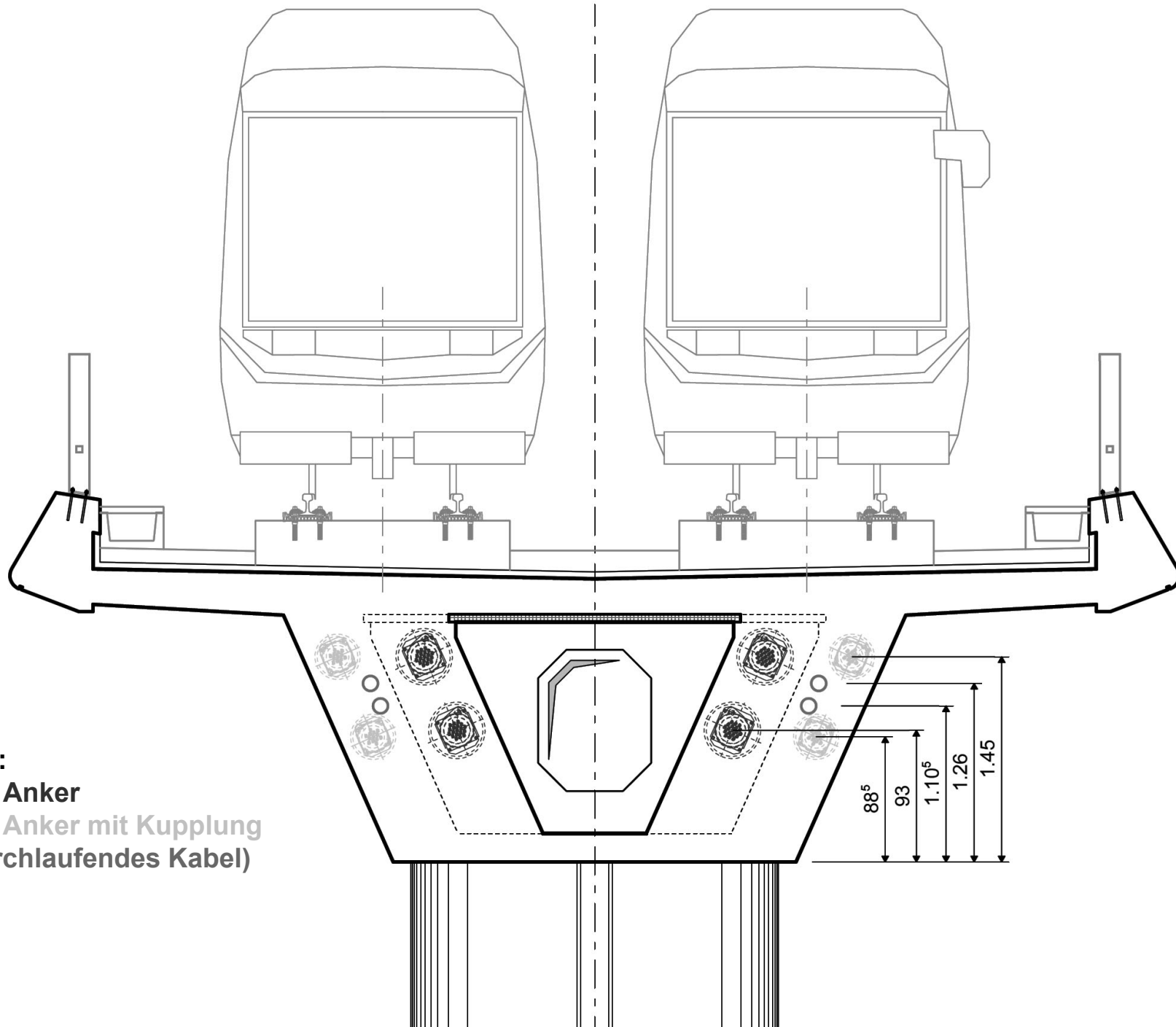

Farblegende:
 Beweglicher Anker
 Beweglicher Anker mit Kupplung
 Hüllrohr (durchlaufendes Kabel)







































Installation der Spannglieder

Variante 1: Im Werk vorgefertigte Spannglieder (heute selten)

- Drähte möglich, Spanngliedlänge muss aber exakt vorausberechnet werden
- Einsatz einfacher fester Verankerungen möglich

Variante 2: Baustellenfabrikation

- Einstossen der einzelnen Litzen ins Hüllrohr vor / nach dem Betonieren oder Einziehen des Litzenbündels mit einer Seilwinde nach dem Betonieren
(Hüllrohre gegen Aufschwimmen sichern!)

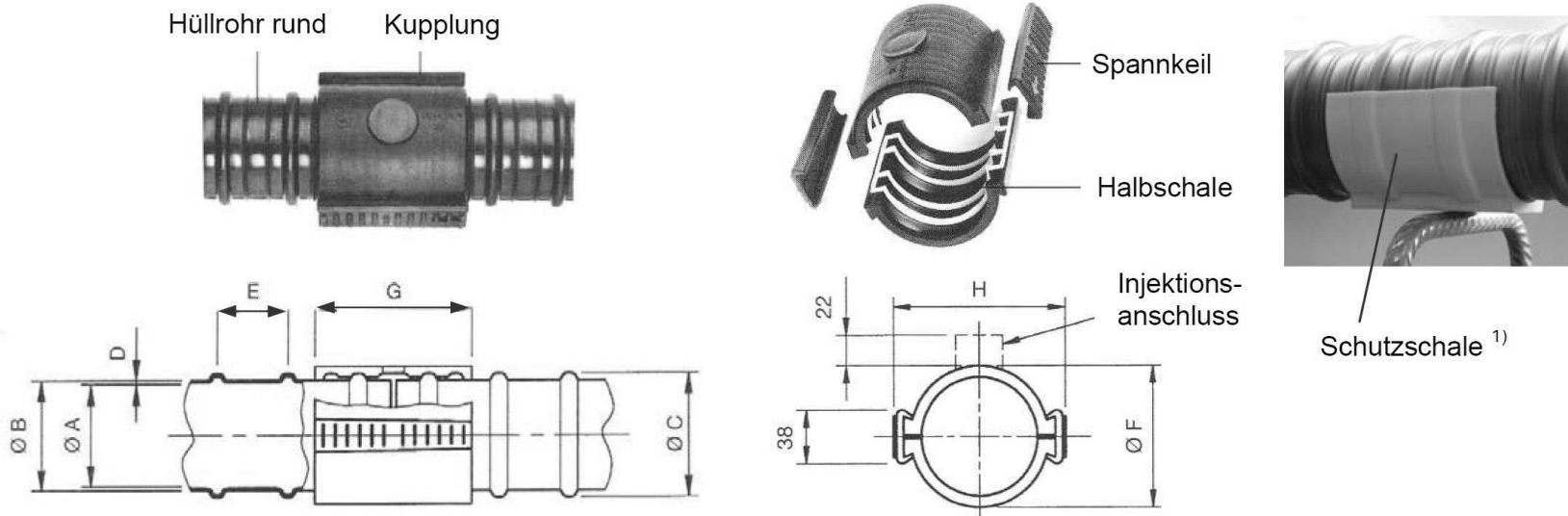

Hüllrohre

Stahlhüllrohre

- aus Bandblech geformt $\varnothing_a \approx \varnothing_i + 6$ mm
- konventionelle Lösung
- etwas geringere Kosten
- etwas kleinerer Platzbedarf

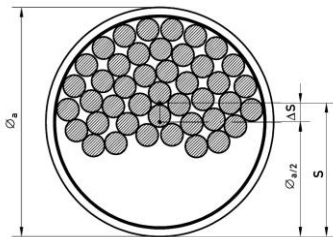

Kunststoffhüllrohre

- Wandstärke 2-3 mm, Rippung
- erhöhter Korrosionsschutz
- besseres Ermüdungsverhalten
- elektrische Isolation möglich

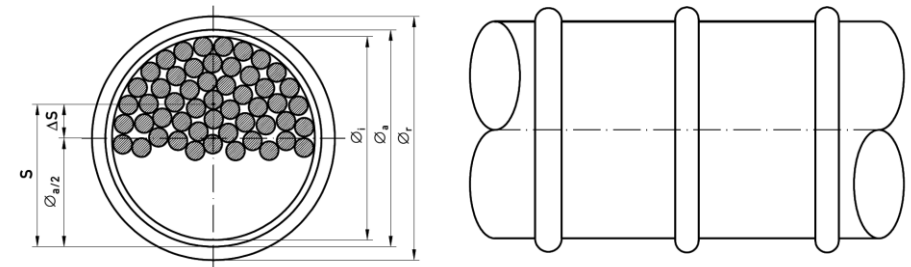
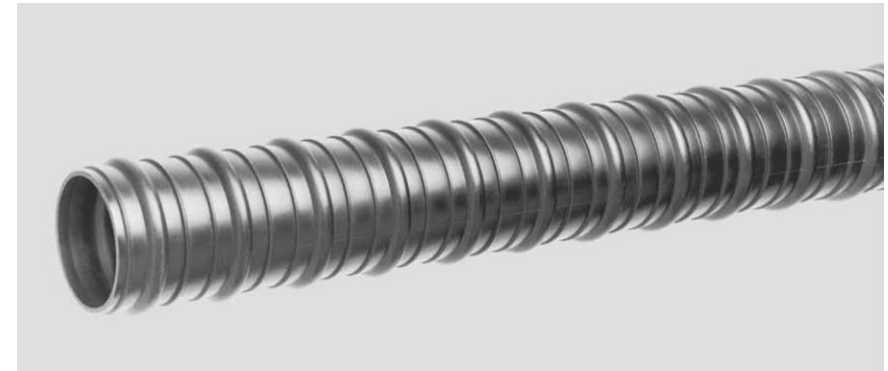





Vorspannung – Einführung

Interne Kabelvorspannung mit Verbund – Spannbare Verankerungen

Verankerung mit Ankerplatte
(VSL Typ E)

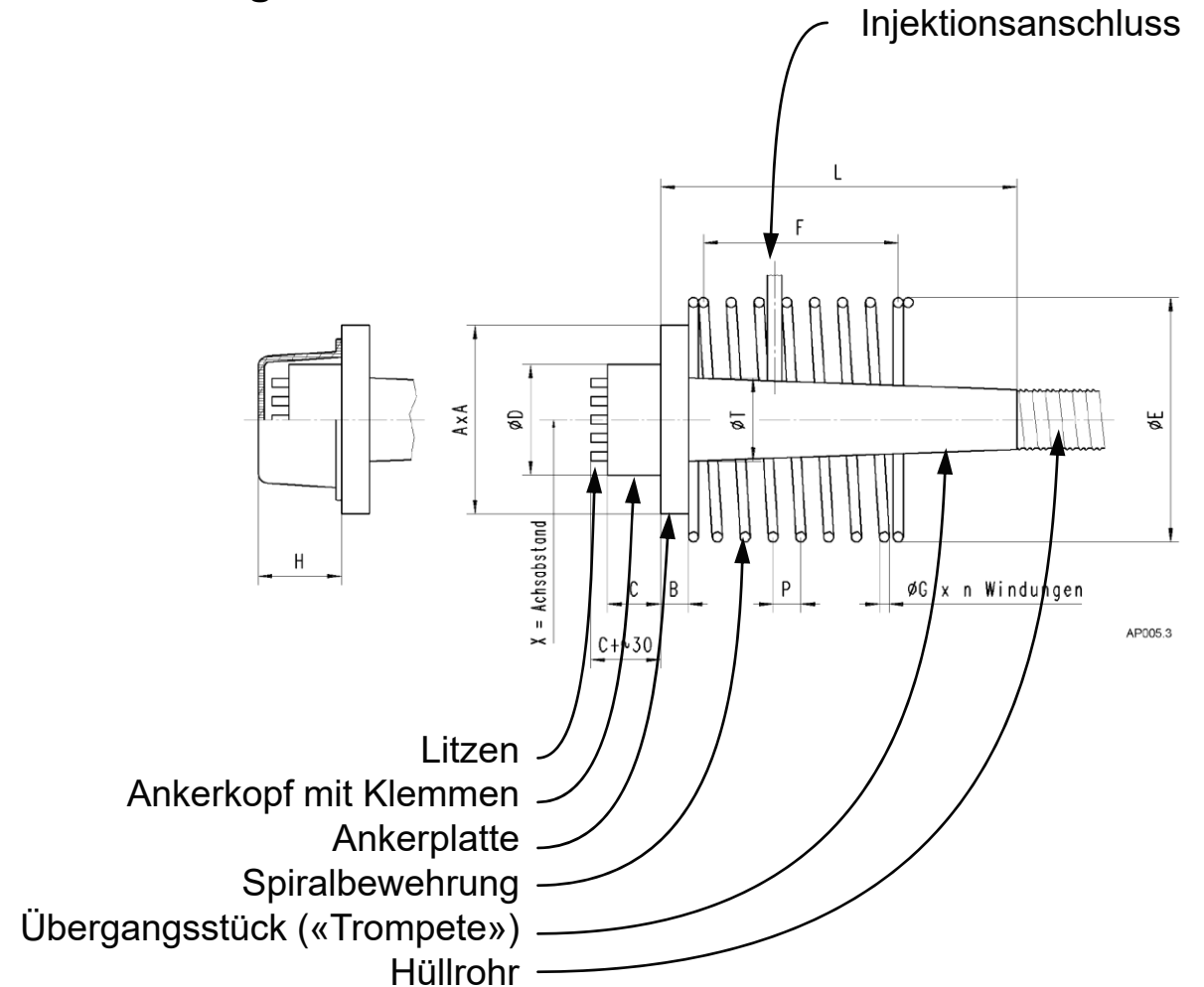
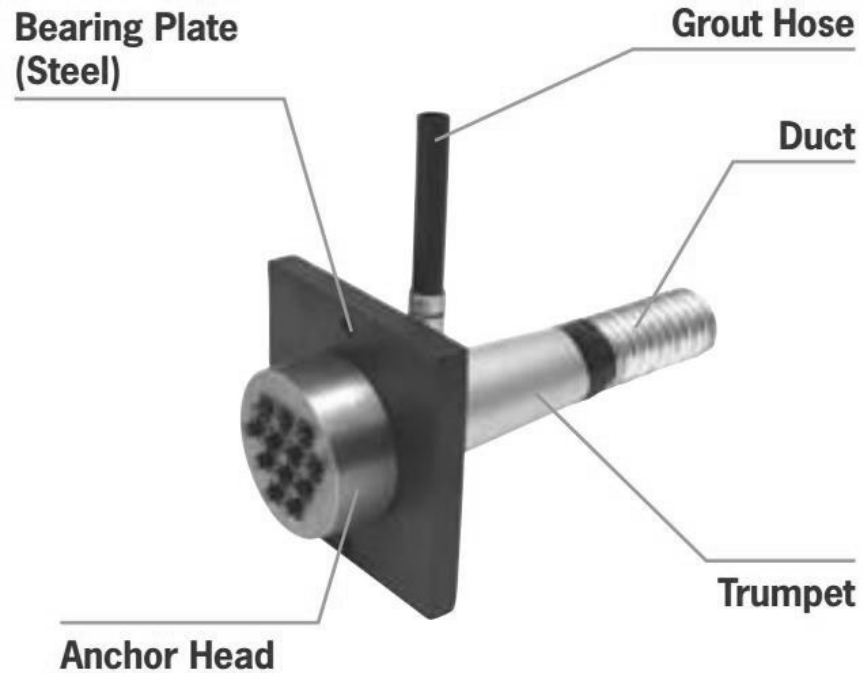

Bewegliche Verankerungen

Mehrflächenverankerung (Guss)
(VSL Typ EC)

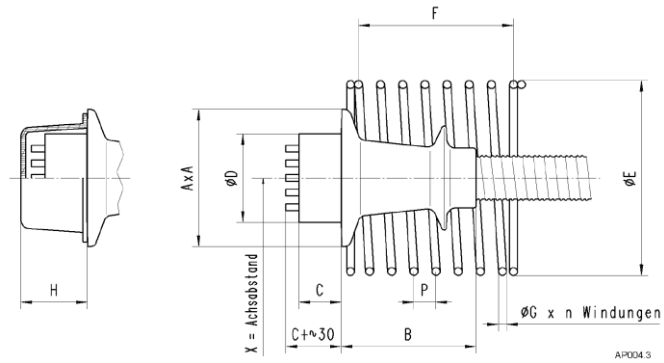

Verankerung mit Ankerplatte
(VSL Typ E)

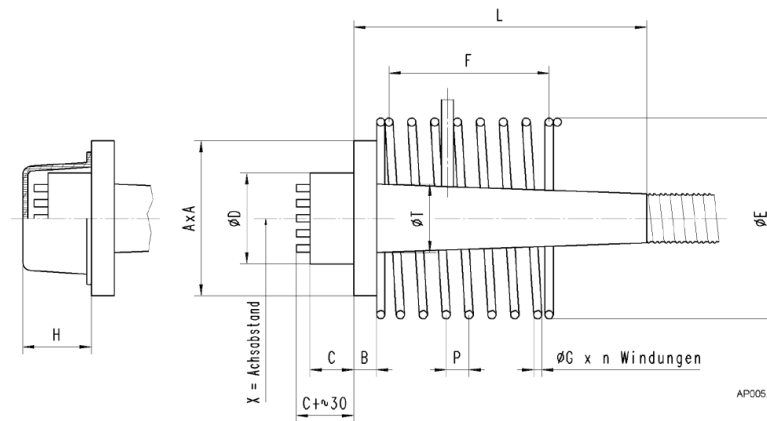

VSL Typ CC
(Composite)

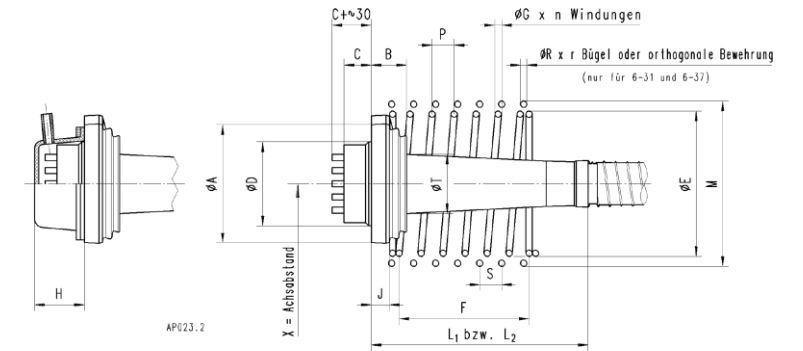

Vorspannung – Kupplungen

Kupplungen

Kupplung mit Abstützstelle (VSL Typ K)

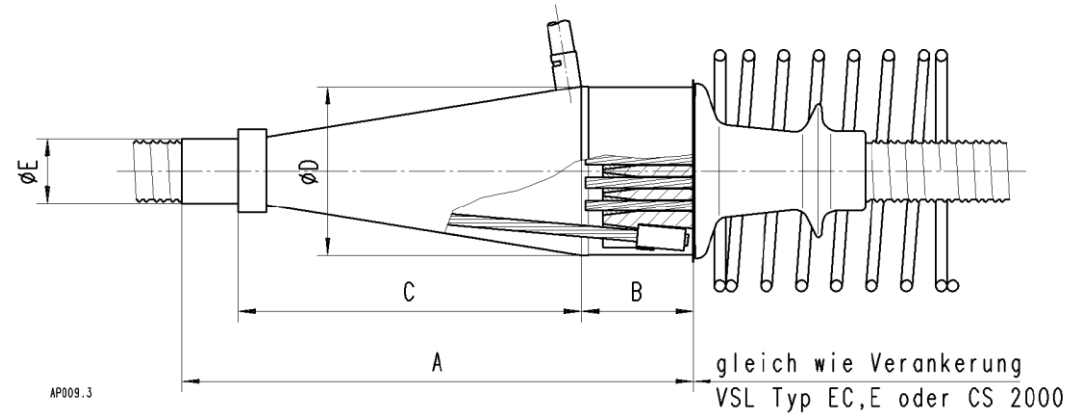
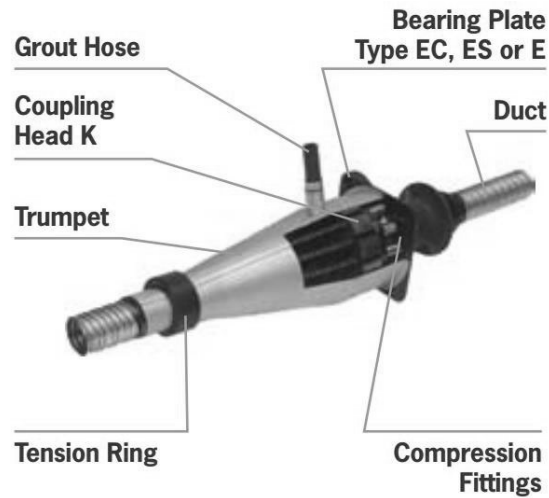

Gleitkupplung (selten) (VSL Typ V)

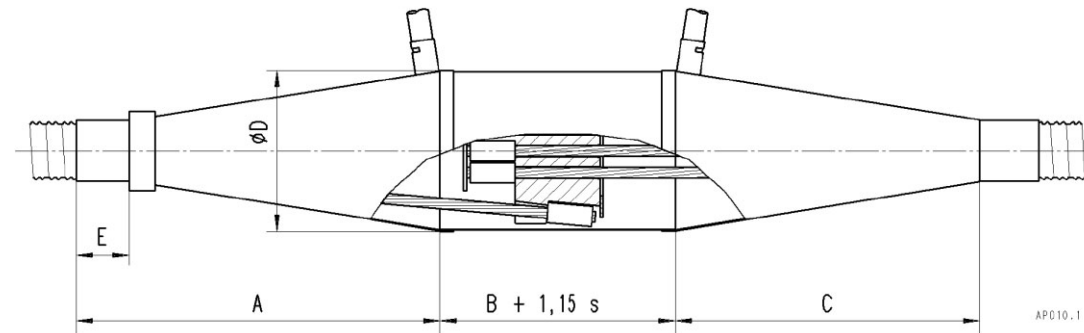



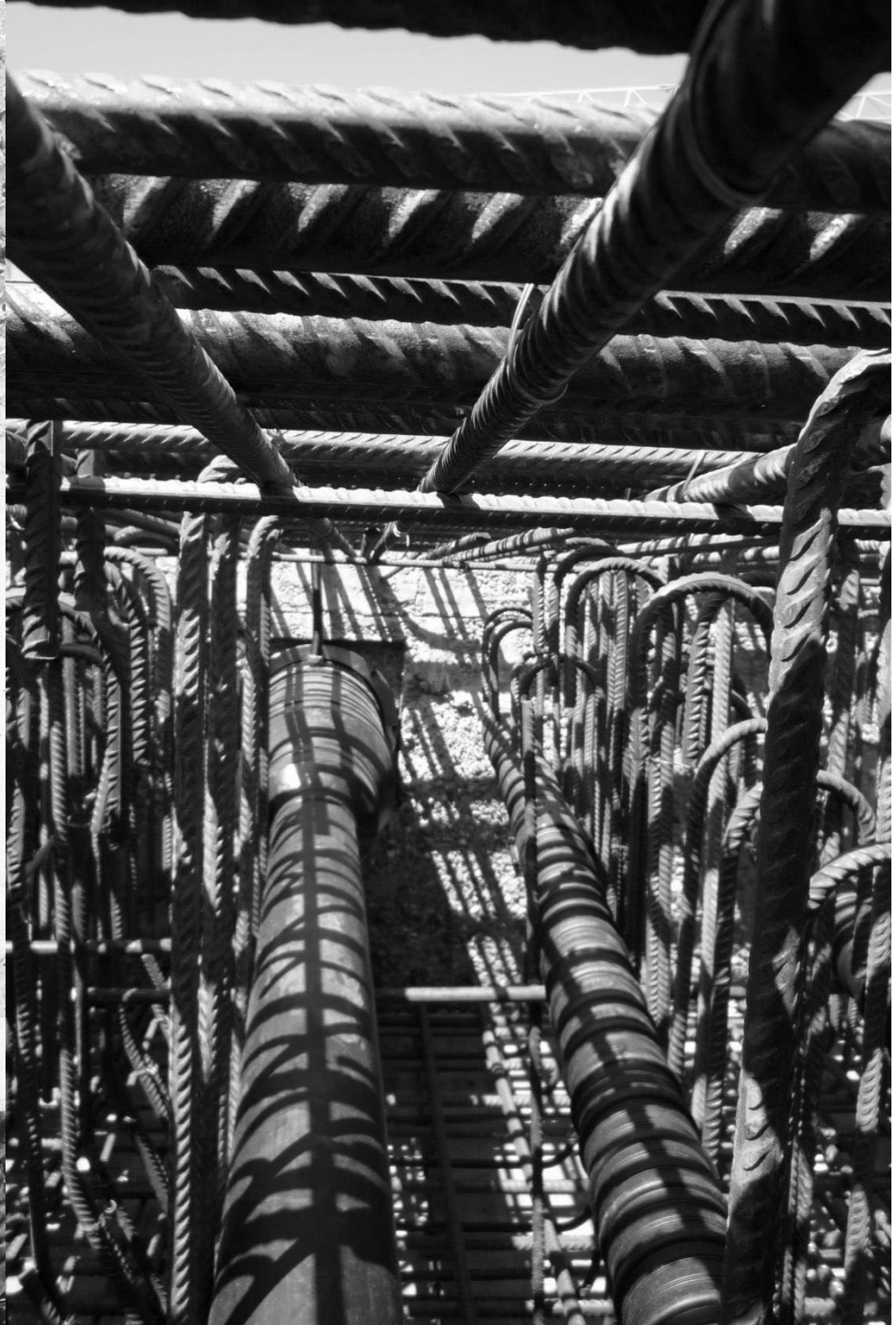
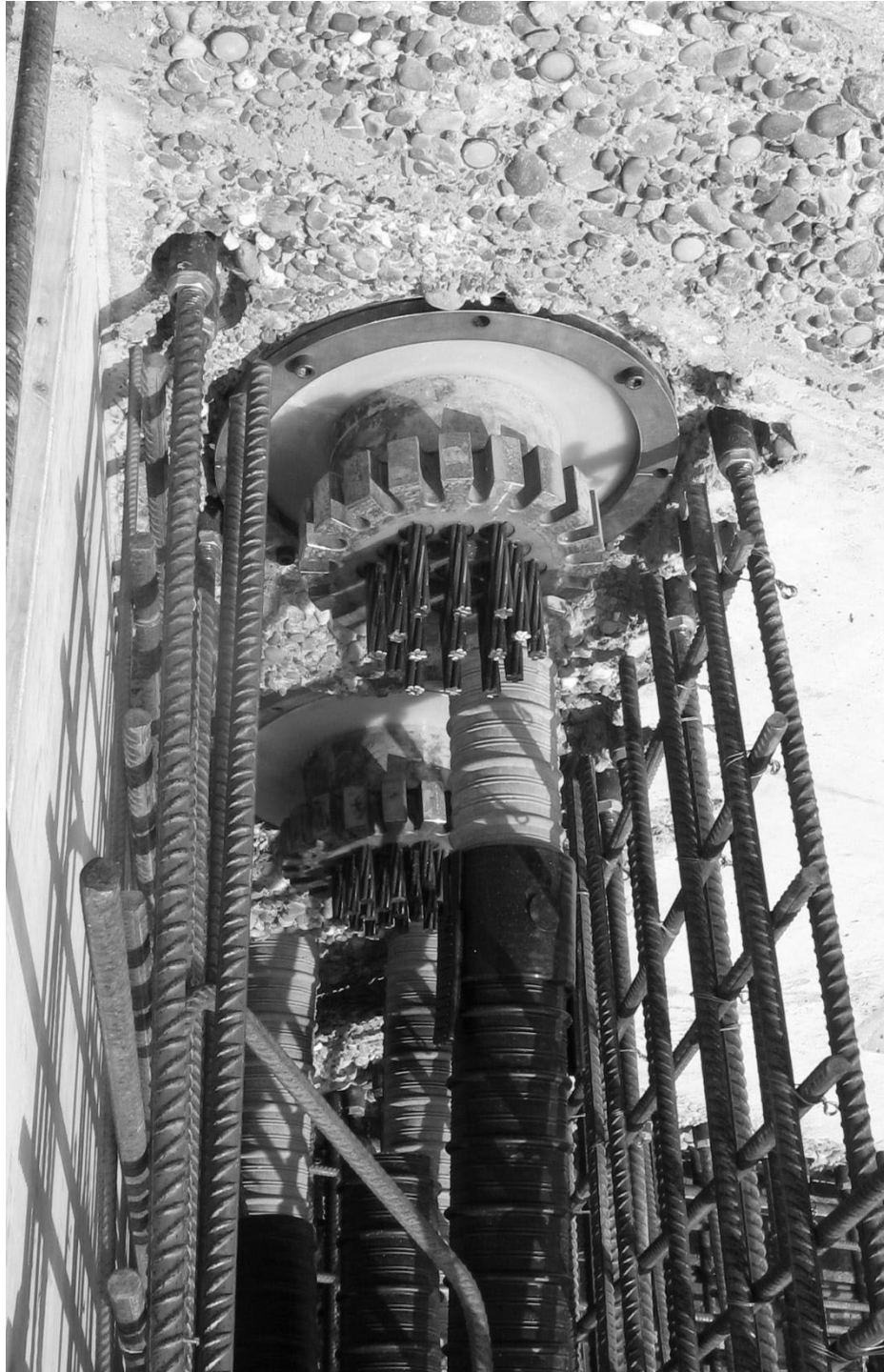

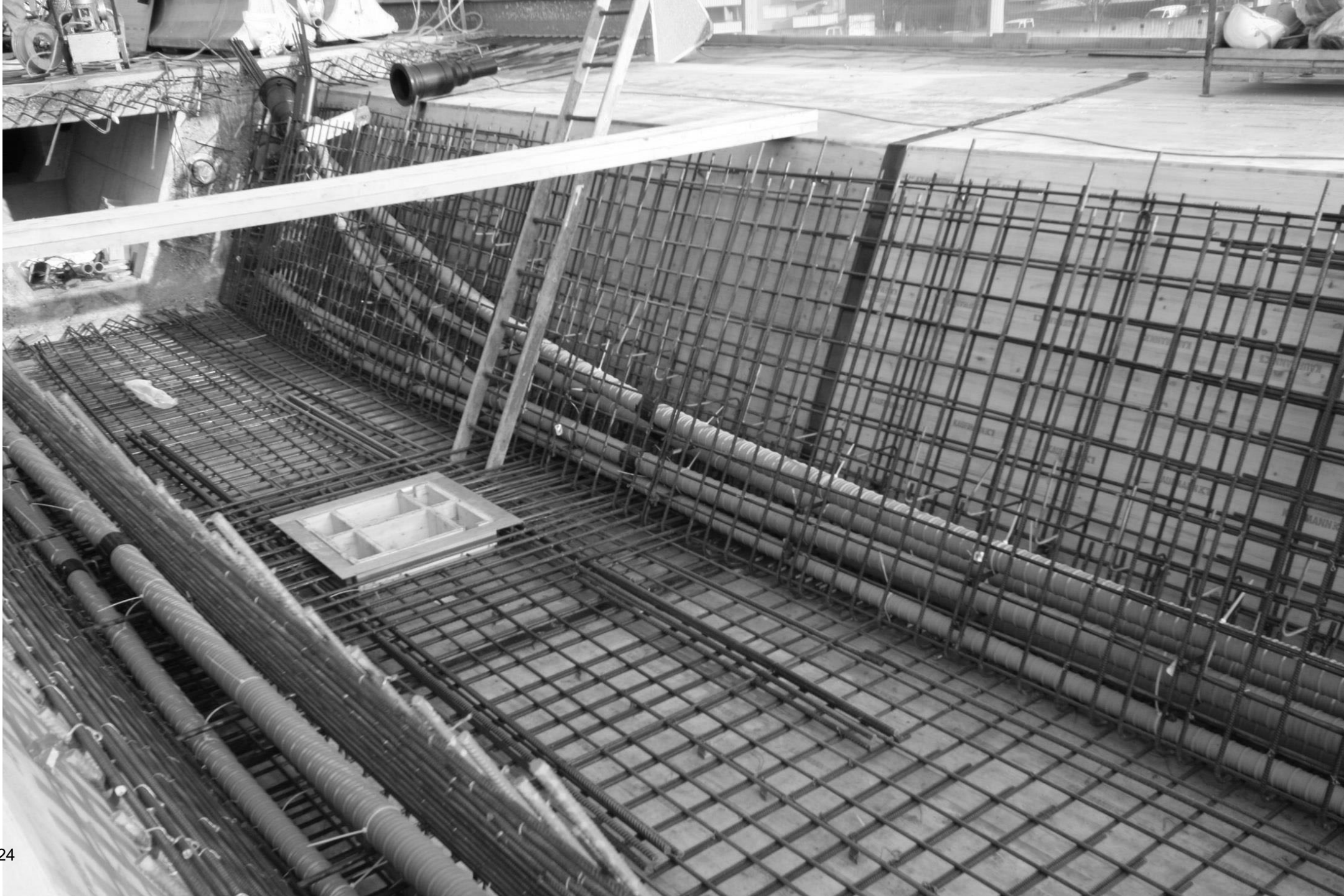







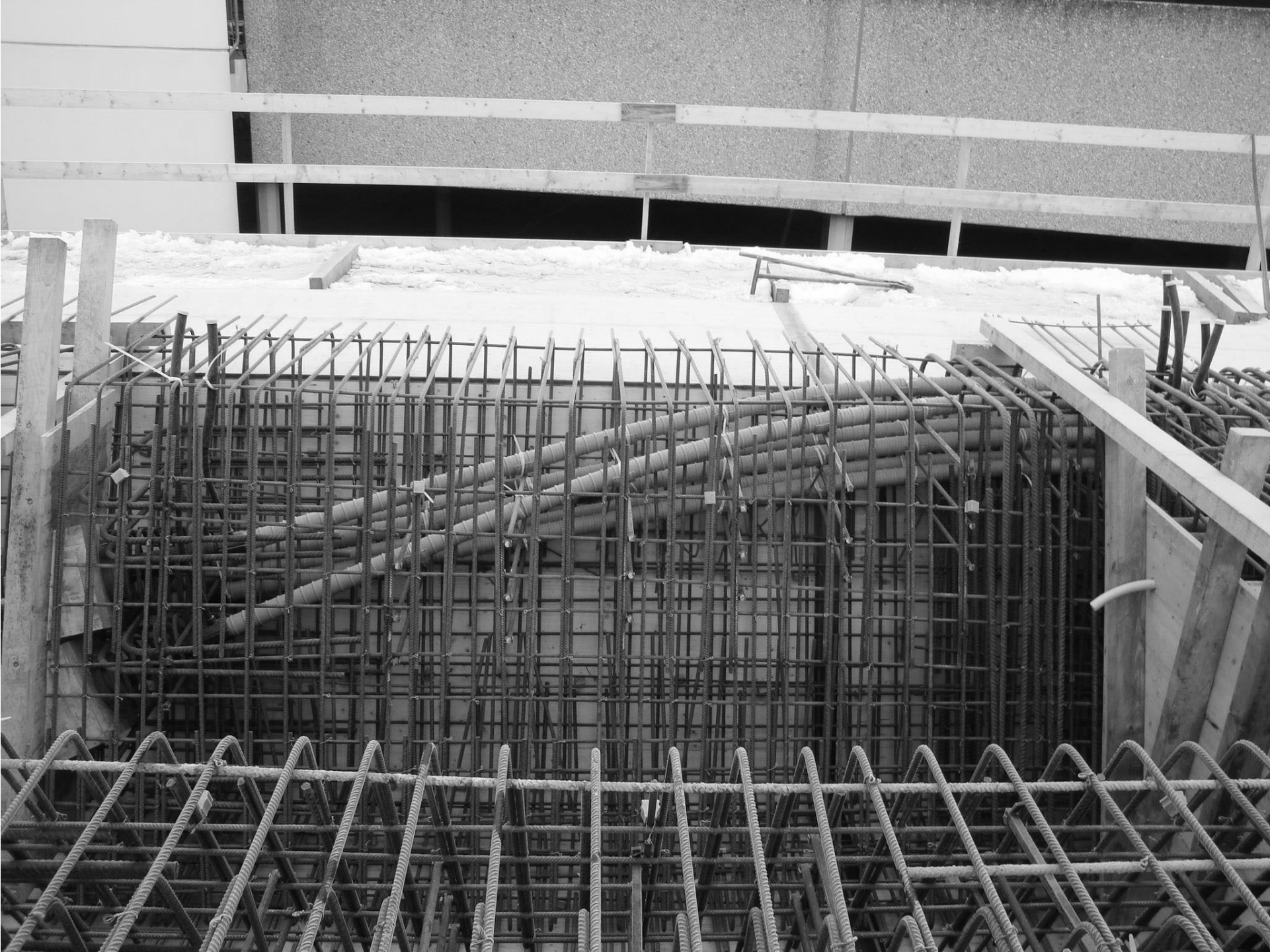









Umgang mit Spannstahl (SIA 262)

- Schutz gegen Korrosion, Witterungseinflüsse, mechanische Beschädigung, Verschmutzung
- Beim Einbau frei von Rost (Flugrost ok)
- Fristen zwischen Einbau, Spannen und Injizieren kurz halten, bei günstigen Bedingungen (keine Tausalzeiwirkung usw.) zulässig:
 - ≤ 12 Wo zwischen Herstellung der Spannglieder und Injizieren, wobei
 - ≤ 4 Wo in Schalung, vor Betonieren
 - ≤ 4 Wo in gespanntem Zustand
- Können diese Fristen nicht eingehalten werden oder herrschen ungünstige Bedingungen, sind temporäre Schutzmassnahmen zu planen:
 - Zugelassene Schutzemulsion oder Einblasen von trockener Luft, $RH < 50\%$











Aufbringen der Vorspannung

Nischenausbildung

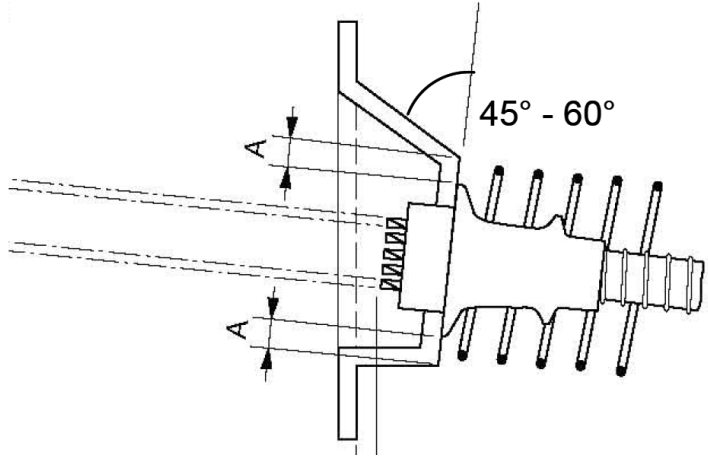

Platzbedarf
Spannpresse

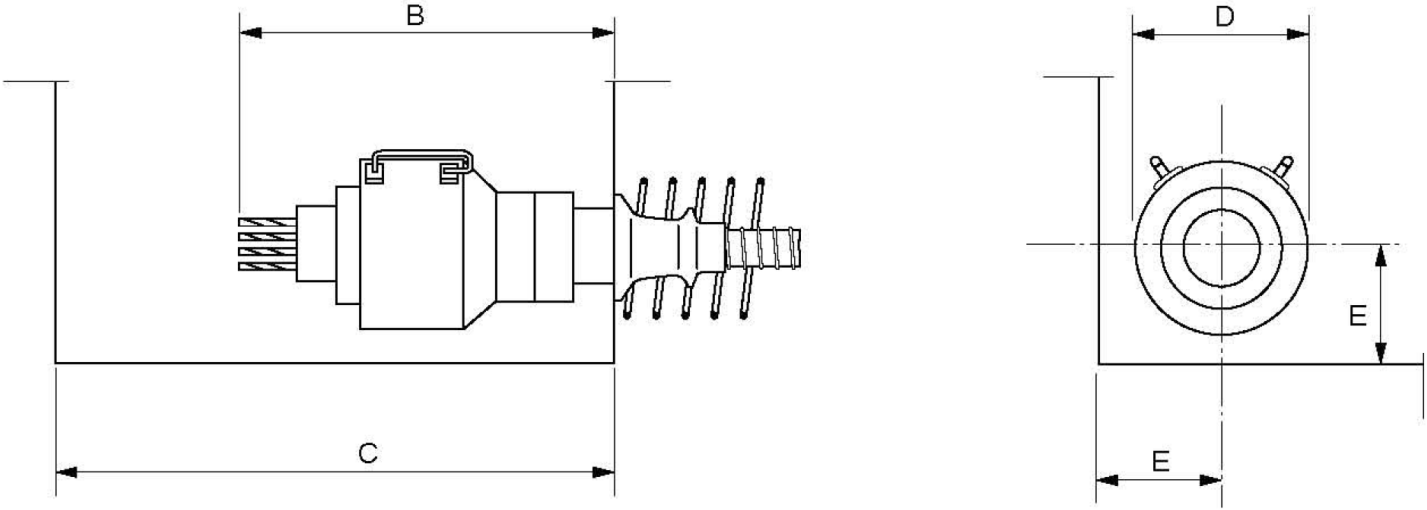

Aufbringen der Vorspannung

1.

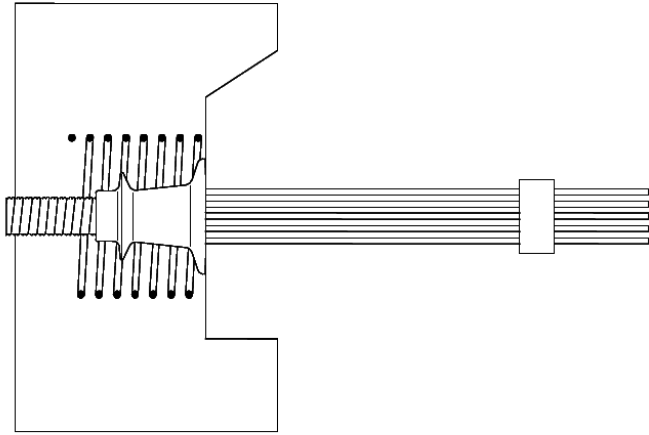

Setzen der Ankerbüchse und der Klemmen

3.

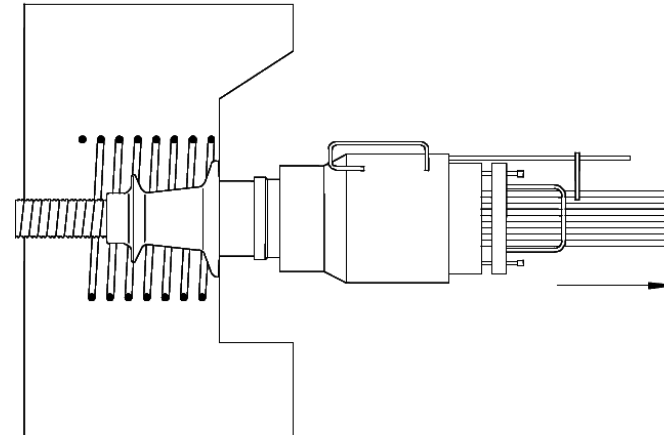

Spannen

2.

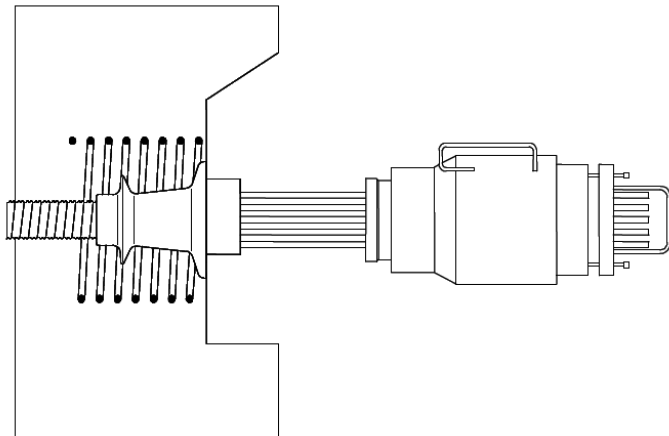

Ansetzen der Spannpresse

4.

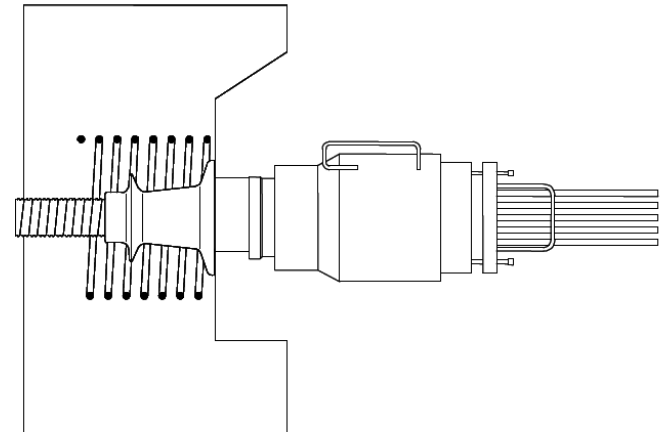

Verkeilen

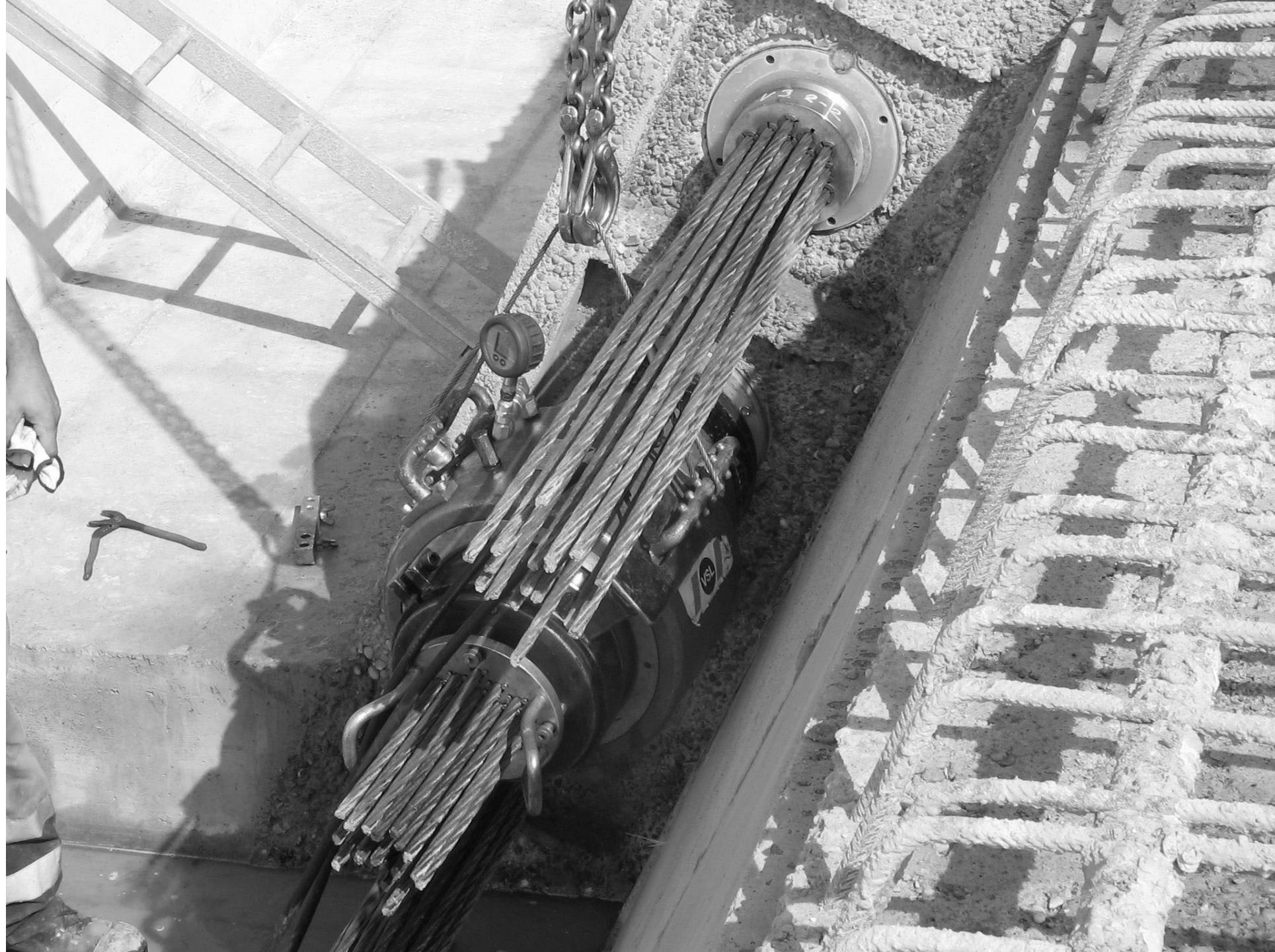



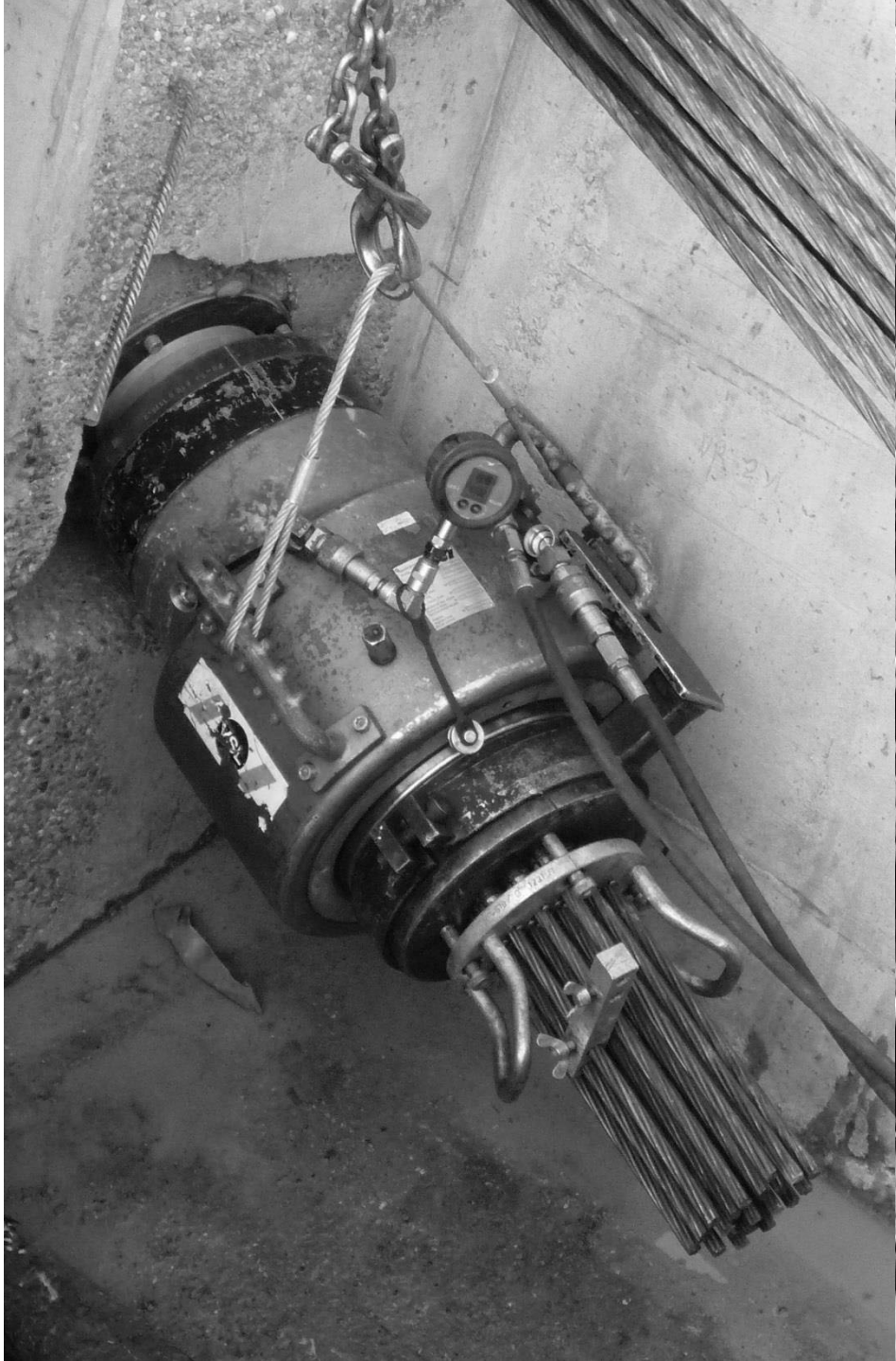



Injektion der Hüllrohre (SIA 262 / SN EN 446)

Injektionsvorgang (sorgfältig zu planen, keine Improvisation auf Baustelle!)

- Kontrolle, ob sämtliche Hüllrohre durchgehend offen sind
- Temperatur im Hüllrohr während der ersten $h \geq +5^\circ\text{C}$
- Aufbereitung des Füllguts mit kontinuierlich arbeitenden Misch- und Fördergeräten
- Verbrauch an Füllgut im Sinne einer Grobkontrolle überwachen
- Injektion von unten, Verfüllung bei allen Entlüftungsstutzen prüfen (bis zum Austritt qualitativ guten Füllguts, anschliessend verschliessen und Druck auf ≥ 1 bar erhöhen)
- Gute Erfahrungen (vor allem in USA) mit Vakuuminjektion, in CH wenig bekannt

Injektionsprotokoll / Prüfbericht

- Alle wichtigen Beobachtungen während der Injektion und Kennwerte des Füllguts
- Am Tag nach der Injektion kontrollieren, dass in den Entlüftungsstutzen keine Wasserausscheidung vorliegt (wenn doch, sind Massnahmen erforderlich)

Produktionskontrolle (SN EN 445...447)

- Siebprüfung (keine Mörtelklumpen in Sieb mit Maschenweite ≤ 2 mm)
- Fliessvermögen mit Trichterverfahren ($1\text{l in} \leq 25\text{s}$, $t=0/30$ min) oder über Ausbreitmass
- Wasserabsonderung, Volumenstabilität und Filterwirkung der Litzen mit Absetztest:
 - im Schrägrrohr: 2 Rohre $\varnothing = 80$ mm, $l = 5$ m, $\alpha = 30^\circ$, 12 Litzen (nur Erstprüfung)
 - im Vertikalrohr: Rohr $\varnothing = 60\dots 80$ mm, $l = 1$ m, 1 Litze (1 oder 3 Prüfungen auf Baustelle)
(NB: Prüfung mit Dose $h = 152$ mm ohne Litze ist nicht mehr aktuell)
- Druckfestigkeit und Festkörperdichte

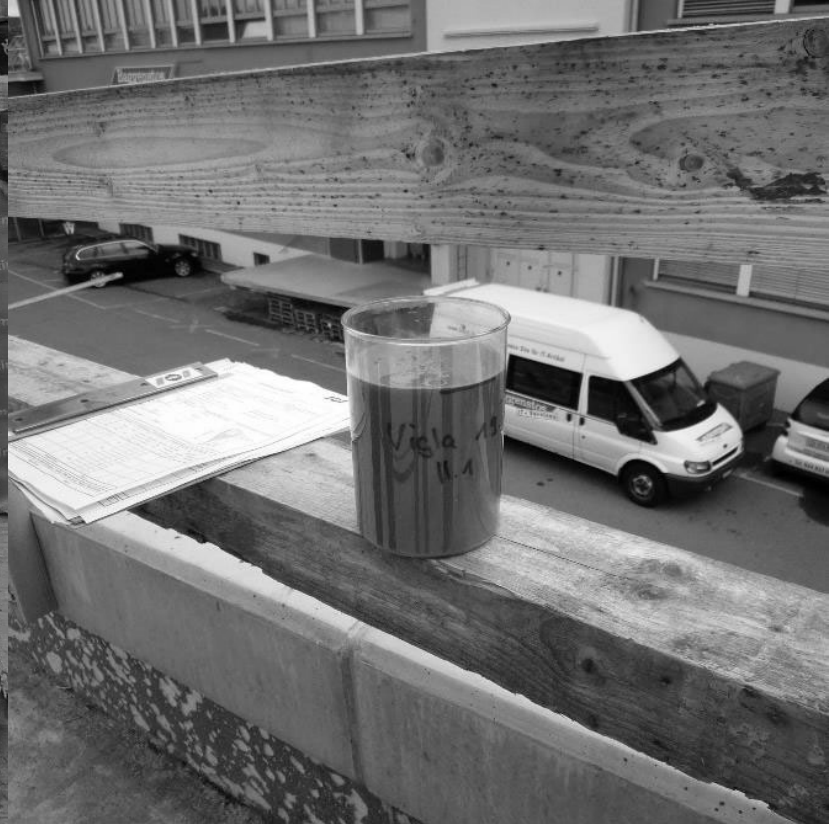







Elektrisch isolierte Spannglieder

Spanngliedkategorie a: Stahlhüllrohr

- Keine Ermüdungsbeanspruchung
- Nur für Expositionsklassen \leq XC3, XF1
- Nur für Bauwerksklasse \leq II

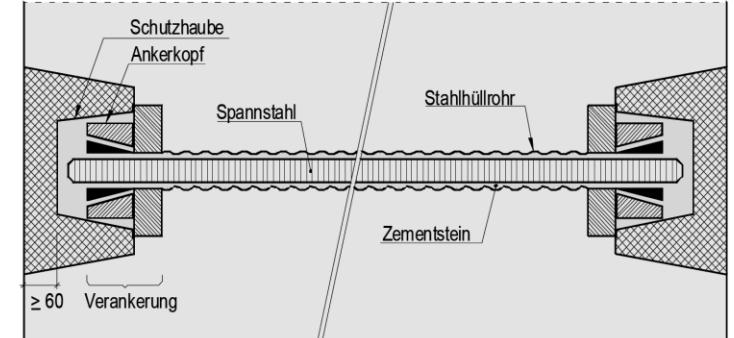

Spanngliedkategorie b: Kunststoffhüllrohr

- Bei Ermüdungsbeanspruchung (bei ASTRA nur für Quervorspannung Brückenplatten)
- Für Expositionsklassen \geq XC4, XF2, XD1

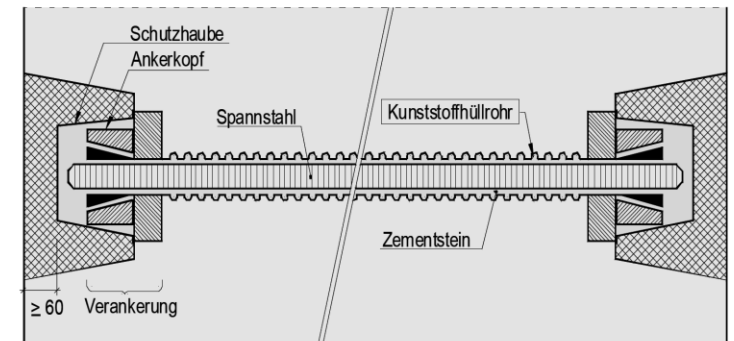

Spanngliedkategorie c: Kunststoffhüllrohr, Spannglied elektrisch isoliert

- Bei Ermüdungsbeanspruchung (immer bei SBB)
- Bei Streustromgefährdung (u.a. Bahnbereich)
- Überprüfung mit Impedanzmessung (= elektrische Widerstandsmessung zwischen Spannstahl und Bewehrung mit Wechselstrom)

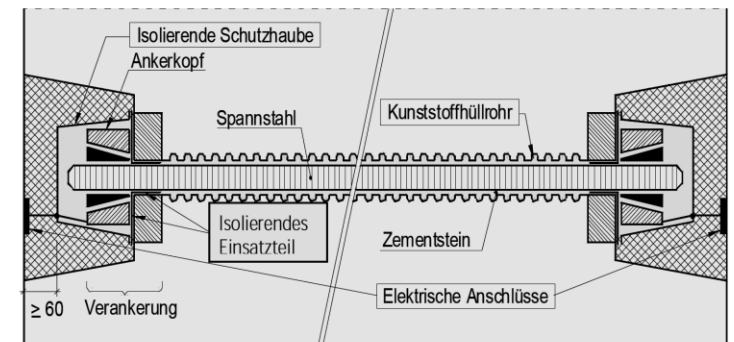







Kabelvorspannung im Brückenbau

Beispiele / Fotos:

Viadukt Glattzentrum (2009)

Innbrücke Vulpera (2010)

Versamertobelbrücke (2012)

Steinbachviadukt (2014)

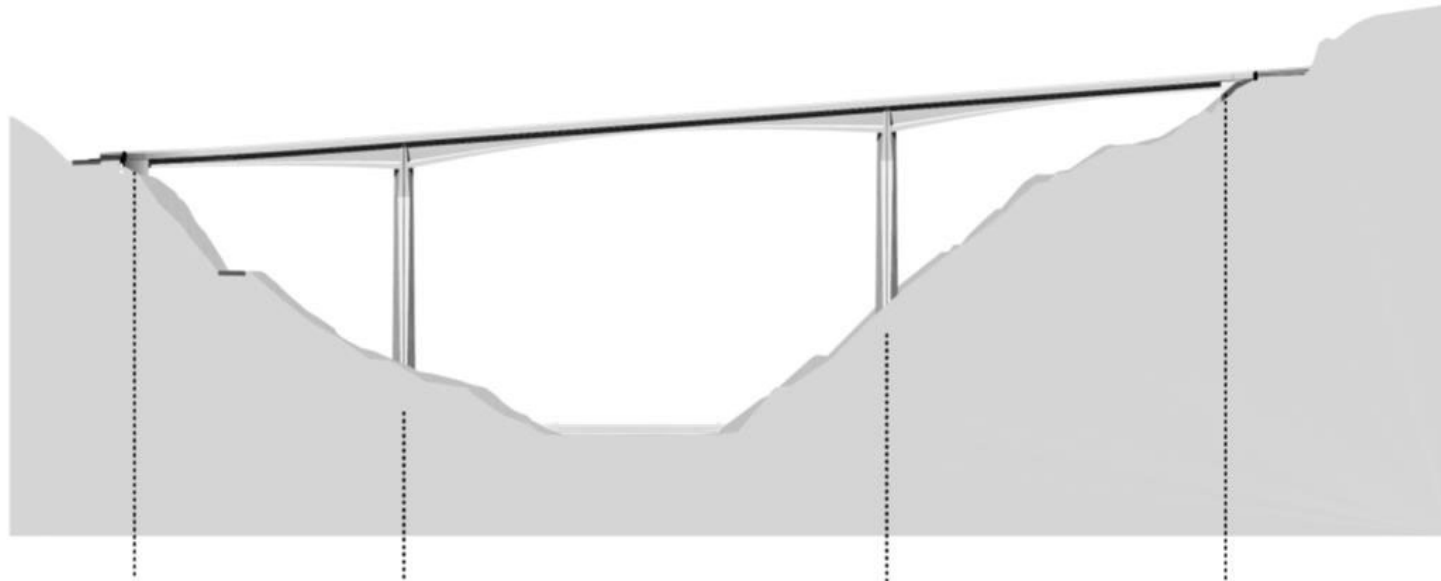

Kragarmvorspannung : 6 - 7: 1301 kN / 6 - 12: 2230 kN

Schema

aussen 12Ø0.6"
innen 7Ø0.6"

innen 7Ø0.6"
aussen 12Ø0.6"

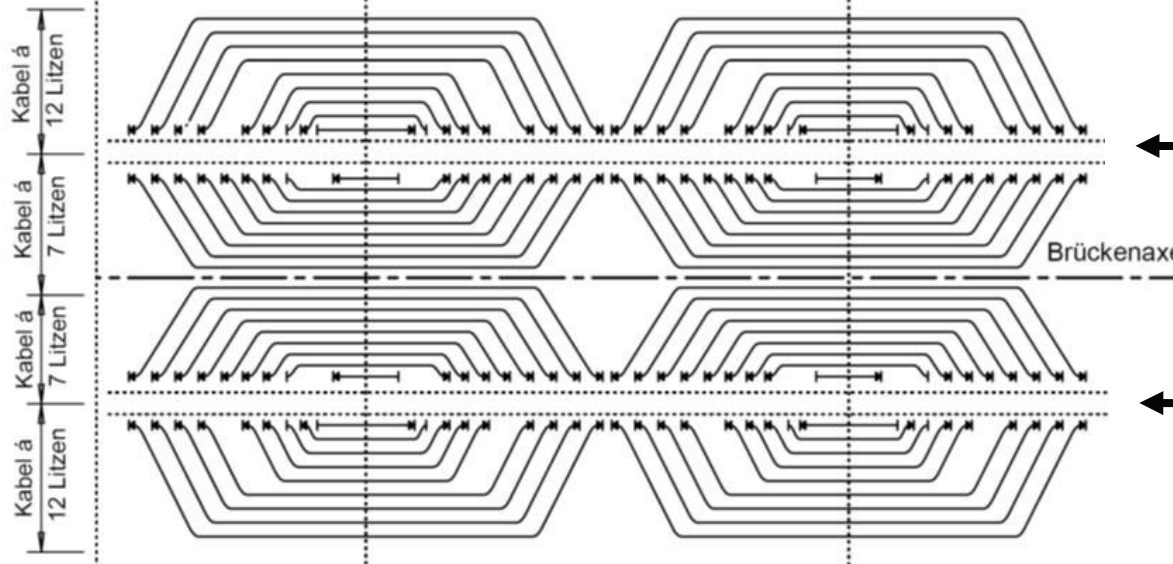

← Steg

← Steg

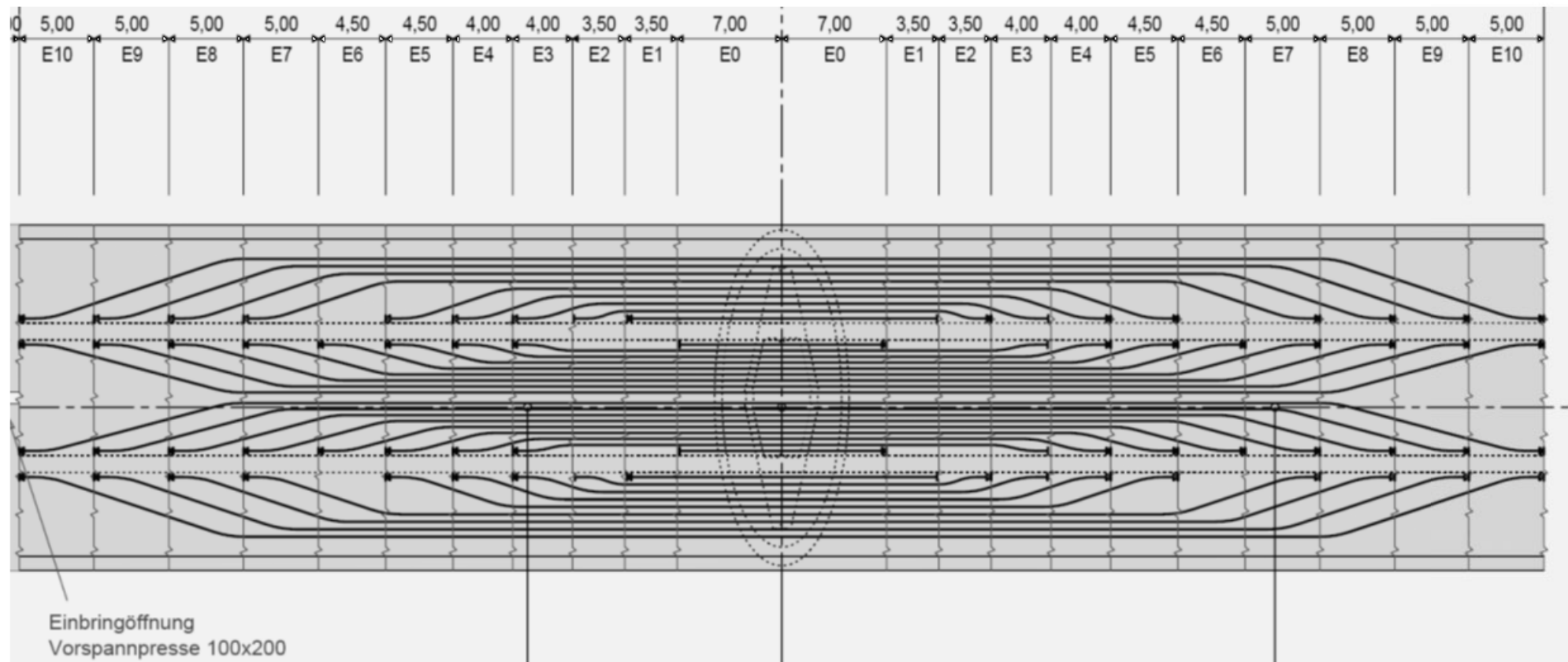
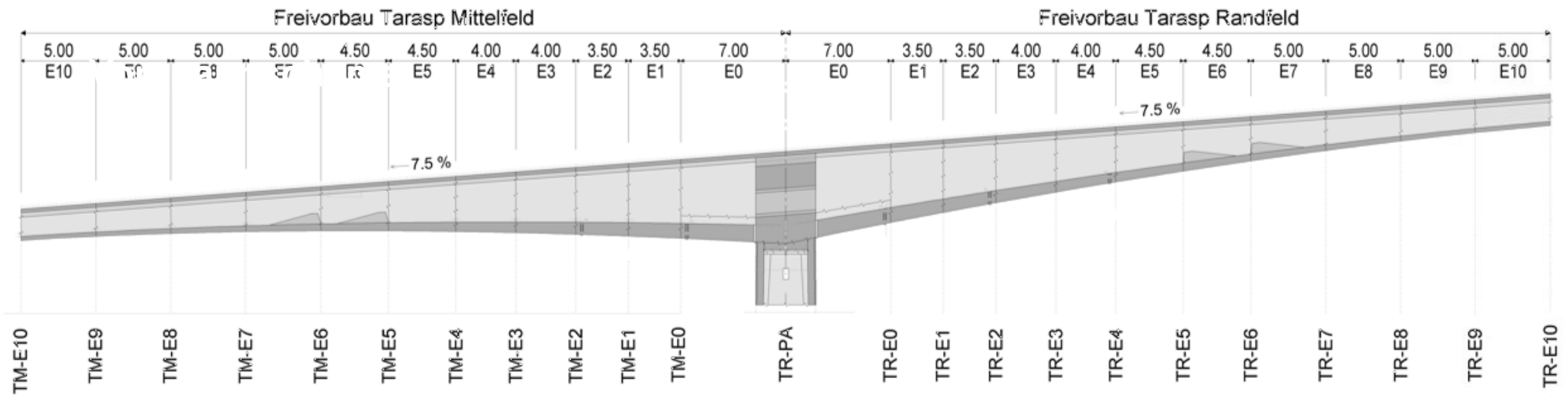

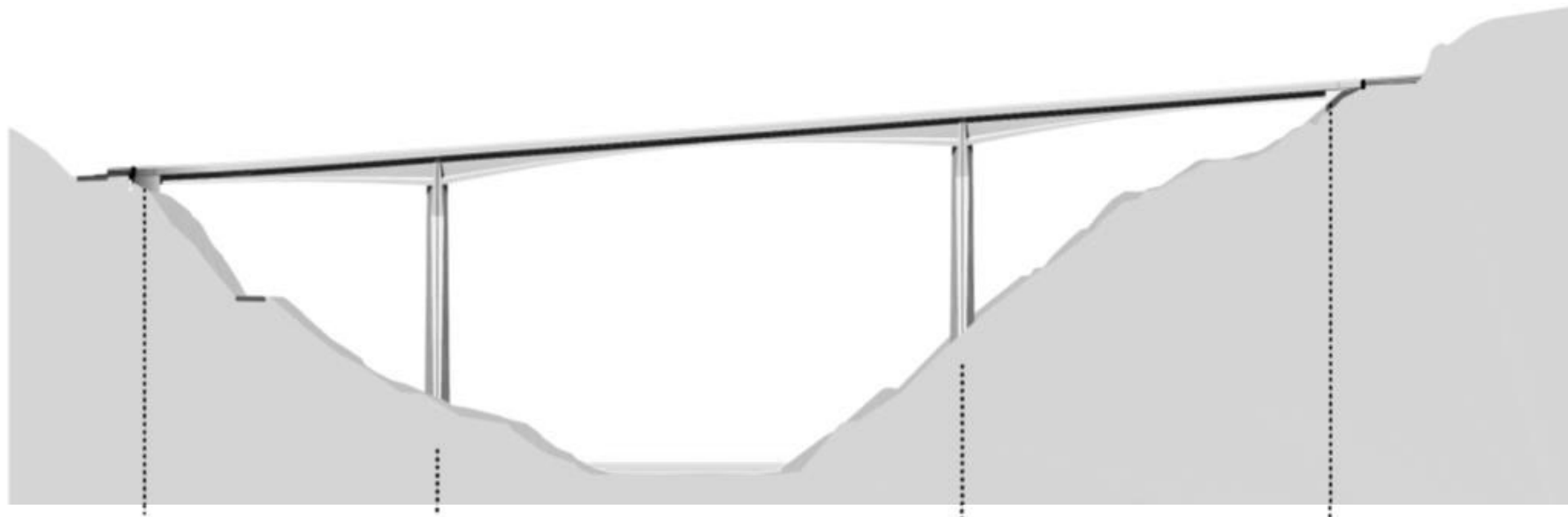

Feldvorspannung : je 4 x 6-19: 3531 kN



Kontinuitätsvorspannung : je 2 x 6-19: 3531 kN

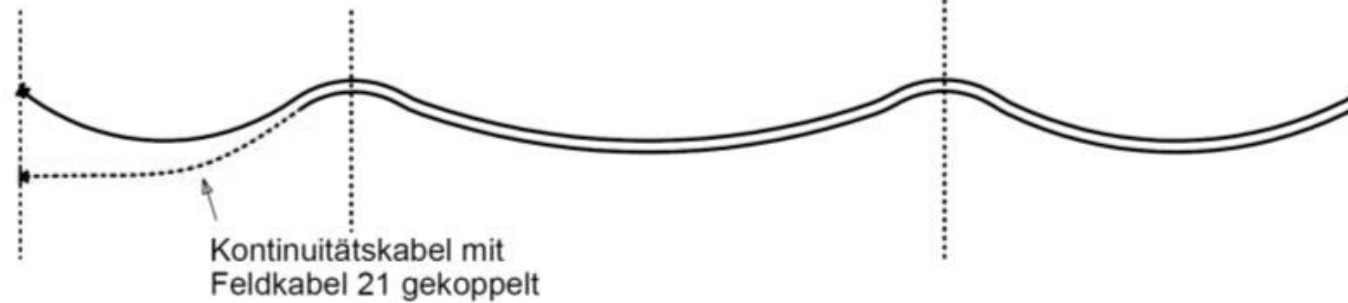

Bauausführung

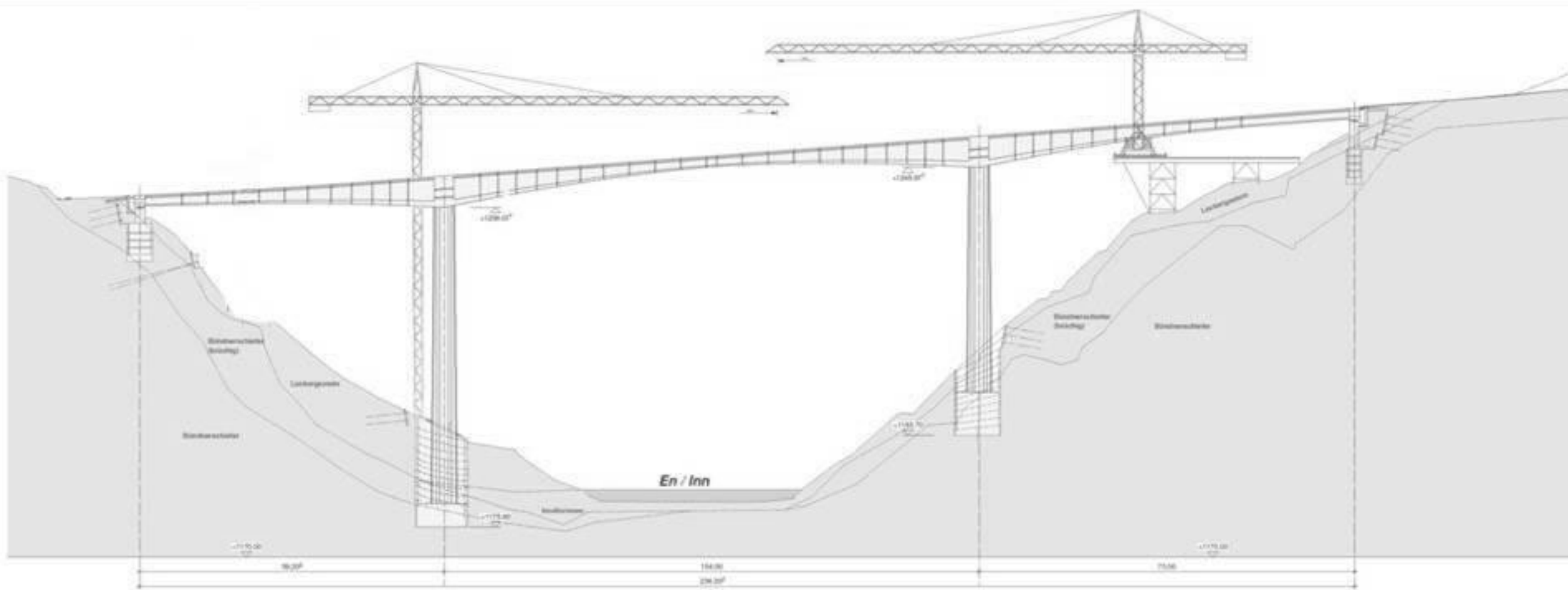



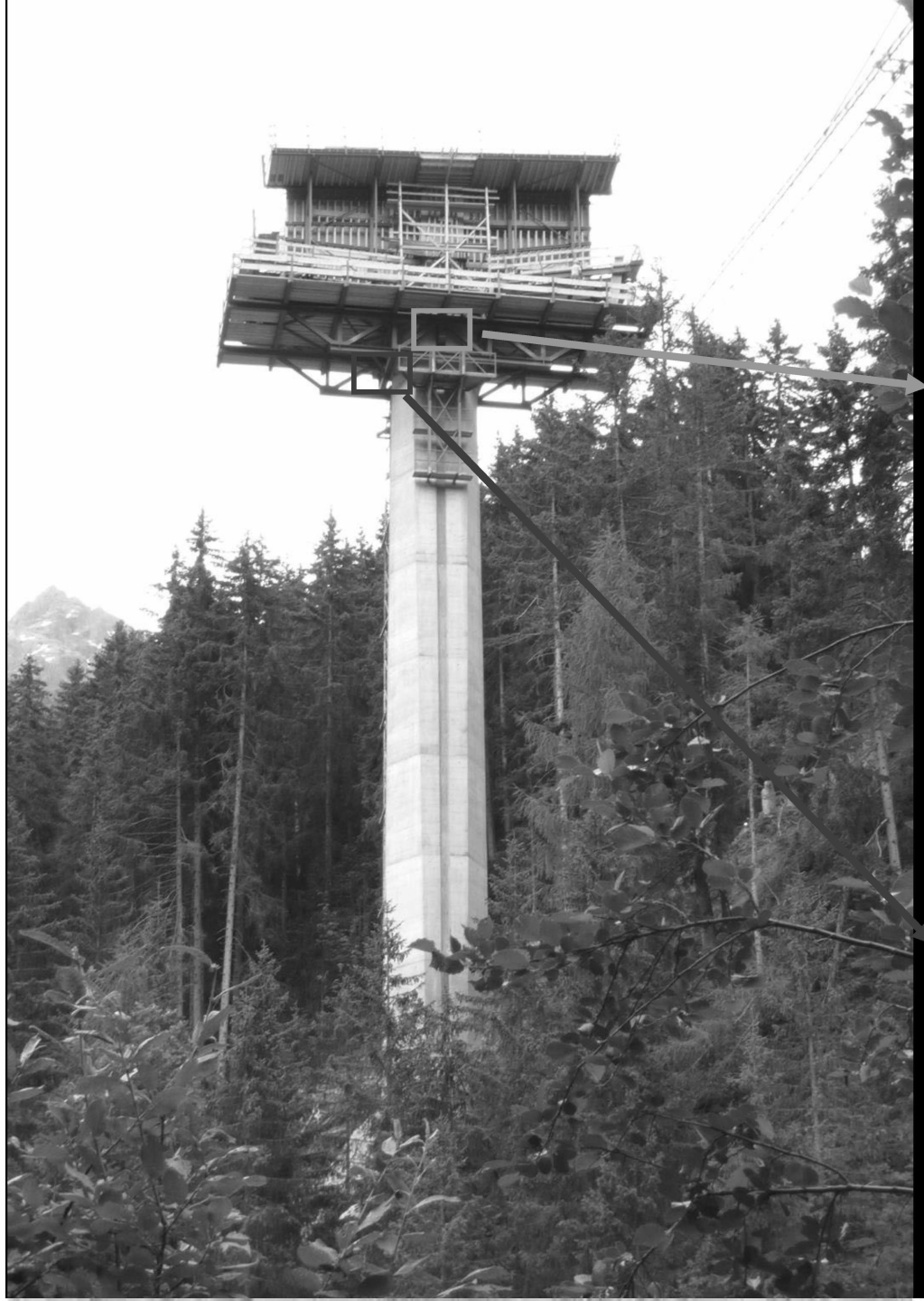



ERNI
LAZZARINI

**ZUBLIN
MURER**

BEZZOLADENOTH

**FOFFA +
CONRAD SA**















Punt d'En Vulpera / Tarasp
2007 - 2010



Bauherrschaft und Gesamtleitung
Tiefbauamt Graubünden
Uffiz da construcziun bassa dal Grischun
Ufficio tecnico dei Grigioni

Projektierung
dsp
ARGE Punt d'En Vulpera
STRABAG ERNI LAZZARINI

Bauführung
Tiefbauamt Graubünden
Uffiz da construcziun bassa dal Grischun
Ufficio tecnico dei Grigioni

Condotta

















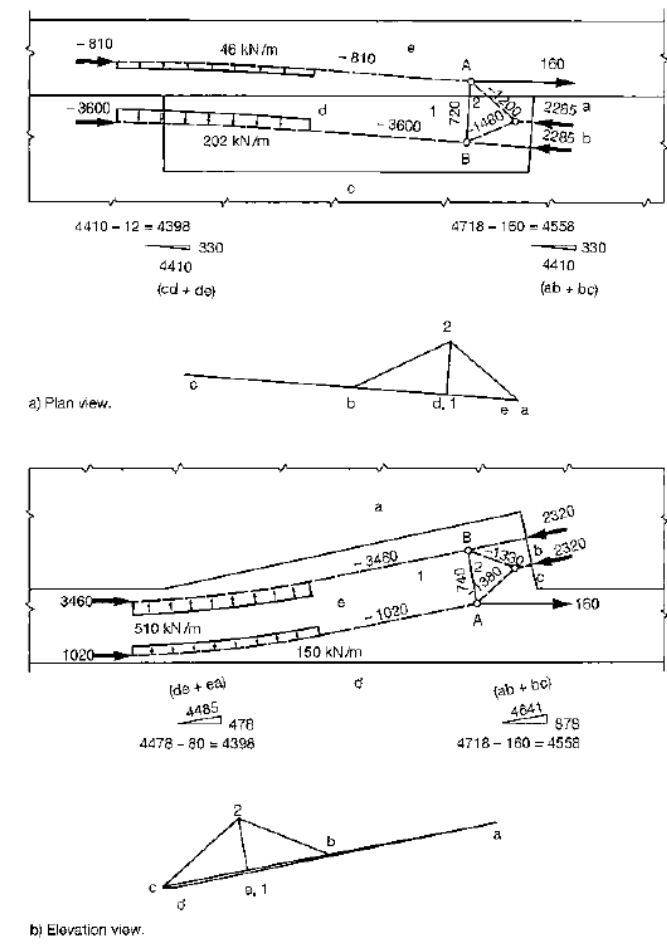
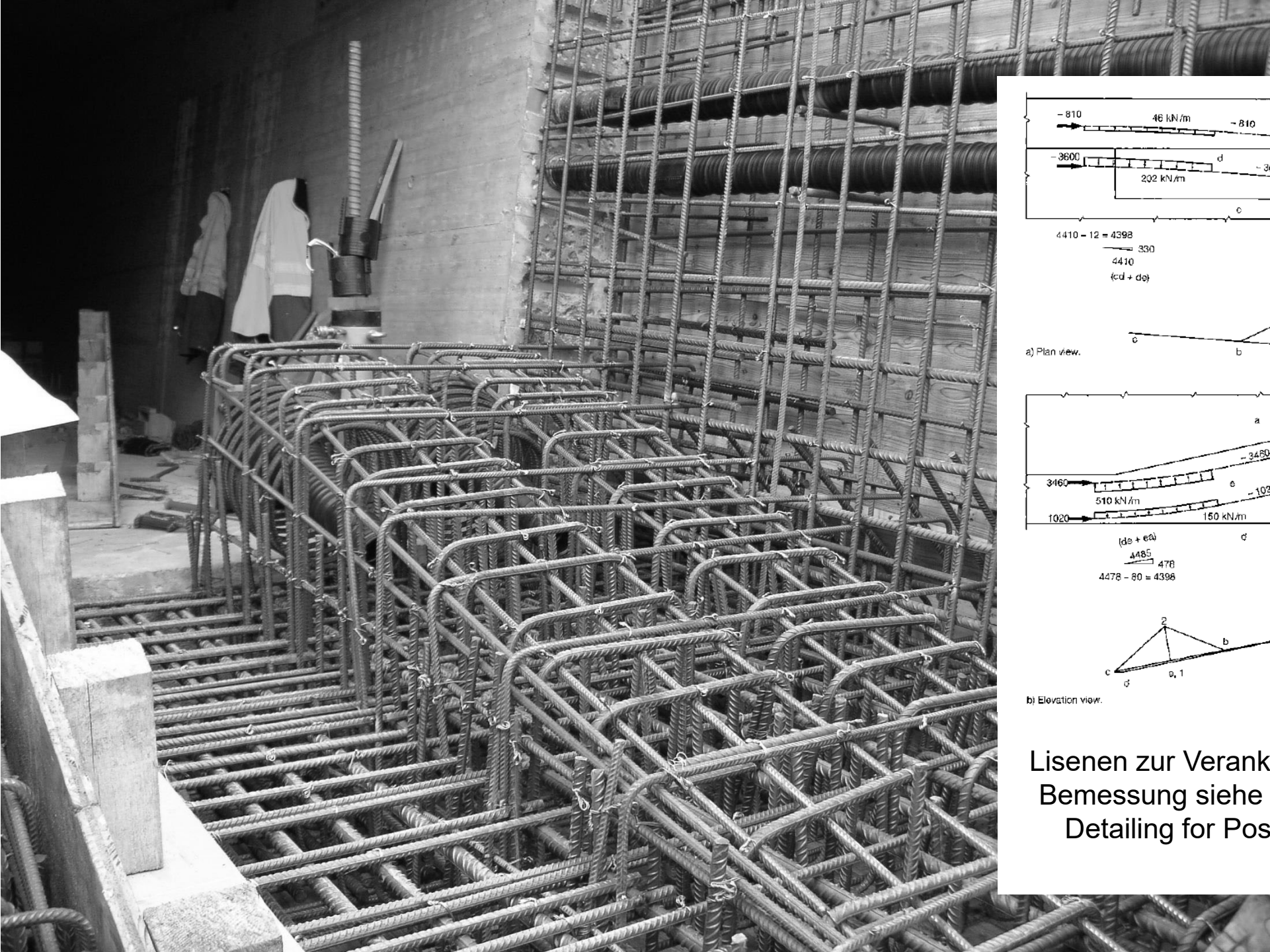

Lisenen zur Verankerung im Feld
 Bemessung siehe z. Bsp. VSL,
 Detailing for Posttensioning



Einschiessen einzelner Litzen
(Normalfall)



Einschiessen einzelner Litzen
(Normalfall)













Kontinuitätskabel L = 240 m
Sonderlösung (einziehen
ganzes Bündel mit Winde)



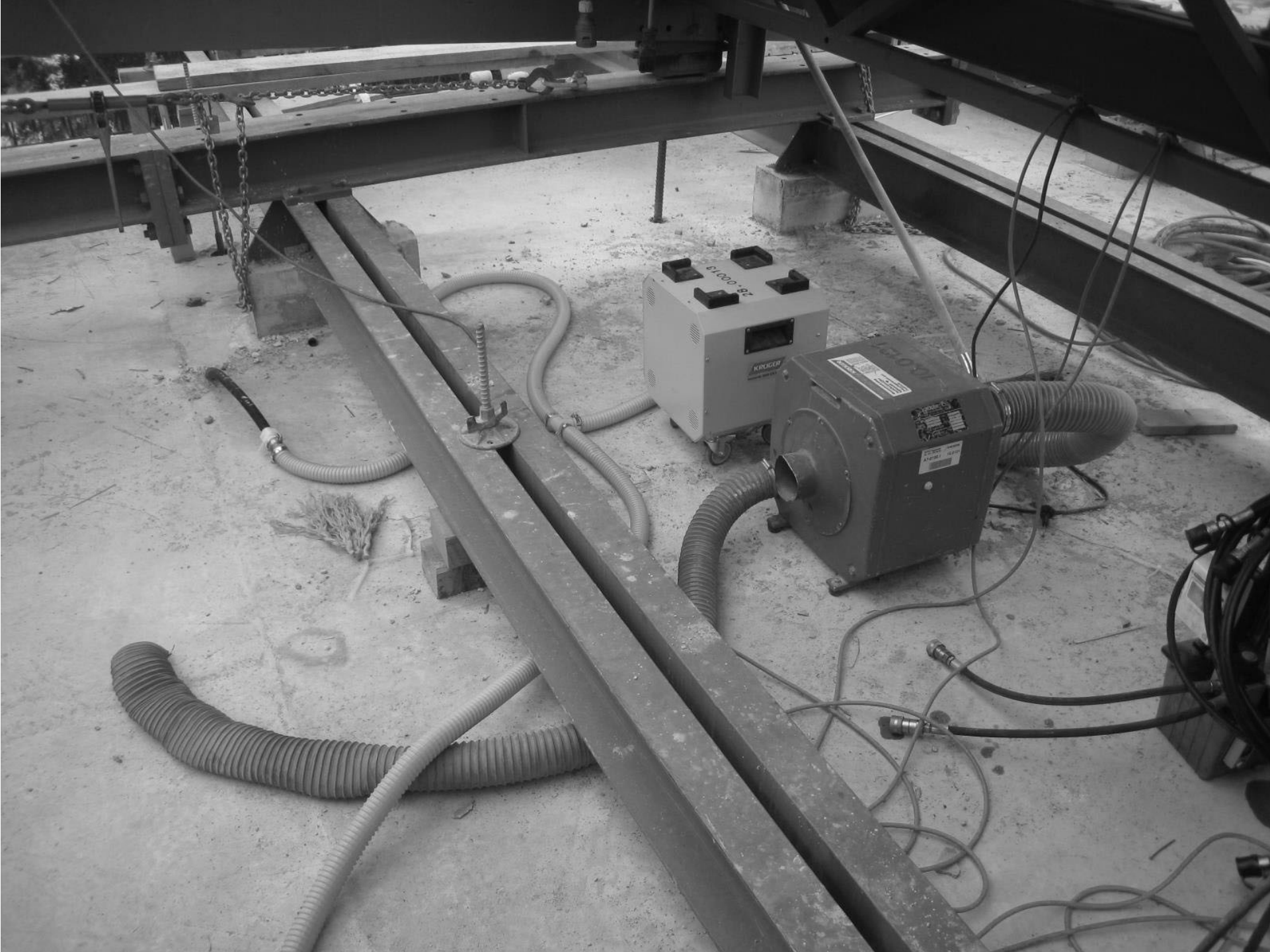

Kabelvorspannung im Brückenbau

Beispiele / Fotos:

Viadukt Glattzentrum (2009)

Innbrücke Vulpera (2010)

Versamertobelbrücke (2012)

Steinbachviadukt (2014)



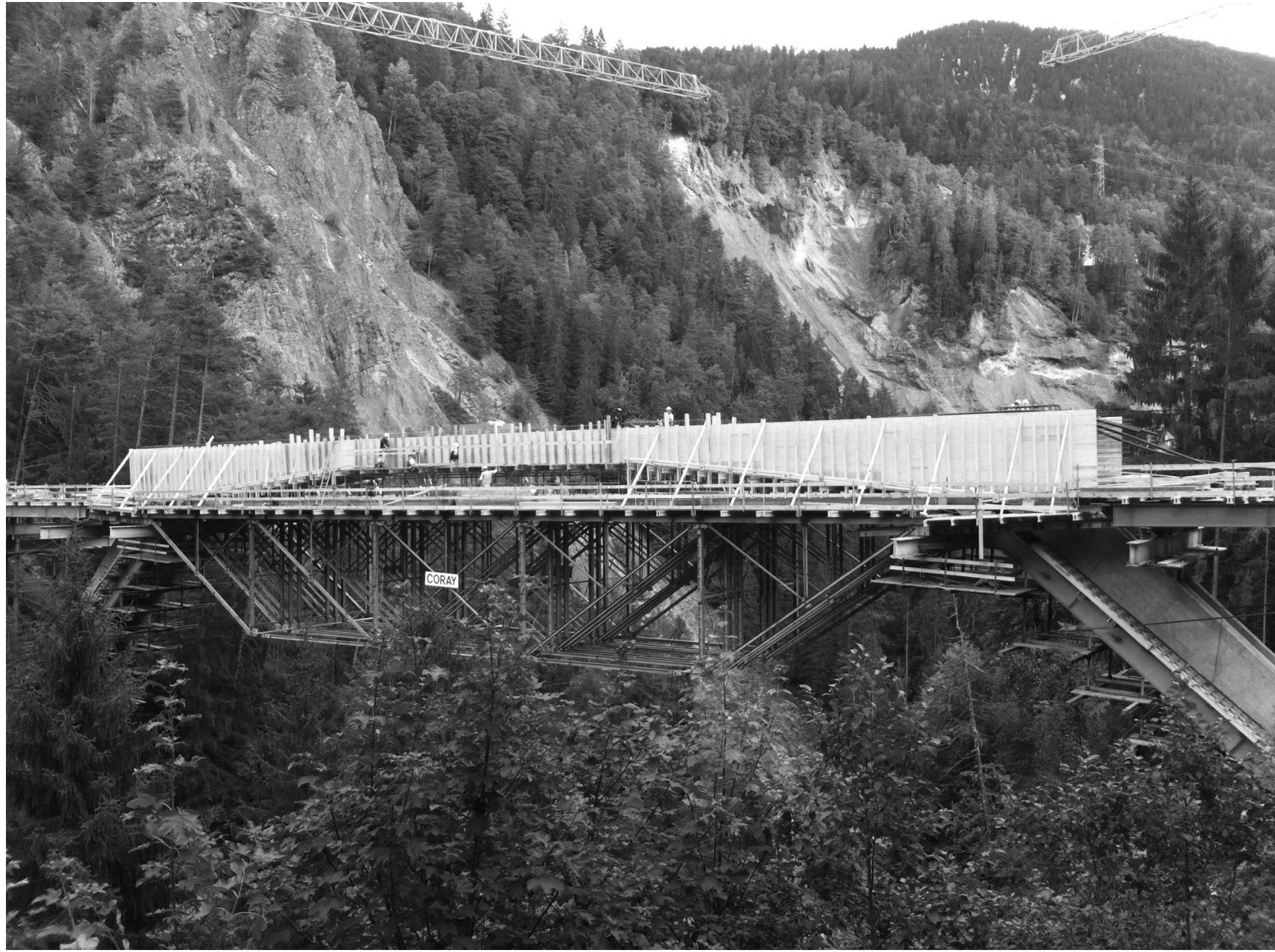















Kabelvorspannung im Brückenbau

Beispiele / Fotos:

Viadukt Glattzentrum (2009)

Innbrücke Vulpera (2010)

Versamertobelbrücke (2012)

Steinbachviadukt (2014)









Massgebend für Bauprogramm (Takt 3 Wochen):

- Vorspannung (Betonalter, Druckfestigkeit)
- Injektion (Temperatur, keine Bewegungen beim Erhärten)

Mi	Betonieren
Mo	Vorspannung 30% (> 3d)
Di-Do	Ausschalen Mittelelemente
Fr	Vorspannung 100% (9d, $\geq 0.90 \cdot f_{ck}$) Vorfahren Kran nach Vorspannung Injektion nach Vorfahren
Mo/Di	Ausbau Schalboden Vorschieben Lehrgerüst
Mi	Montage Schalungselemente Vermessungskontrolle
Do/Fr	Bewehrung Trägerstege
Fr/Mo	Verlegen Vorspannung
Mo/Di	Bewehrung Fahrbahnplatte



10.03.2024



121



10.03.2024



122

Aufbringen der Vorspannung (SIA 262)

1. Spannprogramm (vorgängig festgelegt)

- Zeitpunkt und Reihenfolge der Spannstufen
- Vorausberechnete Dehnwege
- Erforderliche Druckfestigkeit des Betons

2. Spannprotokoll (beim Vorspannen)

- Alle wichtigen Beobachtungen während des Spannvorgangs, insbesondere
- Aufgebrachte Spannkräfte und gemessene Dehnwege

Zulässige Abweichung des Dehnwegs vom berechneten Sollwert:

- pro Spannglied 15%
- im Mittel über alle im gleichen Querschnitt verlaufenden Spannglieder $\leq 5\%$
- bei grösseren Abweichungen sind die Ursachen vor dem Injizieren abzuklären und die Auswirkungen auf das Tragwerk zu untersuchen.



























