

Substructure

(Unterbau)

Substructure – General remarks

The bridge substructure usually comprises:

- **abutments**
- **piers**
- **foundations**

The piers, abutments and foundations are virtually always **made from concrete** (even in a “steel bridge” or “timber bridge”).

Particularly for foundations and other elements in contact with backfill or water, **hardly any economical and durable alternatives** to concrete exist.

Exceptions are **steel piles** (H-profiles) and **sheet piles**, which are sometimes used in abutments or foundations, and reinforced earth abutment walls → examples at end of chapter.

Stone masonry was used before concrete and would still be a viable solution in many cases, but is usually only used in the rehabilitation of existing structures for economic reasons.



Example: Steel superstructure on stone masonry piers, concrete abutments (Ticino Bridge Atel, photo © Georg Aerni)

Abutments

Nomenclature and function



Classification / examples



Design



Dimensioning



Piers

General remarks and aesthetics



Construction



Design



Foundations

Types



Selected design aspects



Scour protection

Substructure

Abutments – Nomenclature and function

Substructure – **Abutments: Nomenclature and function**



Substructure – Abutments: Nomenclature and function

Bridge ends have to ensure the structural safety and serviceability of the bridge, the adjoining roadway or railway tracks, and the transition between them.

They consist of the following components:

- | | |
|--------------------|-----------------------|
| 1. abutment walls | = Widerlagerwände |
| 2. foundation | = Fundament |
| 3. wing walls | = Flügelmauern |
| 4. end diaphragm | = Endquerträger |
| 5. transition slab | = Schleppplatte |
| 6. access chamber | = Unterhaltsraum |
| 7. bearings | = Lager |
| 8. expansion joint | = Fahrbahnübergang |
| 9. subsoil | = Baugrund |
| 10. backfill | = Hinterfüllung |
| 11. adjoining road | = angrenzende Strasse |

The structural components of the bridge end are usually made from concrete (cast in place) and referred to as abutment = Widerlager

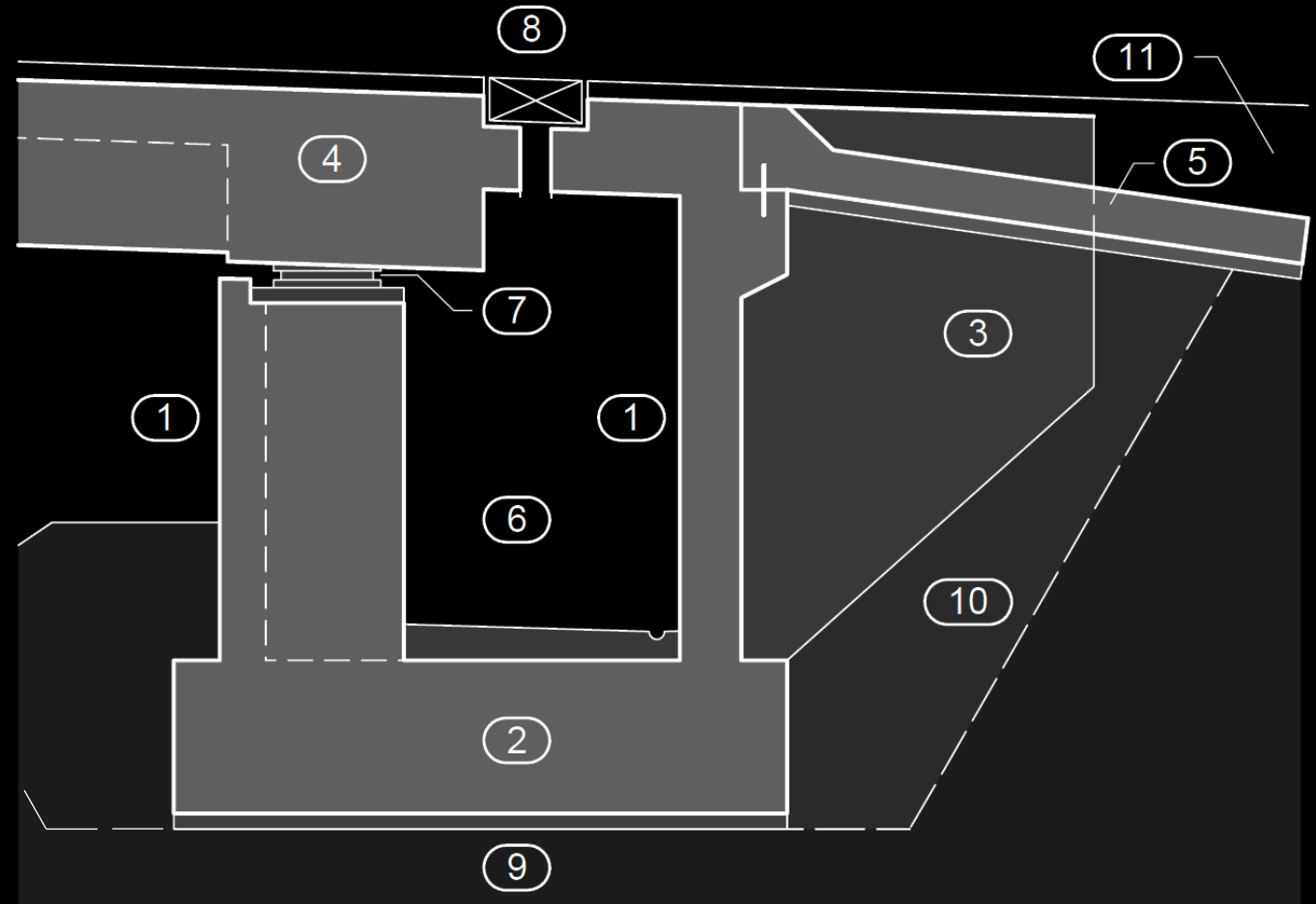

Substructure – Abutments: Nomenclature and function

Bridge ends have to ensure the structural safety and serviceability of the bridge, the adjoining roadway or railway tracks, and the transition between them.

They consist of the following components:

- | | |
|--------------------|-----------------------|
| 1. abutment walls | = Widerlagerwände |
| 2. foundation | = Fundament |
| 3. wing walls | = Flügelmauern |
| 4. end diaphragm | = Endquerträger |
| 5. transition slab | = Schleppplatte |
| 6. access chamber | = Unterhaltsraum |
| 7. bearings | = Lager |
| 8. expansion joint | = Fahrbahnübergang |
| 9. subsoil | = Baugrund |
| 10. backfill | = Hinterfüllung |
| 11. adjoining road | = angrenzende Strasse |

The structural components of the bridge end are usually made from concrete (cast in place) and referred to as **abutment = Widerlager**

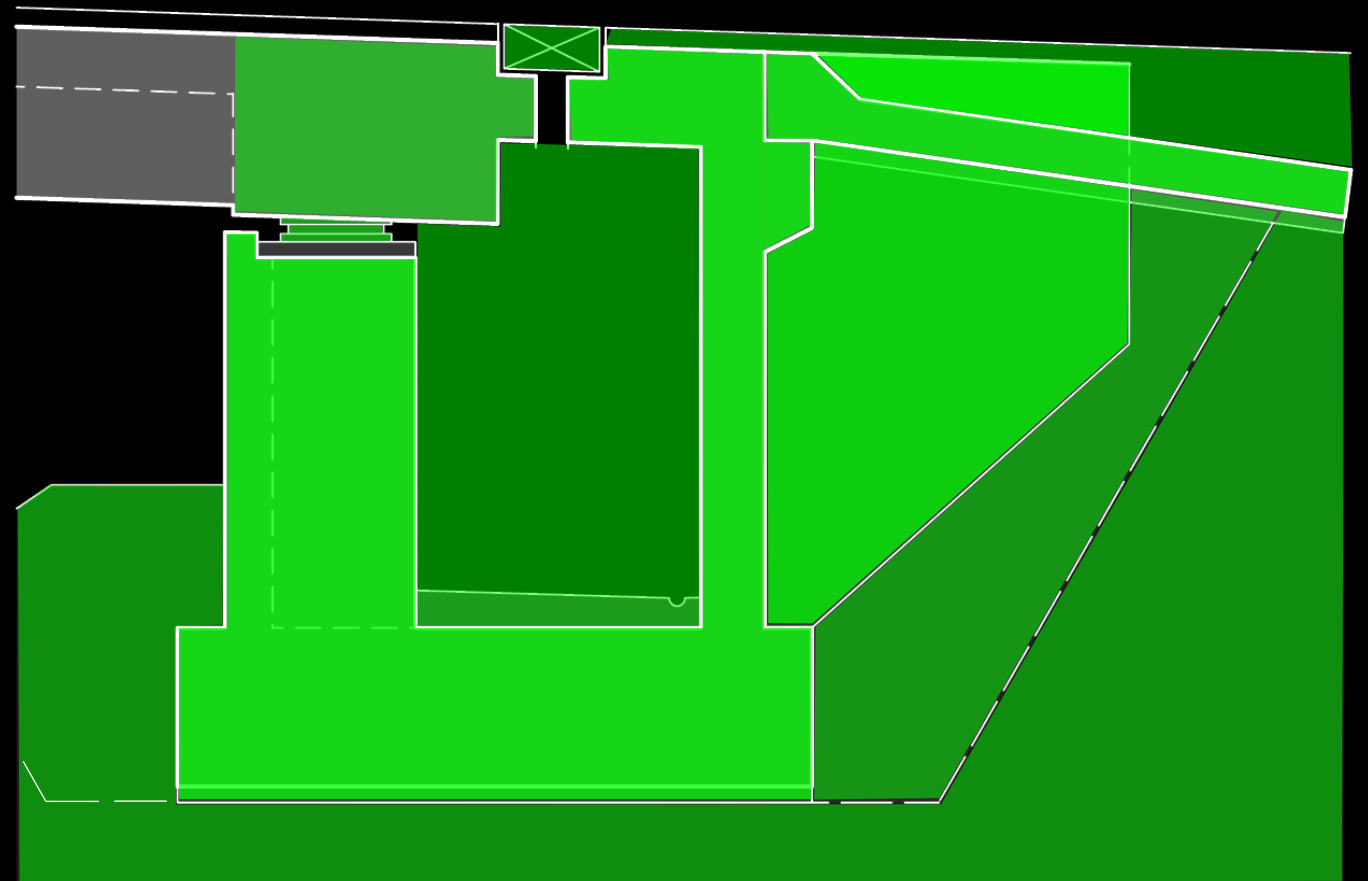

Substructure – Abutments: Nomenclature and function

Abutments typically need to comply with all or most of the following **functional requirements**:

- Resist vertical and horizontal support reactions of bridge deck and transfer them to the subgrade
- Resist actions from adjoining road / rail track (earth pressure, settlements, seepage water)
- Accommodate relative movements between bridge and adjoining road / rail track (temperature, shrinkage, creep, settlements, ...)
- Facilitate access for inspections and maintenance (accessibility of expansion joint, bearings, cables and pipes, drainage)
- Stiffen bridge end (limit vertical offsets of deck end and abutment, particularly for cantilevers)
- Facilitate passage of cables and pipes
- Ensure safety of bridge girder from falling in earthquakes
- Provide adequate scour protection (Kolkschutz)

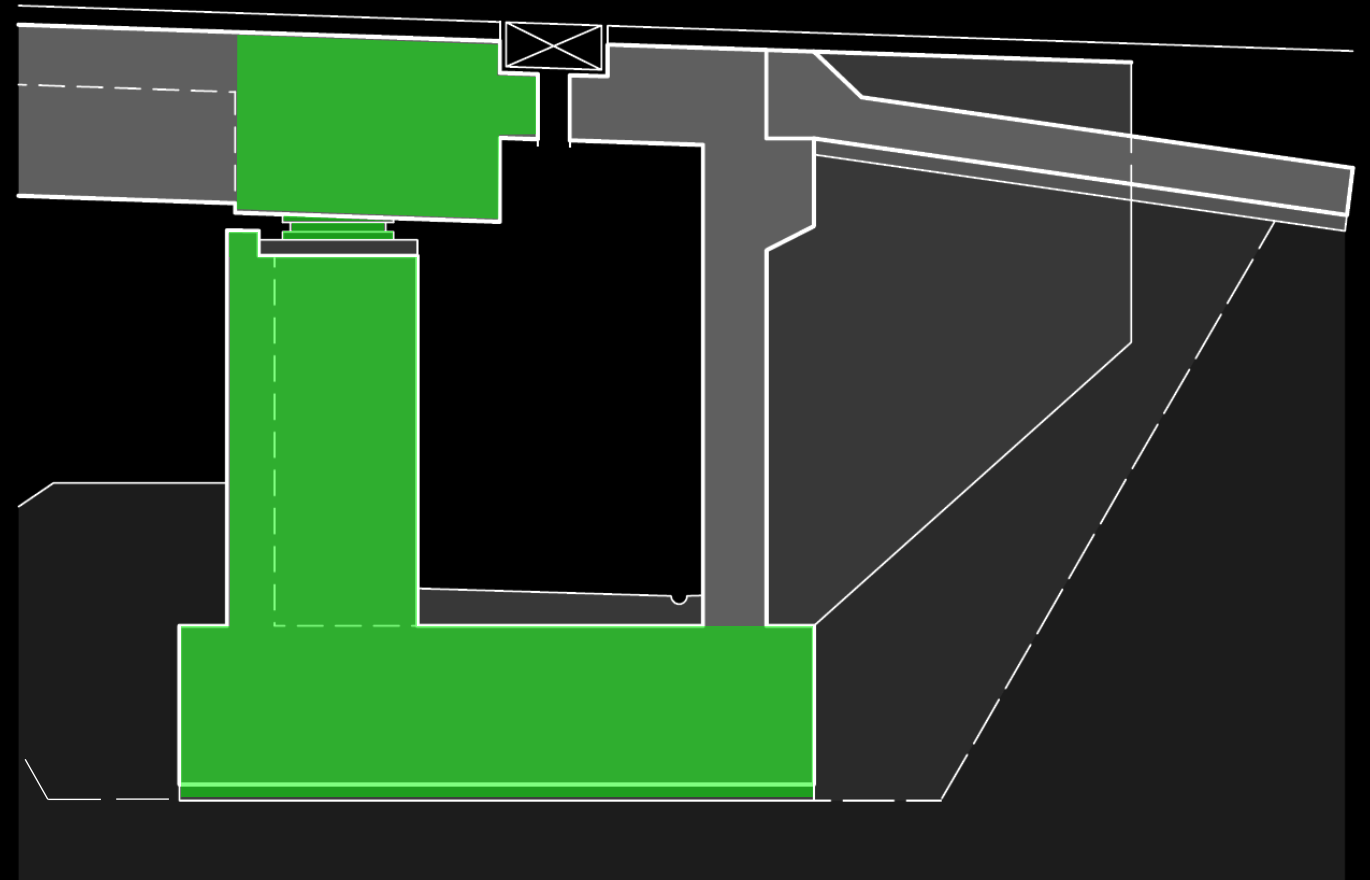

Substructure – Abutments: Nomenclature and function

Abutments typically need to comply with all or most of the following **functional requirements**:

- Resist vertical and horizontal support reactions of bridge deck and transfer them to the subgrade
- Resist actions from adjoining road / rail track (earth pressure, settlements, seepage water)
- Accommodate relative movements between bridge and adjoining road / rail track (temperature, shrinkage, creep, settlements, ...)
- Facilitate access for inspections and maintenance (accessibility of expansion joint, bearings, cables and pipes, drainage)
- Stiffen bridge end (limit vertical offsets of deck end and abutment, particularly for cantilevers)
- Facilitate passage of cables and pipes
- Ensure safety of bridge girder from falling in earthquakes
- Provide adequate scour protection (Kolkschutz)

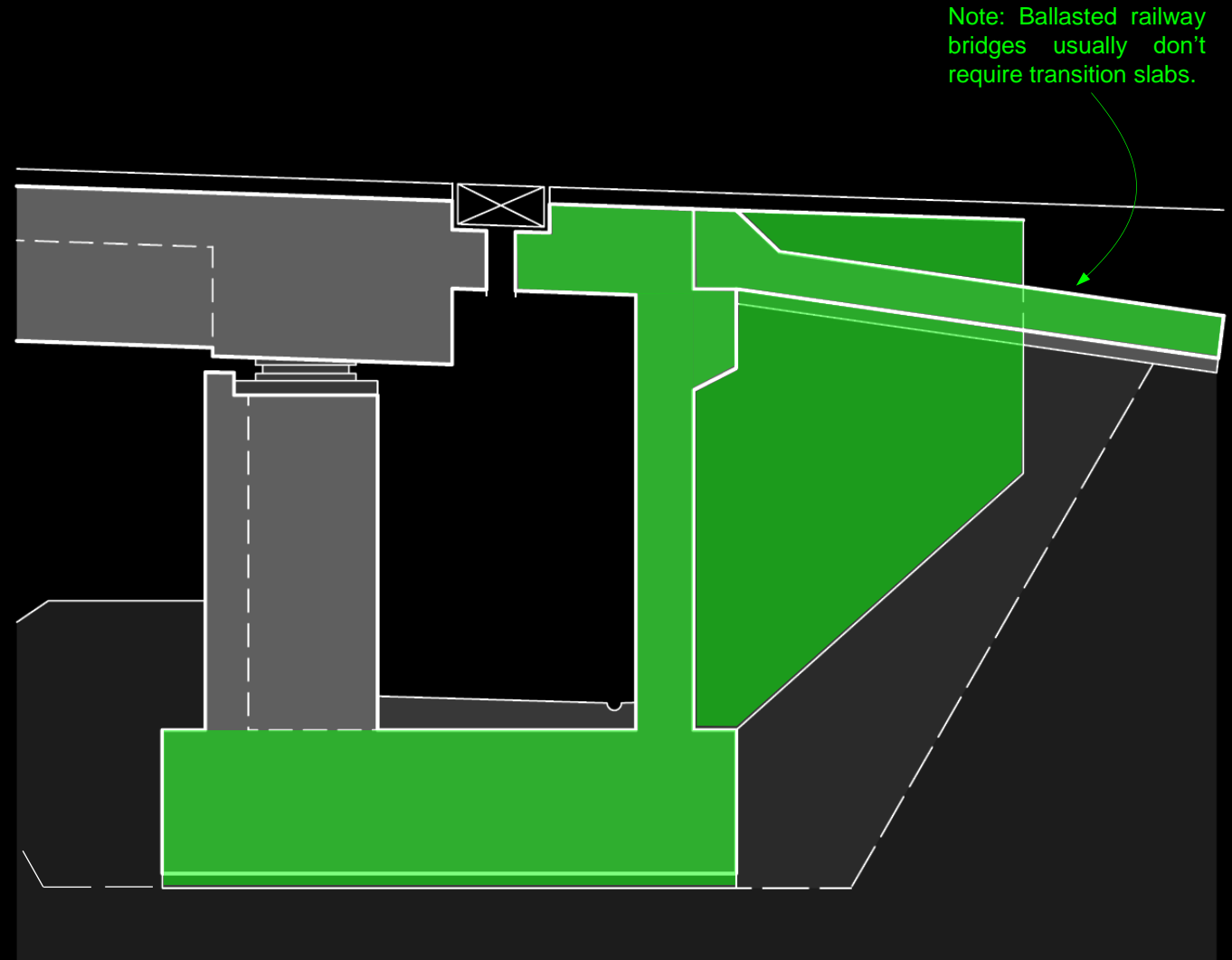

Substructure – **Abutments: Nomenclature and function**

Abutments typically need to comply with all or most of the following **functional requirements**:

- Resist vertical and horizontal support reactions of bridge deck and transfer them to the subgrade
- Resist actions from adjoining road / rail track (earth pressure, settlements, seepage water)
- **Accommodate relative movements between bridge and adjoining road / rail track (temperature, shrinkage, creep, settlements, ...)**
- Facilitate access for inspections and maintenance (accessibility of expansion joint, bearings, cables and pipes, drainage)
- Stiffen bridge end (limit vertical offsets of deck end and abutment, particularly for cantilevers)
- Facilitate passage of cables and pipes
- Ensure safety of bridge girder from falling in earthquakes
- Provide adequate scour protection (Kolkschutz)

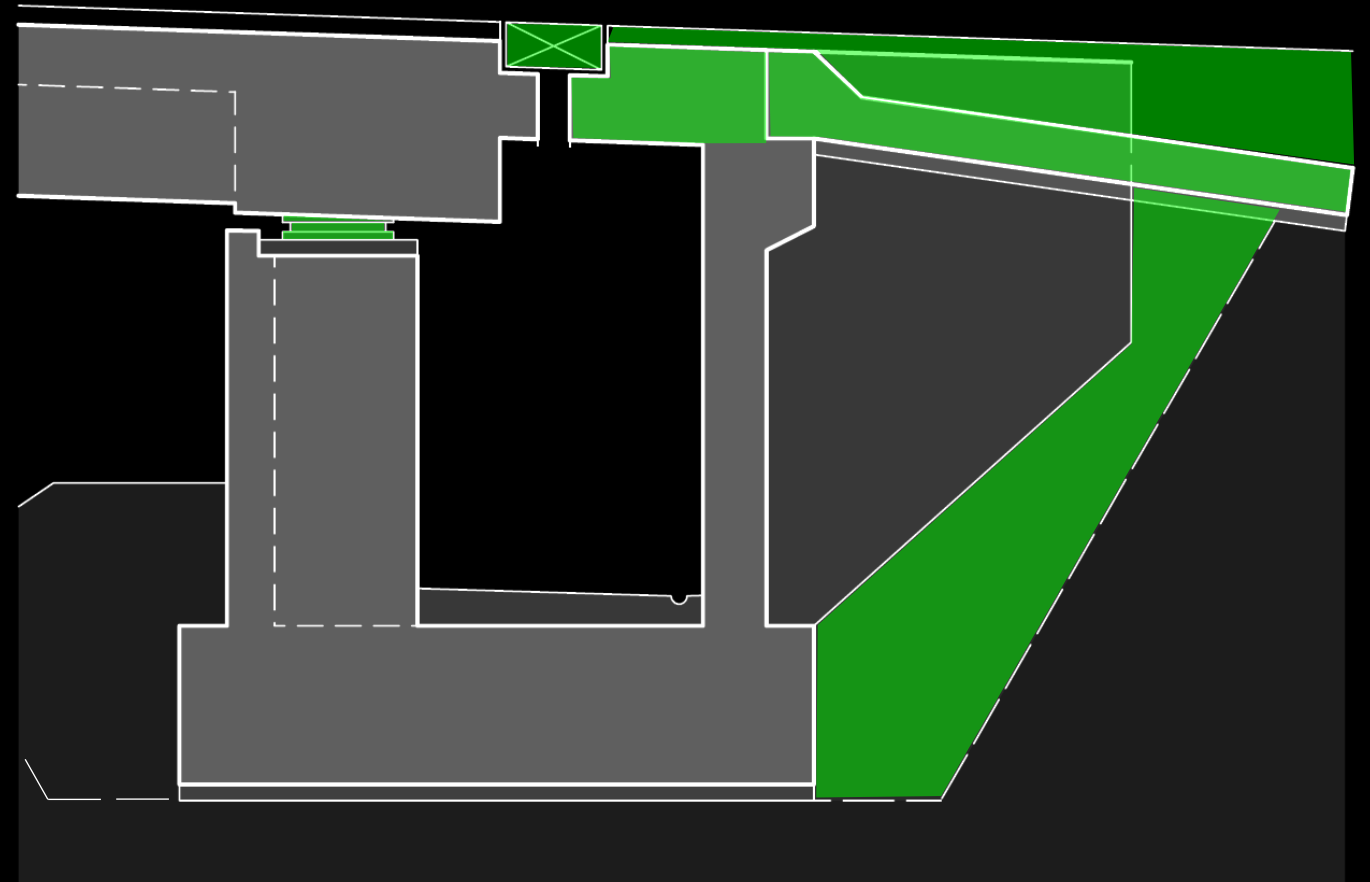

Substructure – **Abutments: Nomenclature and function**

Abutments typically need to comply with all or most of the following **functional requirements**:

- Resist vertical and horizontal support reactions of bridge deck and transfer them to the subgrade
- Resist actions from adjoining road / rail track (earth pressure, settlements, seepage water)
- Accommodate relative movements between bridge and adjoining road / rail track (temperature, shrinkage, creep, settlements, ...)
- **Facilitate access for inspections and maintenance (accessibility of expansion joint, bearings, cables and pipes, drainage)**
- Stiffen bridge end (limit vertical offsets of deck end and abutment, particularly for cantilevers)
- Facilitate passage of cables and pipes
- Ensure safety of bridge girder from falling in earthquakes
- Provide adequate scour protection (Kolkschutz)

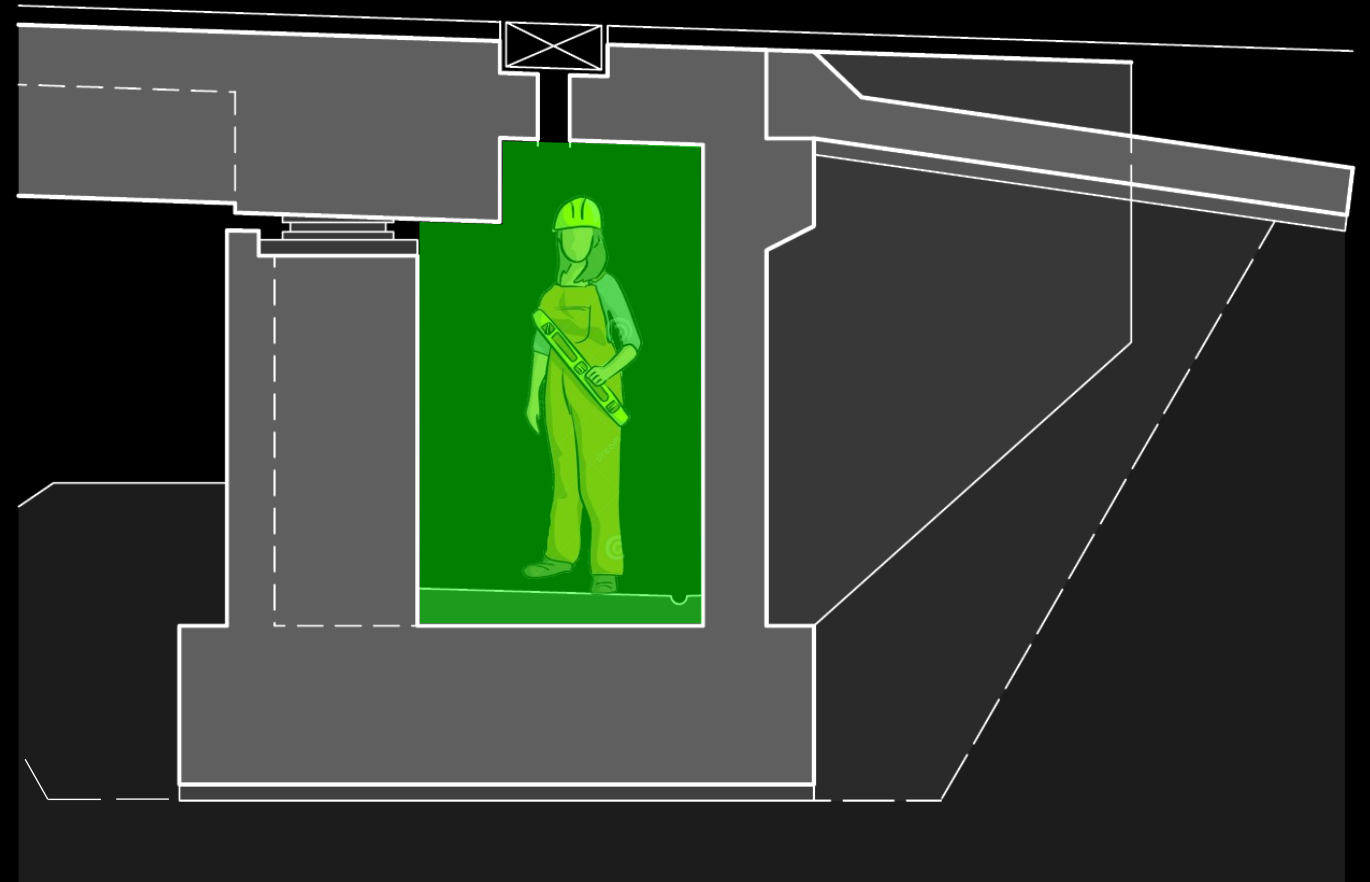

Substructure – Abutments: Nomenclature and function

Abutments typically need to comply with all or most of the following **functional requirements**:

- Resist vertical and horizontal support reactions of bridge deck and transfer them to the subgrade
- Resist actions from adjoining road / rail track (earth pressure, settlements, seepage water)
- Accommodate relative movements between bridge and adjoining road / rail track (temperature, shrinkage, creep, settlements, ...)
- Facilitate access for inspections and maintenance (accessibility of expansion joint, bearings, cables and pipes, drainage)
- **Stiffen bridge end (limit vertical offsets of deck end and abutment, particularly for cantilevers)**
- Facilitate passage of cables and pipes
- Ensure safety of bridge girder from falling in earthquakes
- Provide adequate scour protection (Kolkschutz)

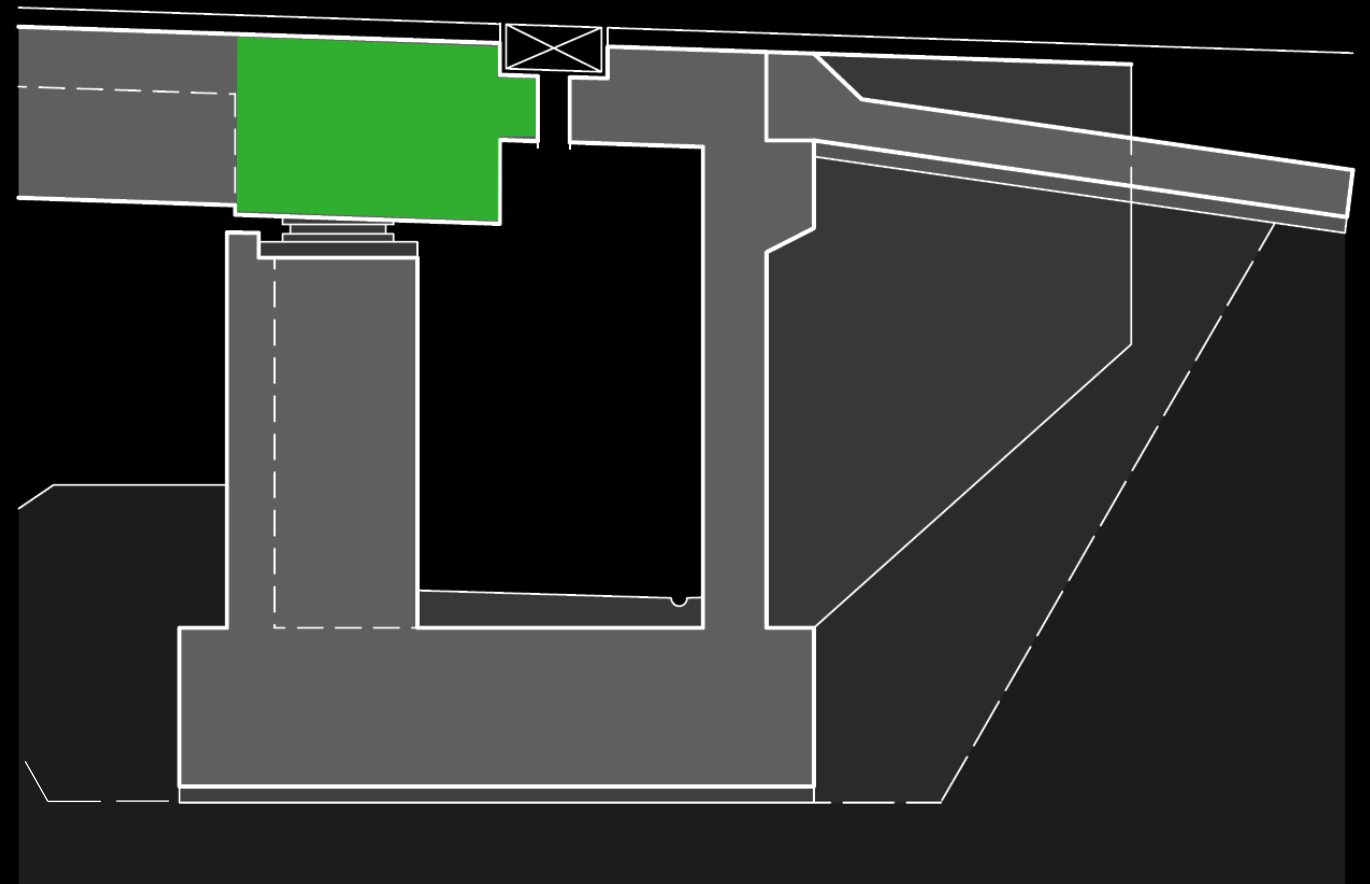

Substructure – **Abutments: Nomenclature and function**

Abutments typically need to comply with all or most of the following **functional requirements**:

- Resist vertical and horizontal support reactions of bridge deck and transfer them to the subgrade
- Resist actions from adjoining road / rail track (earth pressure, settlements, seepage water)
- Accommodate relative movements between bridge and adjoining road / rail track (temperature, shrinkage, creep, settlements, ...)
- Facilitate access for inspections and maintenance (accessibility of expansion joint, bearings, cables and pipes, drainage)
- Stiffen bridge end (limit vertical offsets of deck end and abutment, particularly for cantilevers)
- **Facilitate passage of cables and pipes**
- Ensure safety of bridge girder from falling in earthquakes
- Provide adequate scour protection (Kolkschutz)

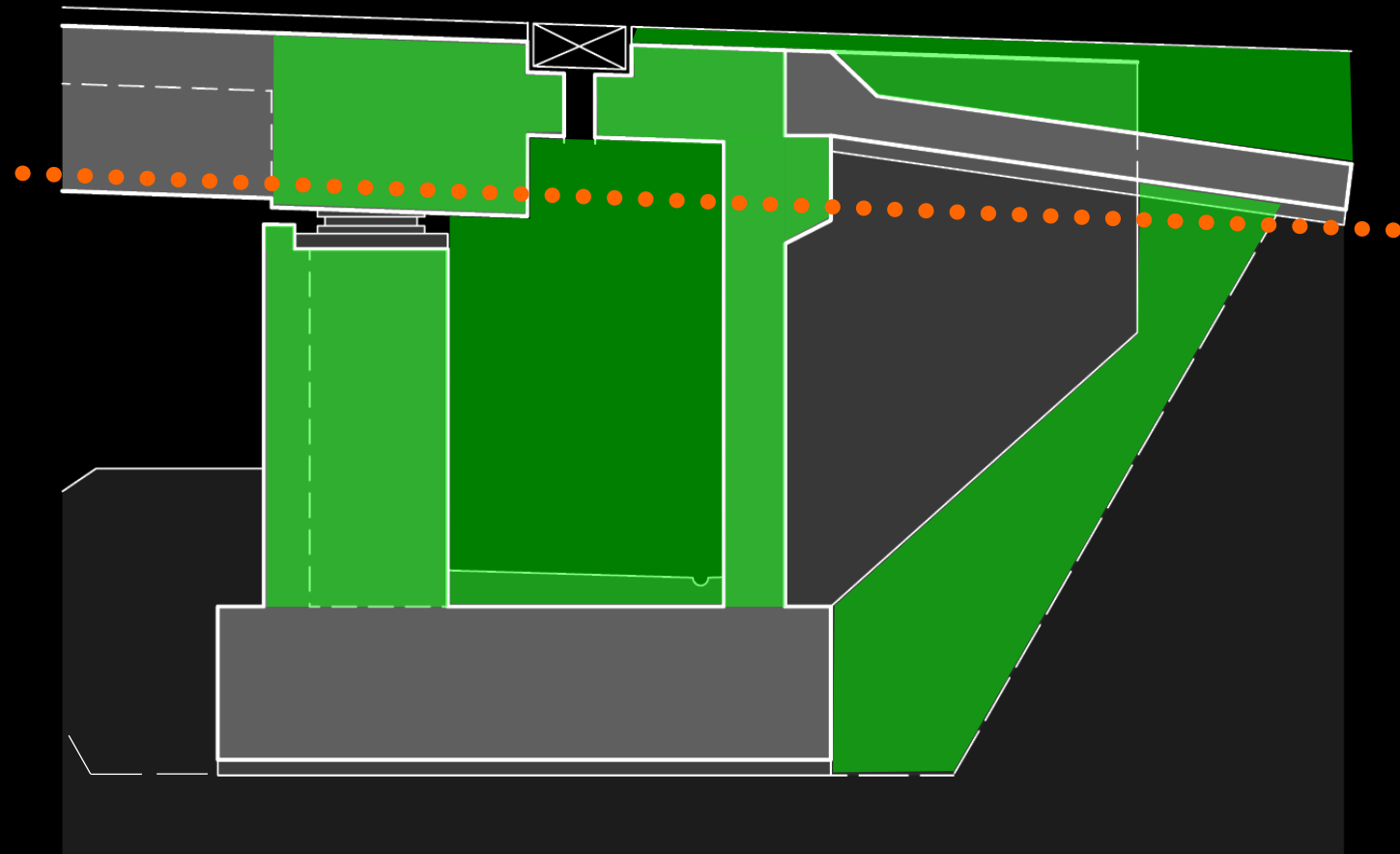

Substructure – **Abutments: Nomenclature and function**

Abutments typically need to comply with all or most of the following **functional requirements**:

- Resist vertical and horizontal support reactions of bridge deck and transfer them to the subgrade
- Resist actions from adjoining road / rail track (earth pressure, settlements, seepage water)
- Accommodate relative movements between bridge and adjoining road / rail track (temperature, shrinkage, creep, settlements, ...)
- Facilitate access for inspections and maintenance (accessibility of expansion joint, bearings, cables and pipes, drainage)
- Stiffen bridge end (limit vertical offsets of deck end and abutment, particularly for cantilevers)
- Facilitate passage of cables and pipes
- **Ensure safety of bridge girder from falling in earthquakes**
- Provide adequate scour protection (Kolkschutz)

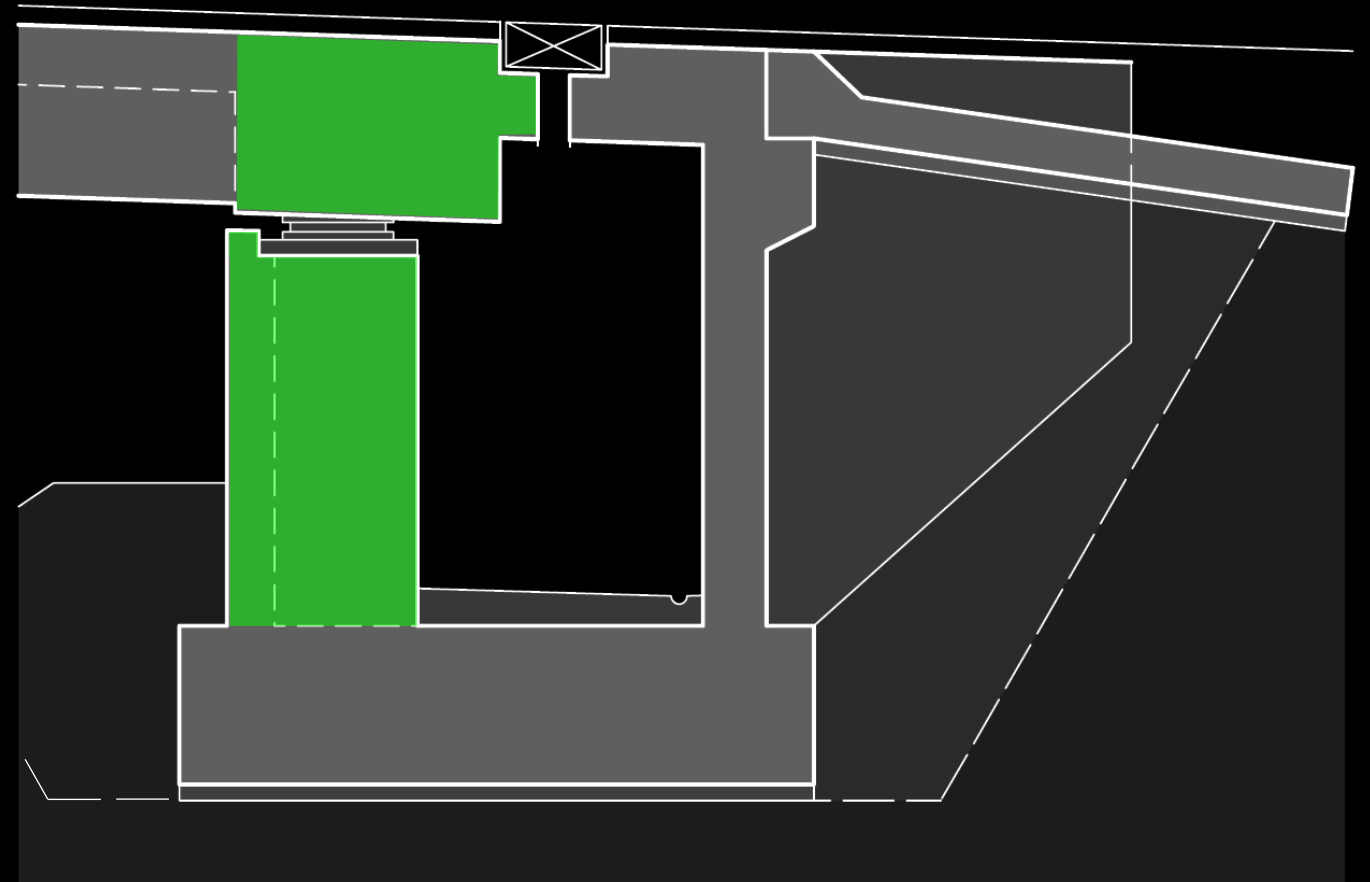

Substructure – **Abutments: Nomenclature and function**

Abutments typically need to comply with all or most of the following **functional requirements**:

- Resist vertical and horizontal support reactions of bridge deck and transfer them to the subgrade
- Resist actions from adjoining road / rail track (earth pressure, settlements, seepage water)
- Accommodate relative movements between bridge and adjoining road / rail track (temperature, shrinkage, creep, settlements, ...)
- Facilitate access for inspections and maintenance (accessibility of expansion joint, bearings, cables and pipes, drainage)
- Stiffen bridge end (limit vertical offsets of deck end and abutment, particularly for cantilevers)
- Facilitate passage of cables and pipes
- Ensure safety of bridge girder from falling in earthquakes
- **Provide adequate scour protection (Kolkschutz)**

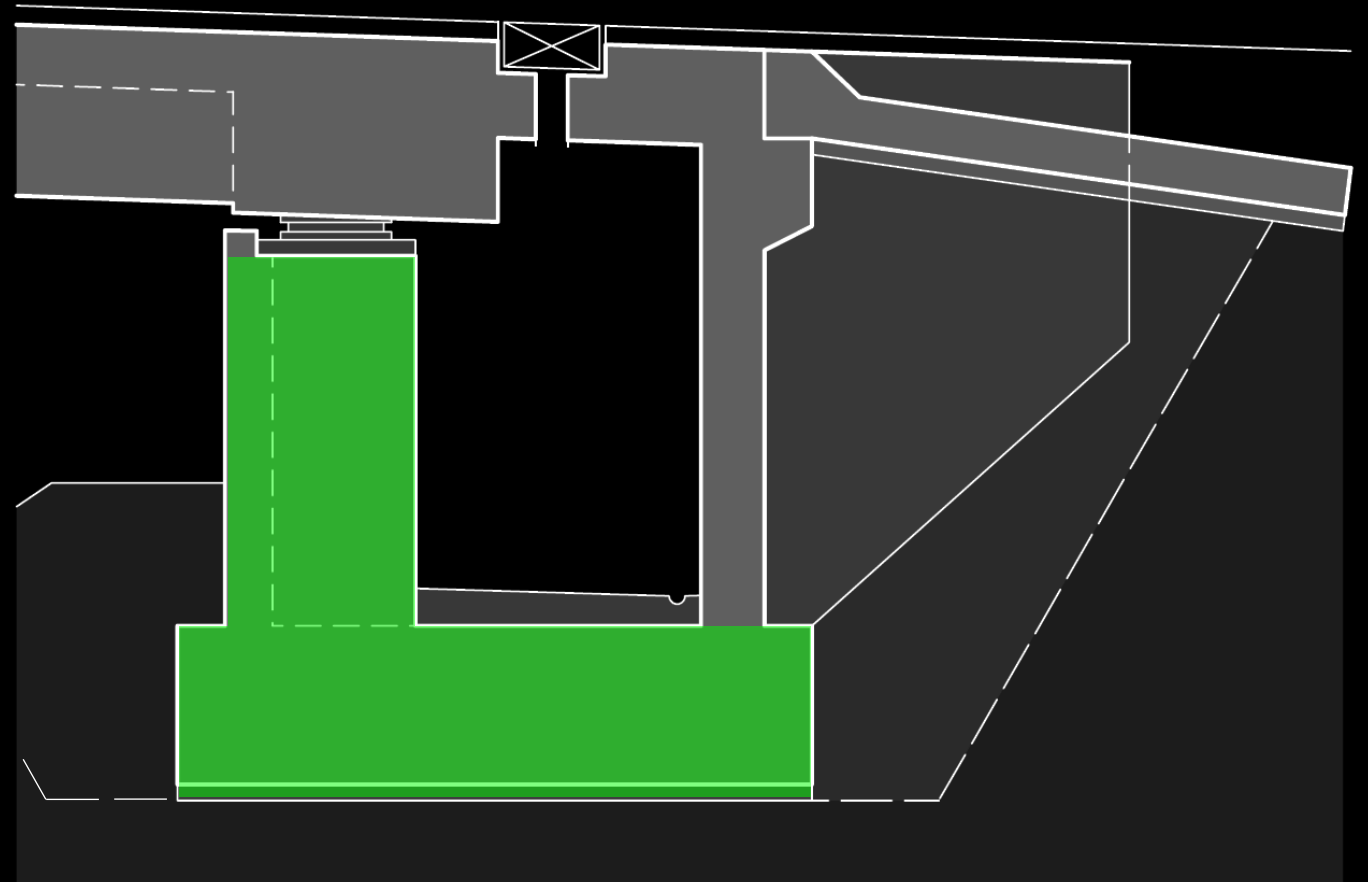

Substructure

Abutments – Classification / Examples

Substructure – Abutments: Classification / Examples

Technically, abutments can be classified depending on their functionality of the bridge end with respect to **support and articulation**:

- **Integral** abutments (without joints nor bearings)
- **Semi-integral** abutments (bearings, but no joints)
- **Jointed** abutments (bearings and expansion joint)
 - ... longitudinally fixed
 - ... horizontally movable

Apart from this distinction, classifying abutments is difficult since their **design differs strongly**, depending on the **local / regional preferences** of clients and designers.

On the following slides, some **basic criteria** are discussed, and **examples** illustrating the **wide range of alternatives** are shown, with emphasis on the Swiss state of practice.

Note that mainly jointed abutments are shown for illustration, but integral abutments are preferred.

Integral bridge ends (neither expansion joint nor bearing)

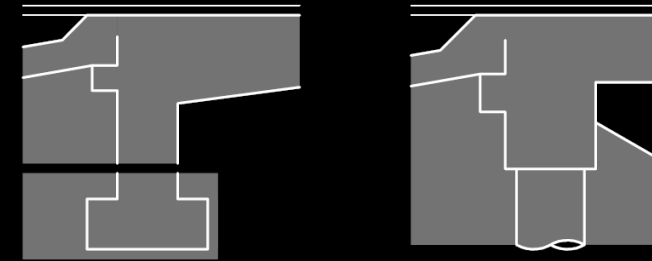

Semi-integral bridge ends (bearing only)

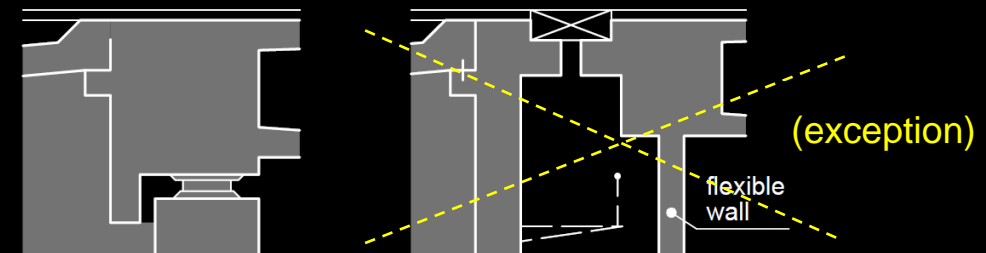

Jointed bridge ends (with expansion joint and bearing)

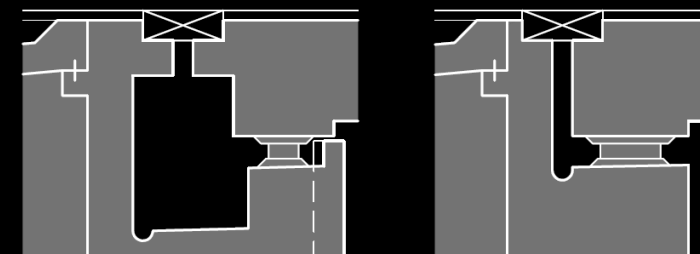

Substructure – Abutments: Classification / Examples

The **abutments**, forming the **structural part of the bridge end**, connect the bridge to the adjoining road or railway. Naturally, the design of the abutments is **essential for the integration of a bridge** in a site.

The following parameters have to be selected in design:

- **positioning of abutments in plan**
 - length of bridge and embankments, respectively
 - height of abutment (visual impact)
 - **orientation of the wing walls**
 - embankment geometry
 - **design of abutment itself**
 - perception by users
- decisive for **integration** and **aesthetic quality** of a bridge
- even more pronounced when crossing **flat areas** (next slides)

Full height / High stem abutment:

- ... short bridge
- ... high abutment (and approach embankment)
- ... high visual impact

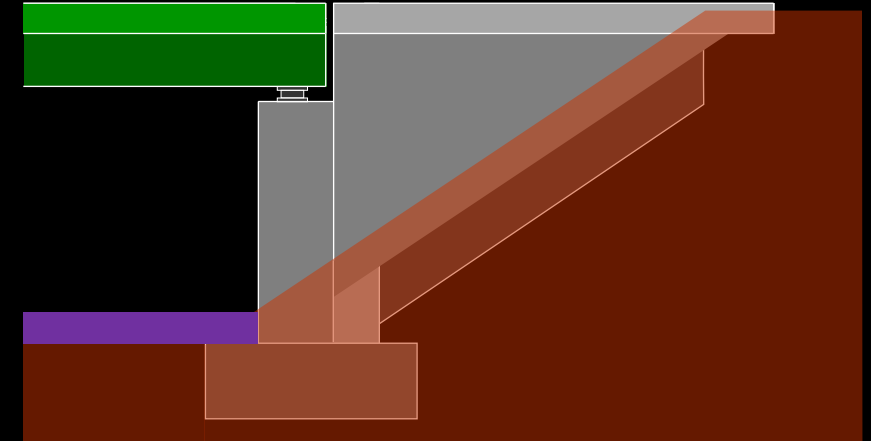

Stub abutment / Short stem abutment:

- ... long bridge
- ... low abutment (and approach embankment)
- ... unobtrusive

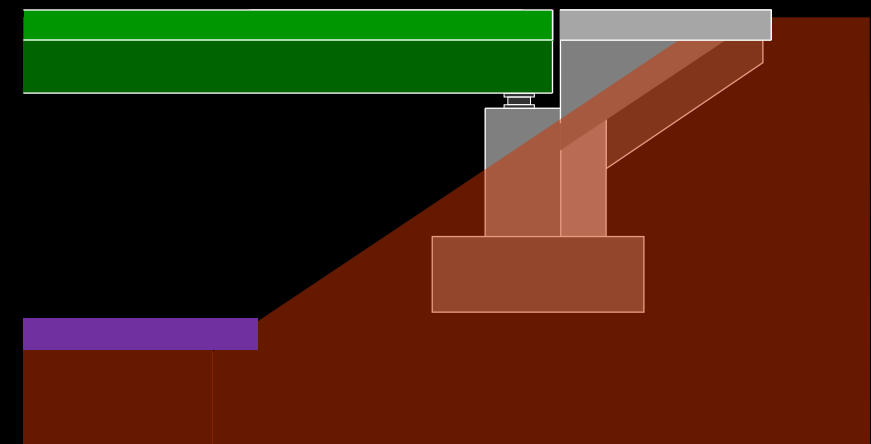

Substructure – Abutments: Classification / Examples

The **abutments**, forming the **structural part of the bridge end**, connect the bridge to the adjoining road or railway. Naturally, the design of the abutments is **essential for the integration of a bridge** in a site.

The following parameters have to be selected in design:

- **positioning of abutments in plan**
 - length of bridge and embankments, respectively
 - height of abutment (visual impact)
 - **orientation of the wing walls**
 - embankment geometry
 - **design of abutment itself**
 - perception by users
- decisive for **integration** and **aesthetic quality** of a bridge
- even more pronounced when crossing **flat areas** (next slides)

**Full height abutment/
High stem abutment:**

- ... short bridge
- ... high abutment (and approach embankment)
- ... high visual impact



**Stub abutment /
Short stem abutment:**

- ... long bridge
- ... low abutment (and approach embankment)
- ... unobtrusive



Substructure – Abutments: Classification / Examples

Example: Stub abutment with additional span (compared to alternative with full height abutment)



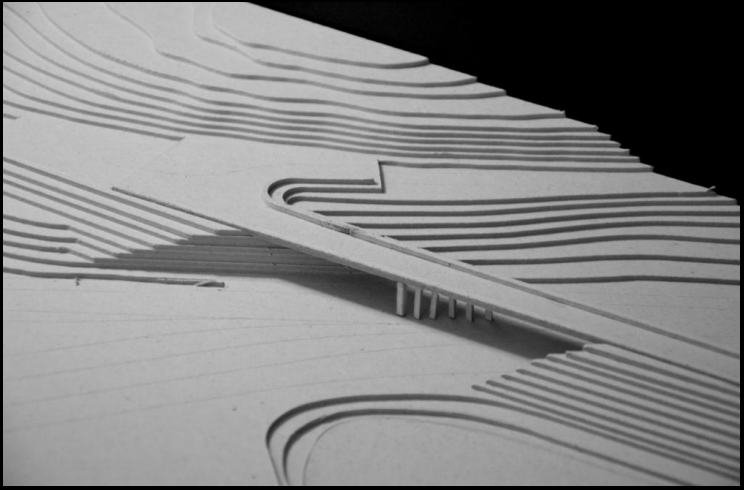
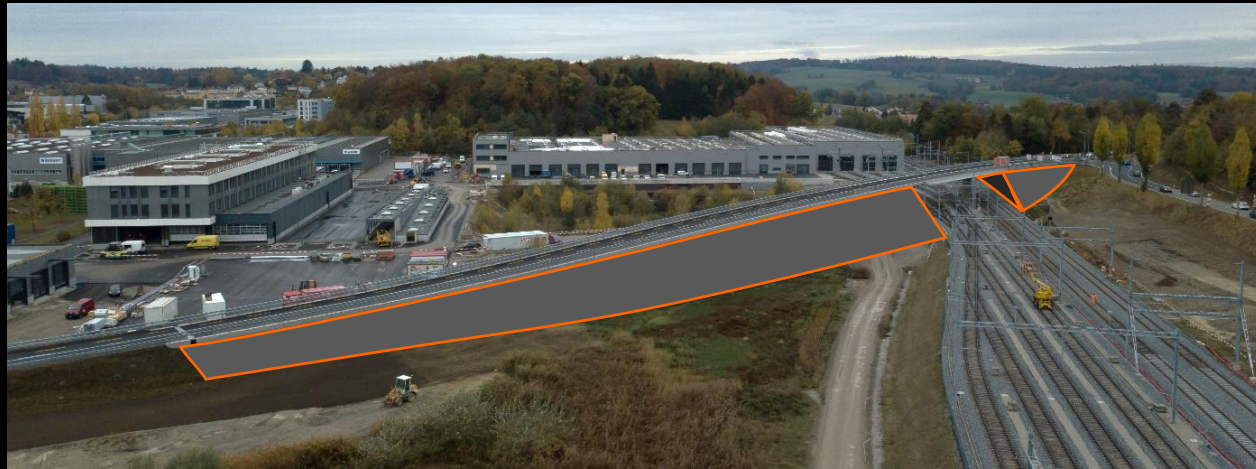
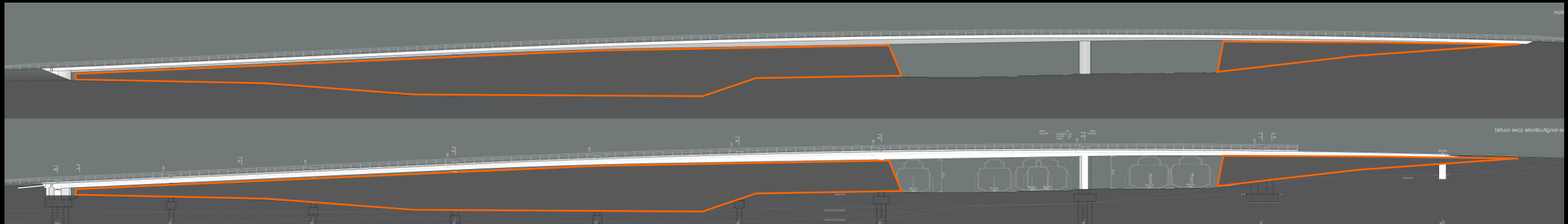







Substructure – Abutments: Classification / Examples

Exposed bearing seat
Without support diaphragm
Without access chamber

- low initial cost
- minimalist appearance
- uplift may be critical
(limited separation of bearings)
- inconvenient maintenance
... bearings accessible via embankment only
- limited durability
... expansion joint inaccessible
(leakages may remain undetected)
... expansion joint in cantilevers subject to vertical offsets due to traffic load

Note: Integral abutments may have equally minimalist designs, without the drawbacks mentioned above.

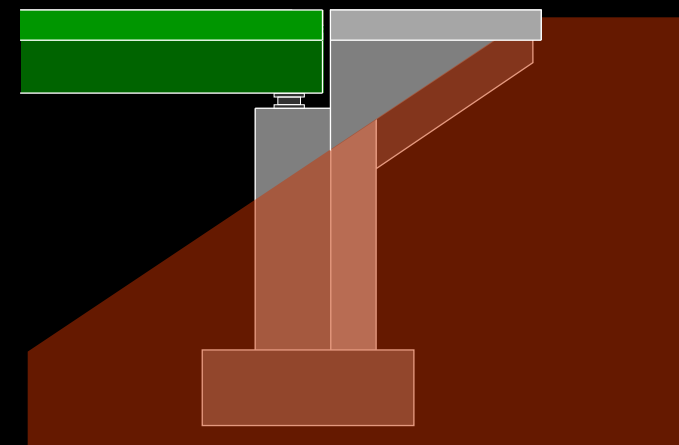
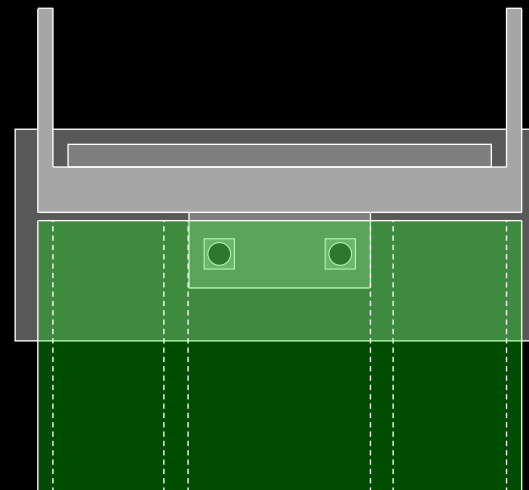
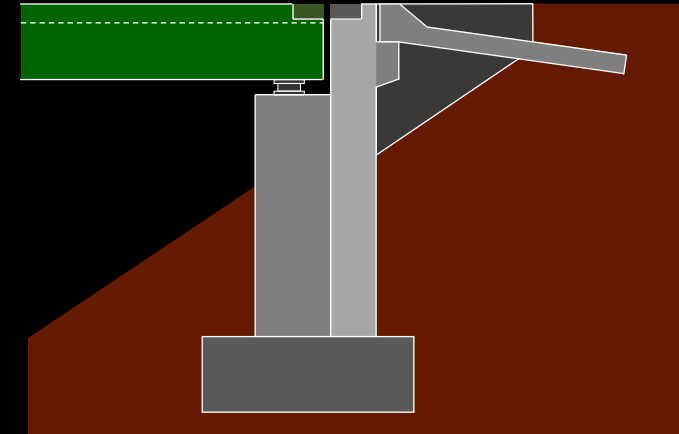
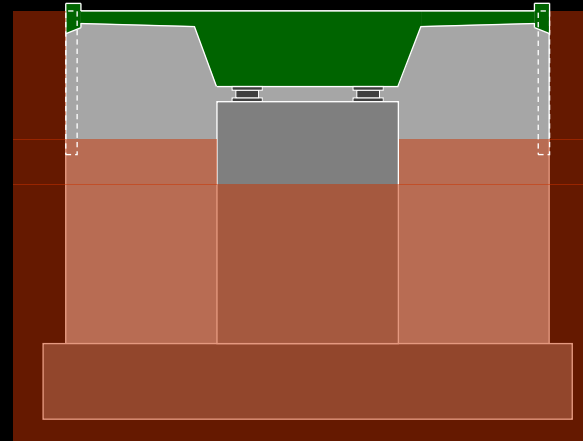



Substructure – Abutments: Classification / Examples

Exposed bearing seat
Without support diaphragm
Without access chamber

This slide shows alternatives with different wing wall orientation. These are

- basically possible in all solutions that follow (illustrated only here for the sake of simplicity)
- should be separated from flexible integral abutments to avoid excessive restraint

Note that the length of the wing walls depends on the embankment geometry (here, a slope of 2:3 parallel to the wing walls is assumed for simplification). Wing walls and retaining walls should **always be designed with some extra length** (if they are too long, they will simply be buried – but too short ones require ugly, often improvised measures).

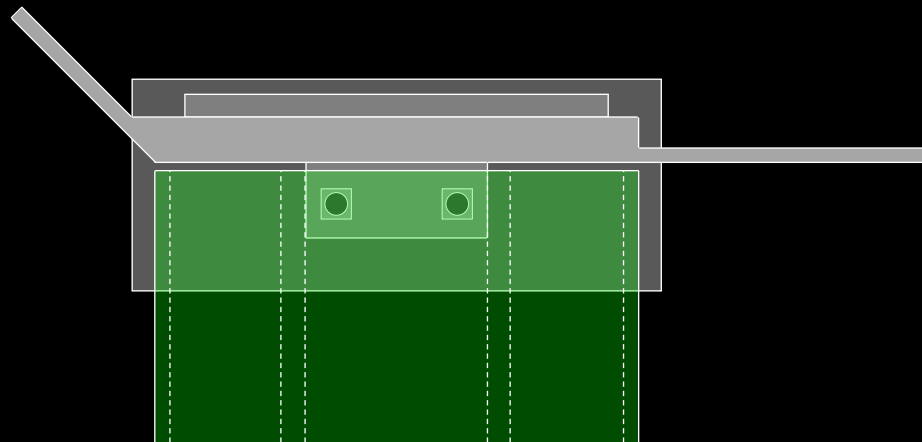
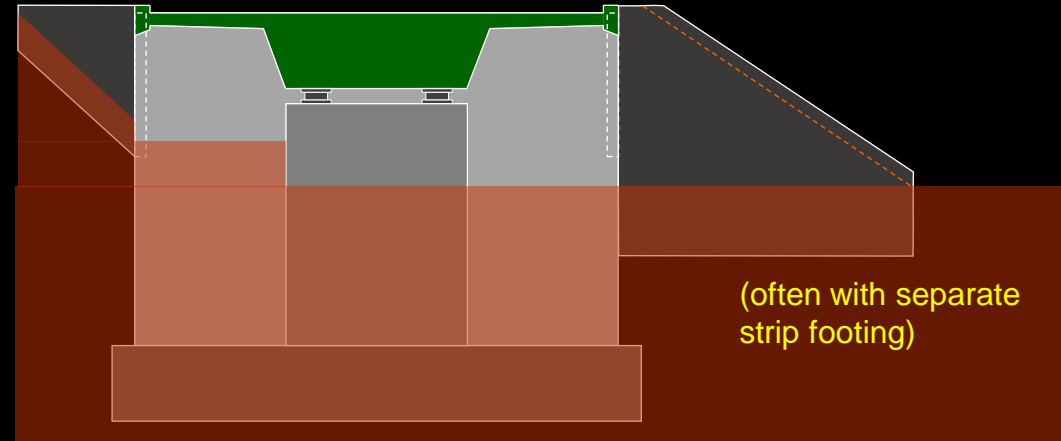

Substructure – Abutments: Classification / Examples

Exposed bearing seat
Exposed support diaphragm
Without access chamber

- low initial cost
- uplift hardly critical
(large separation of bearings)
- unsatisfactory appearance
 - ... end diaphragm fully visible
 - ... wide stem
- inconvenient maintenance
 - ... bearings accessible via embankment only
- limited durability
 - ... expansion joint inaccessible
(leakages may remain undetected)

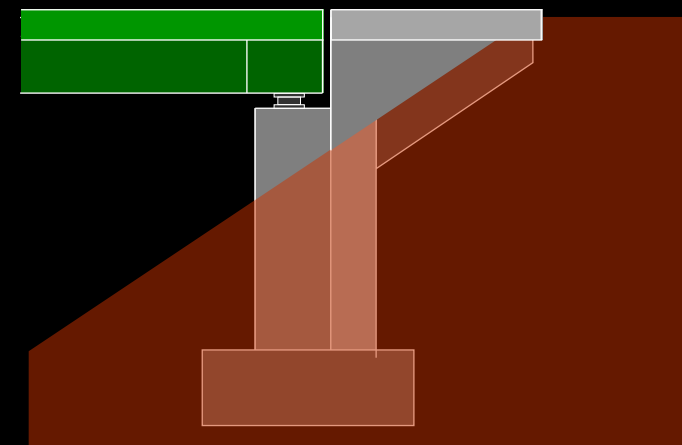
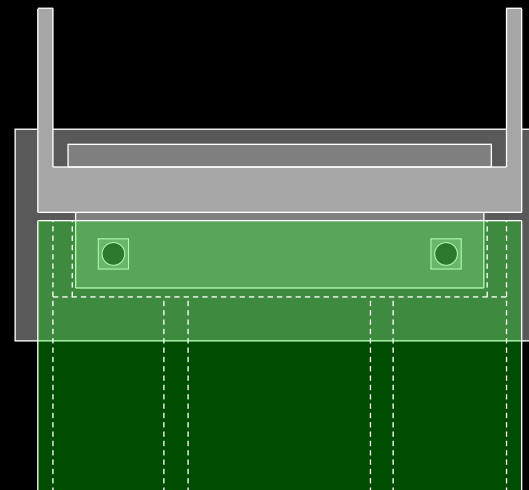
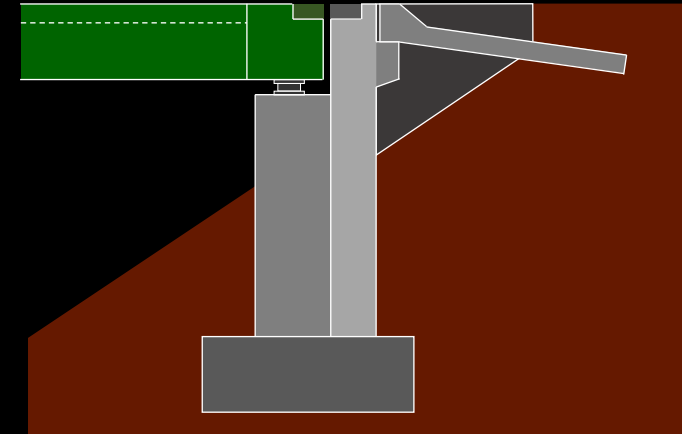
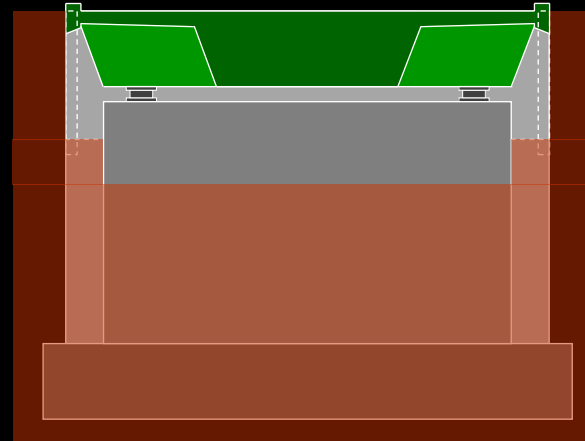









Substructure – Abutments: Classification / Examples

Integrated bearing seat
Partially hidden support diaphragm (cheek walls)
With access chamber

- **high durability**
... expansion joint accessible
(leakages may be detected)
- **maintenance friendly**
... bearings accessible via chamber
- **uplift hardly critical**
(large separation of bearings)
- **regular appearance**
... end diaphragm and bearings partly visible
... visible horizontal offset (end diaphragm-
abutment wall) due to girder contraction
- **high initial cost**

Note: Open abutments can also be built with an access chamber (in the drawing to the right, just the front part of wing walls needs to be removed)

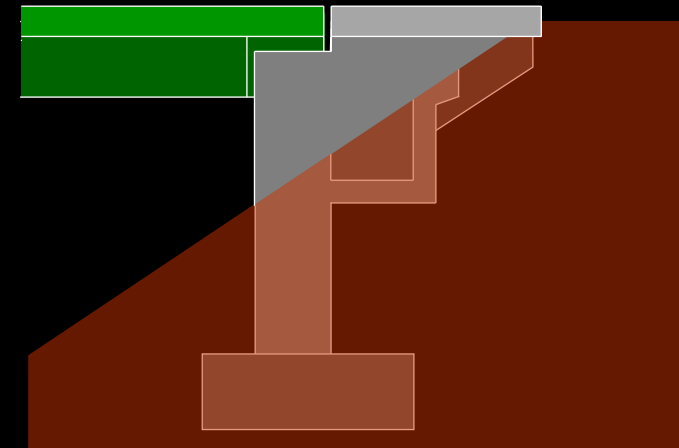
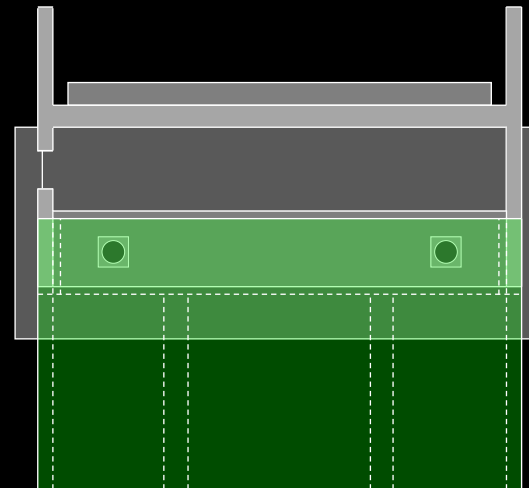
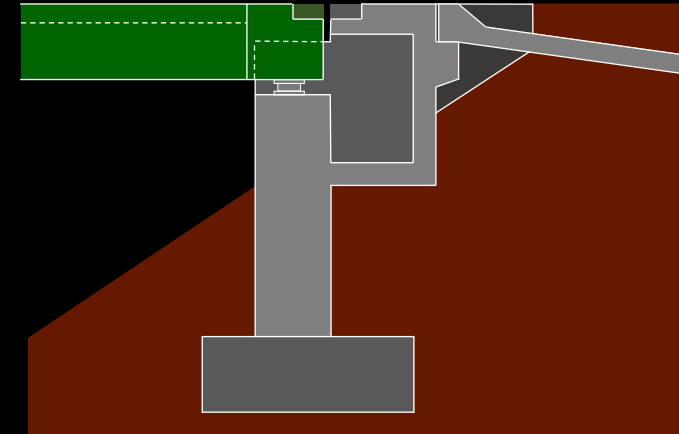
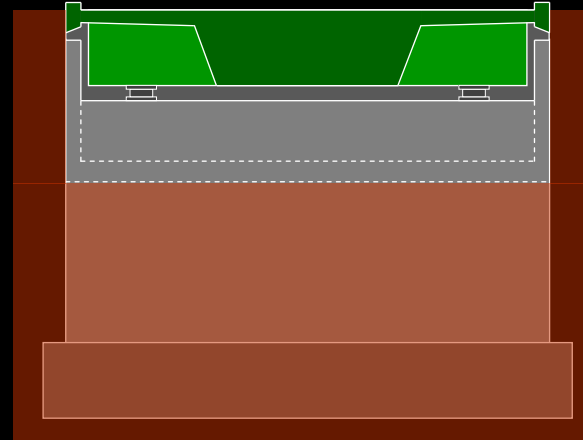











Substructure – Abutments: Classification / Examples

Integrated bearing seat
Hidden support diaphragm
With access chamber

- **high durability**
... expansion joint accessible
(leakages may be detected)
- **maintenance friendly**
... bearings accessible via chamber
- **uplift hardly critical**
(large separation of bearings)
- **clean and tidy appearance**
... end diaphragm and bearings fully hidden
... horizontal offset due to girder contraction hidden
- **high initial cost**

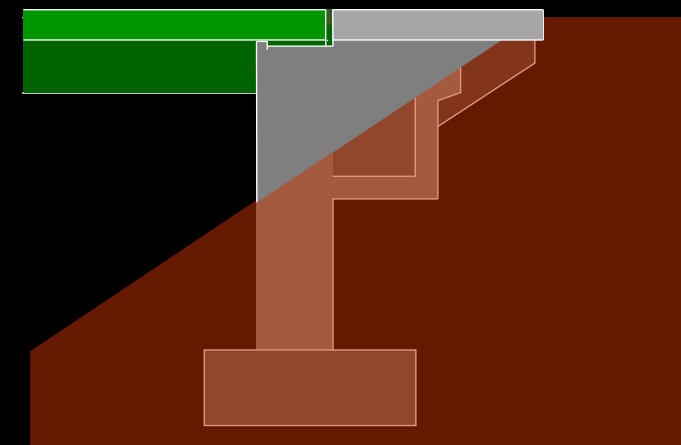
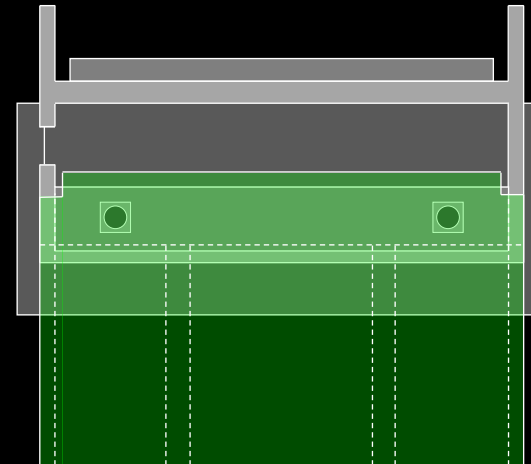
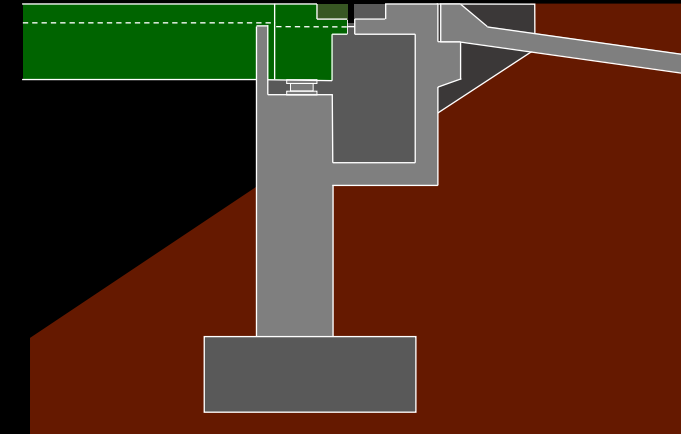
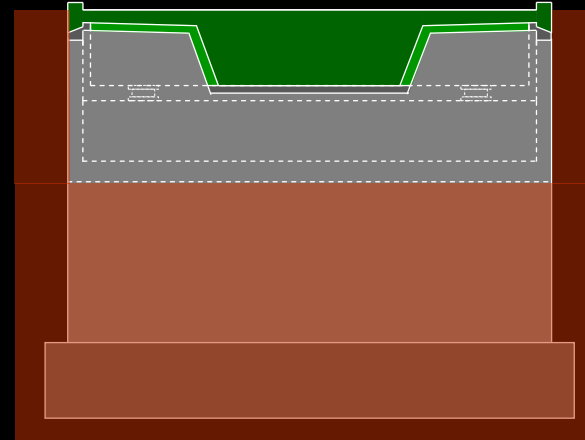



Substructure – Abutments: Classification / Examples

Integral abutment (flexible)

- **maximum durability**
... neither expansion joint nor bearings
- **minimum maintenance**
... neither expansion joint nor bearings
... **pavement cracks may occur**
- **no uplift problems**
(abutment weight can be activated in case)
- **clean and tidy appearance**
... hardly visible transition from bridge to abutment
(joints between wing walls and front wall only)
... **horizontal offset due to girder contraction may become visible**

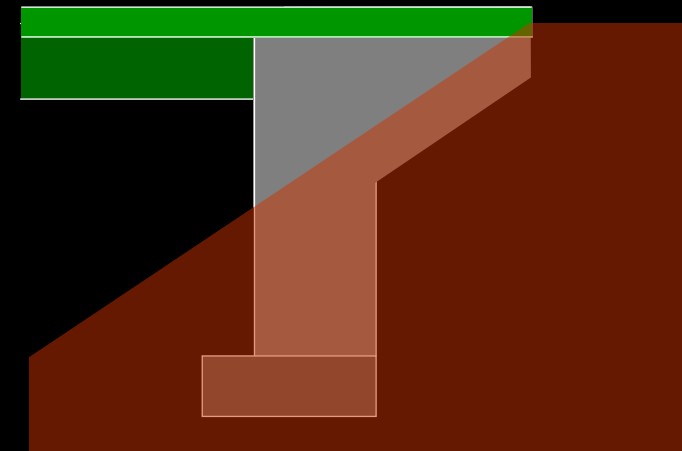
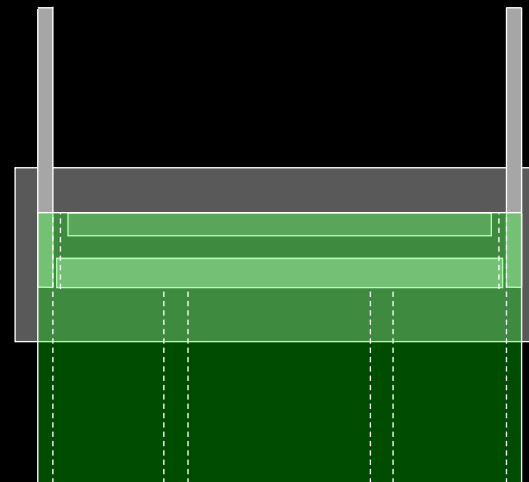
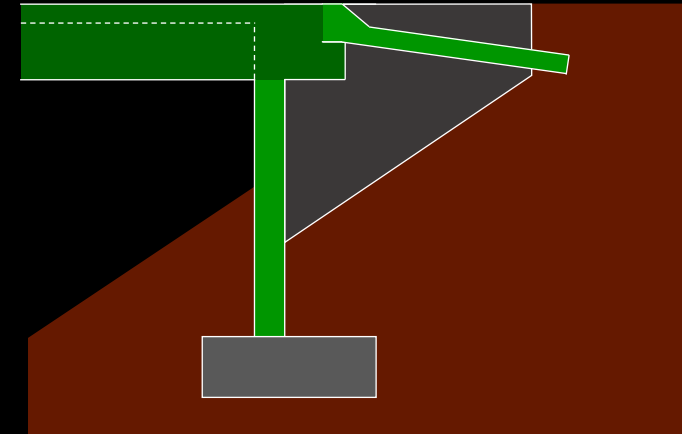
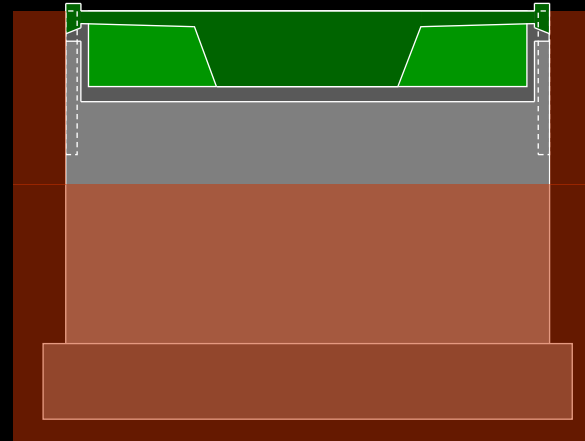

Substructure – Abutments: Classification / Examples

Integral abutment (flexible)

- **maximum durability**
... neither expansion joint nor bearings
- **minimum maintenance**
... neither expansion joint nor bearings
... **pavement cracks may occur**
- **no uplift problems**
(abutment weight can be activated in case)
- **clean and tidy appearance**
... hardly visible transition from bridge to abutment
(joints between wing walls and front wall only)
... **horizontal offset due to girder contraction may become visible**

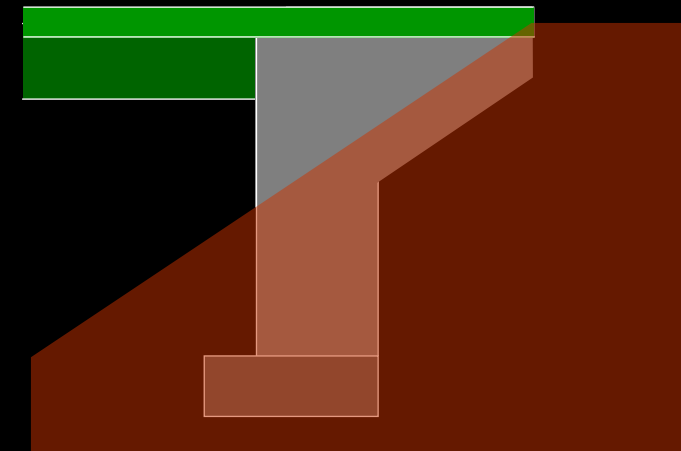
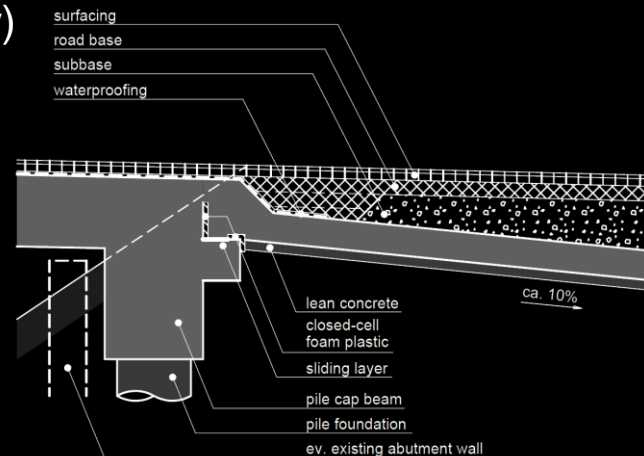
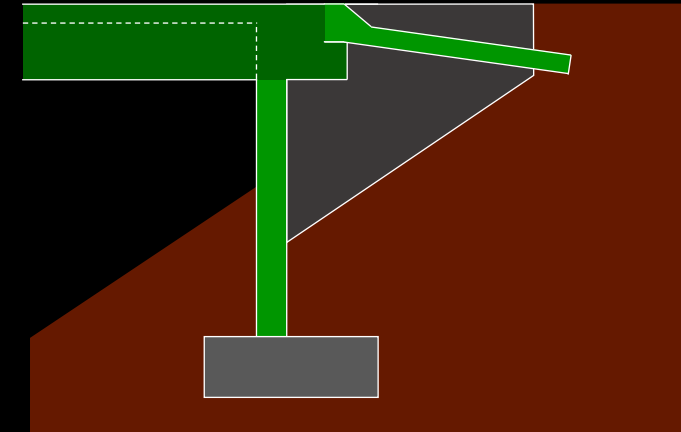
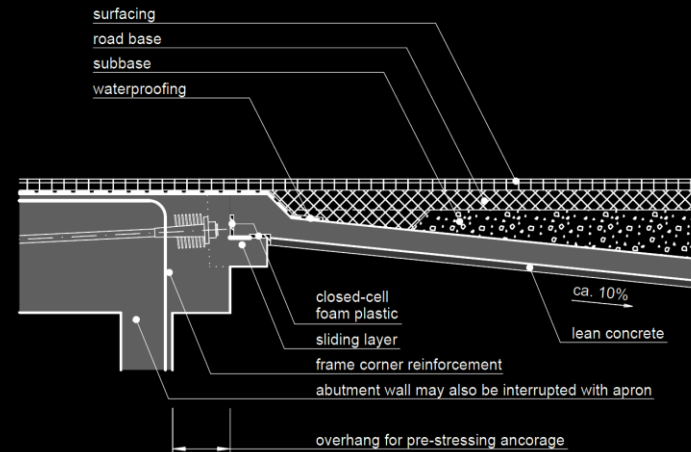

Substructure – Abutments: Classification / Examples



Substructure – Abutments: Classification / Examples

Integral abutment (stiff)

- **maximum durability**
... neither expansion joint nor bearings
- **minimum maintenance**
... neither expansion joint nor bearings
... **pavement cracks may occur**
- **no uplift problems**
(abutment weight can be activated in case)
- **clean and tidy appearance**
... smooth transition from bridge to abutment
(no joints between wing walls and front wall)
... no horizontal offset due to girder contraction

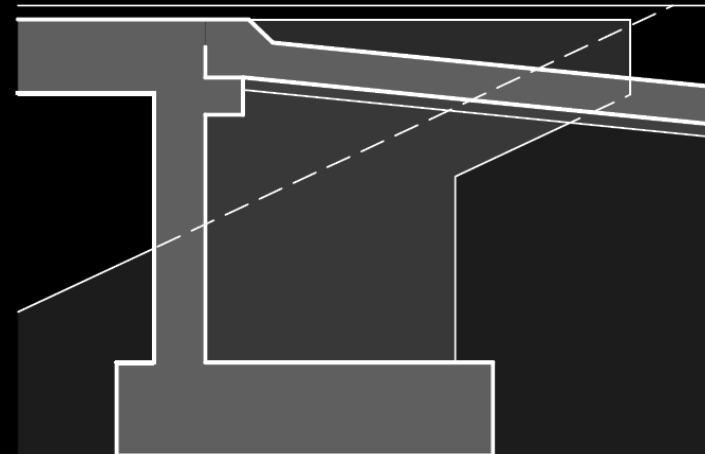

frame type

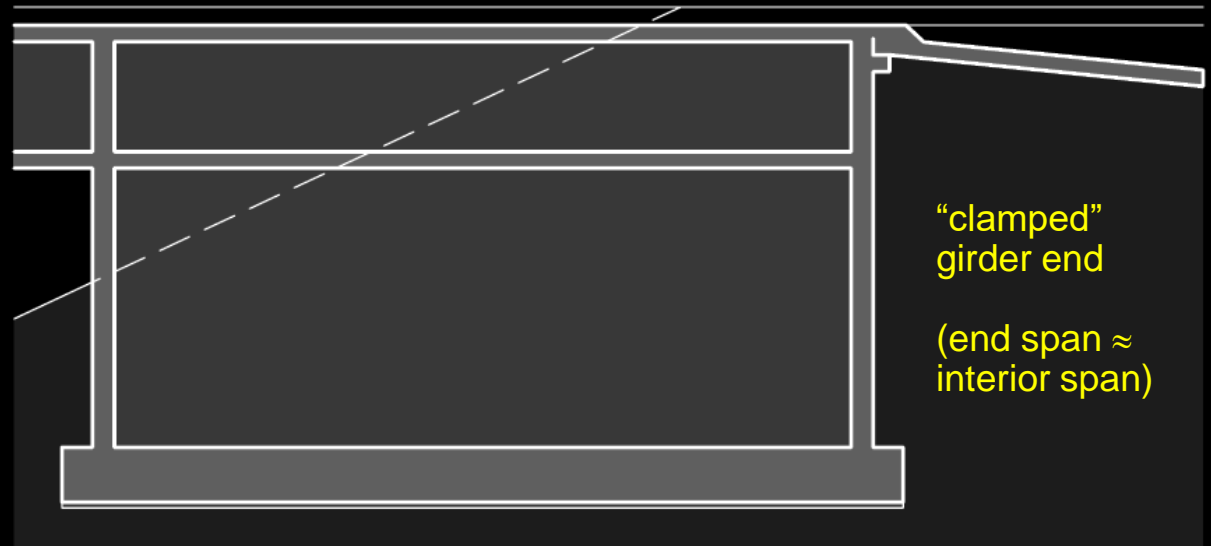

"clamped"
girder end

(end span \approx
interior span)







Substructure – Abutments: Classification / Examples

Semi-integral abutment

- **very high durability**
... no expansion joint, just bearings
- **low maintenance**
... no expansion joint, just bearings
... **pavement cracks may occur**
- **uplift hardly critical**
(wide separation of bearings, load on transition slab can be activated)
- **regular appearance**
... end diaphragm and bearings partly visible
... visible horizontal offset (end diaphragm-abutment wall) due to girder contraction

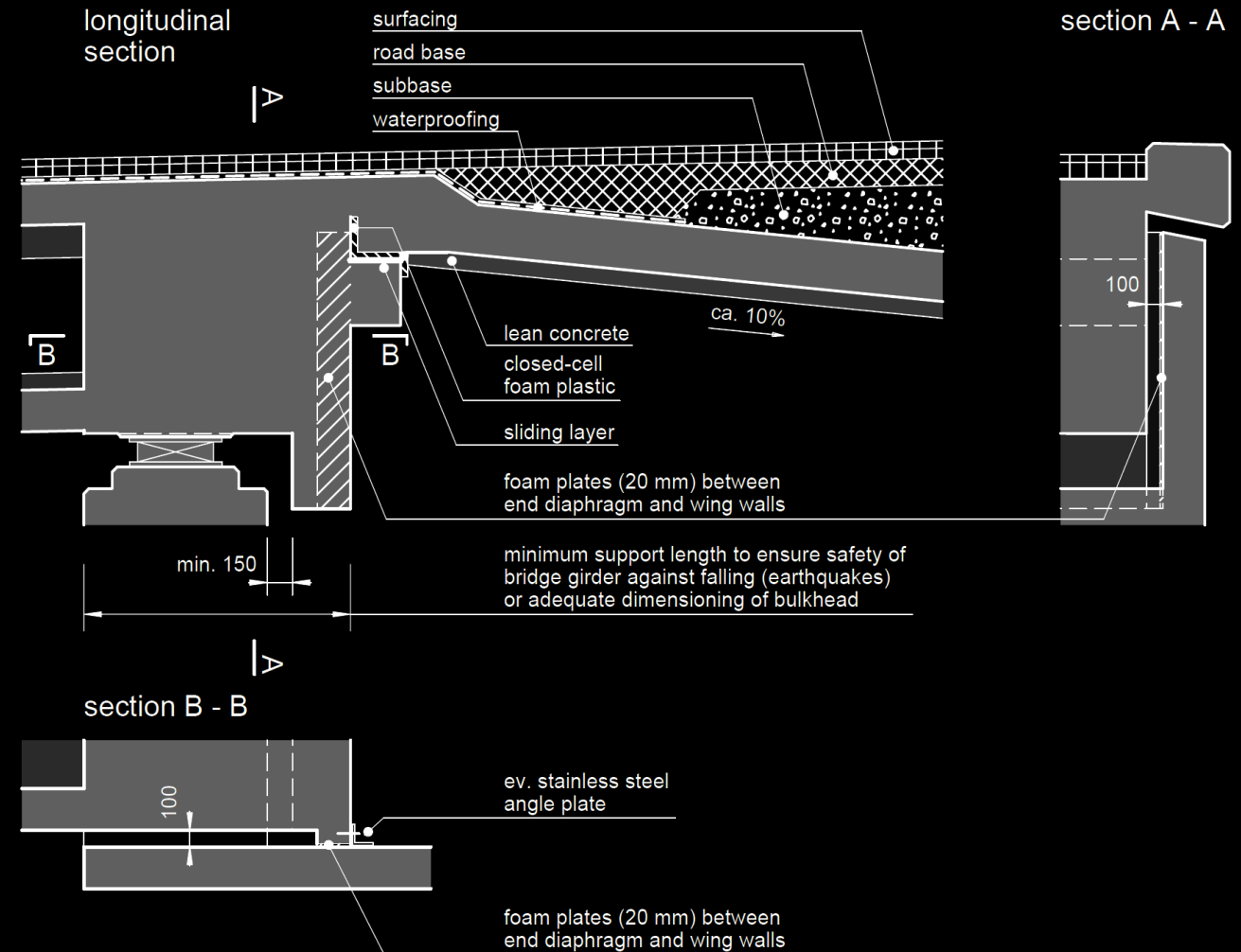



Substructure – Abutments: Classification / Examples

As already mentioned (in this chapter, as well as the support and articulation chapter), the **design of abutments differs strongly**, depending on the **local / regional preferences** of clients and designers. This slide shows a solution frequently used in some countries; more examples see support and articulation (integral abutments).

Retained earth (this slide) can be used for abutments walls, with the same advantages and drawbacks as in other retained earth walls:

- **efficient system for tall approach embankments**
 - ... use backfill as retaining wall
 - ... symmetric embankments: reinforcement fixed to facings at both ends
- **appearance may be unsatisfactory (untidy)**
- **durability concerns**
 - ... steel reinforcement: corrosion
 - ... geosynthetic reinforcement: degradation
- **construction process**
 - ... compaction of backfill without damaging reinforcement

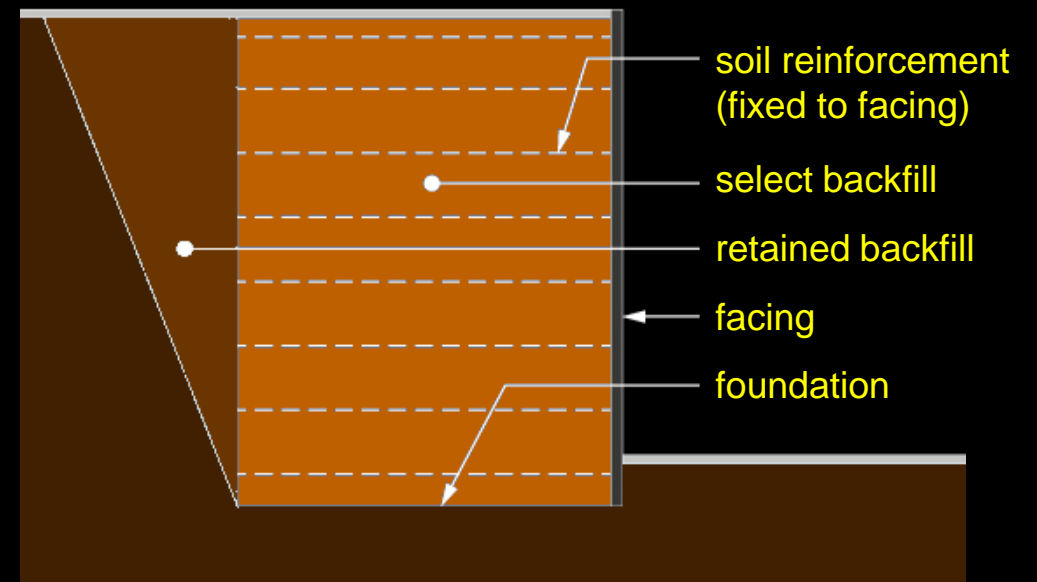

Substructure – Abutments: Classification / Examples

Other materials than concrete may of course be used for abutments and piers, as illustrated on the slide for **timber** and **steel**, but these are exceptions.



Substructure

Abutments – Design

Substructure – Abutments: Dimensioning

Jointed **abutments** are essentially **retaining walls**, retaining backfill and approach embankment **longitudinally**.

As such, they have to be designed for **ULS and SLS** as **structural elements**, but also **geotechnically**, against

- **Bearing** (Grundbruch)
- **Sliding** (Gleiten)
- **Toppling (US: Turnover)** (Kippen)

Unless a pile foundation is required, the abutments act as **gravity walls** loaded by:

- **Earth pressures from embankment / backfill** $e_a \dots e_0, e_p$
- **Earth pressure due to traffic load on embankment** $e_a(q)$ or **traffic load + braking force** (see notes)
- **Vertical girder support reaction** R_z
- **Horizontal support reactions** R_x, R_y
- **Abutment self-weight** G
- **Further loads**

Geotechnical design see **lectures of IGT** (and particularities, next slide)

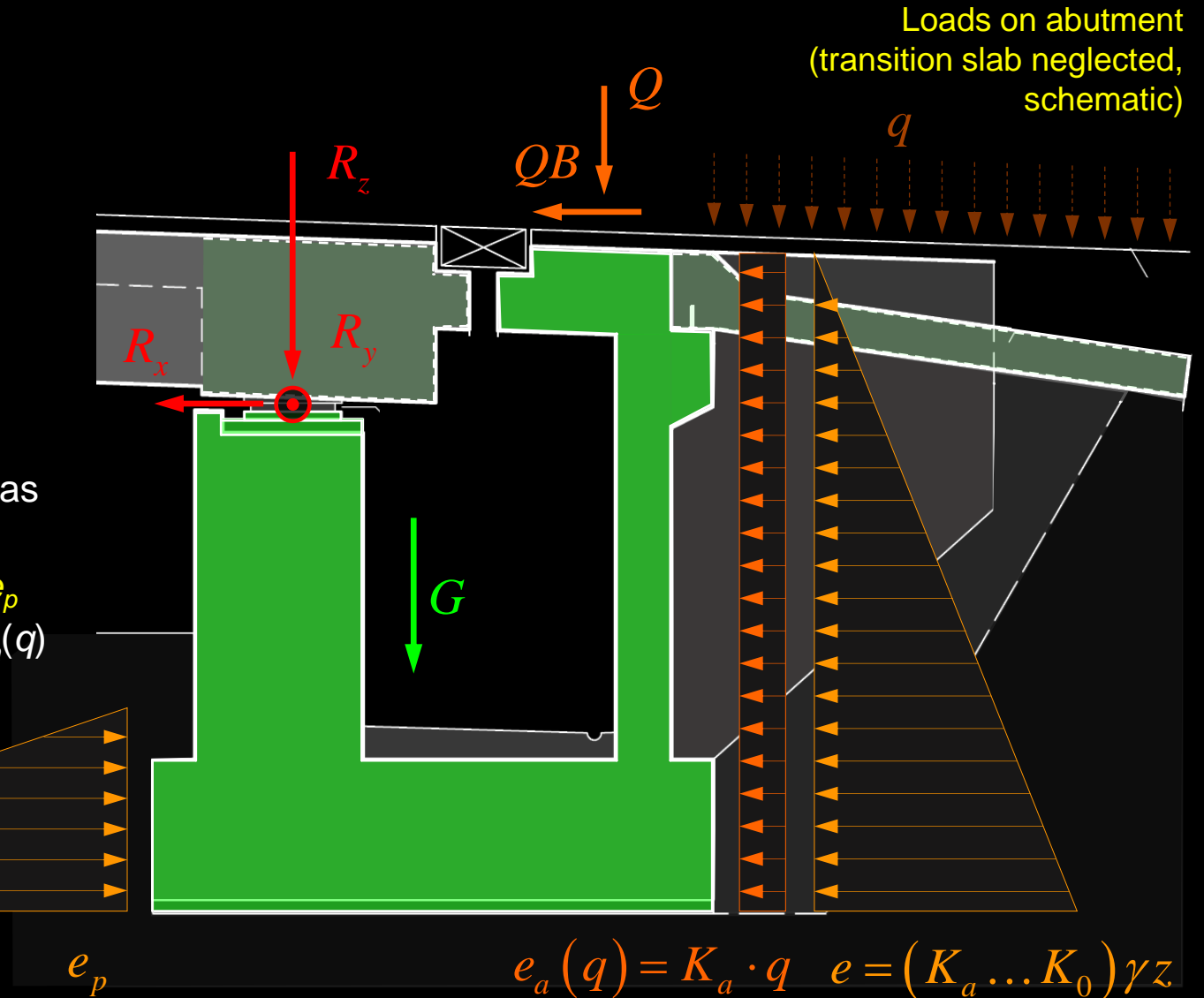

Substructure – Abutments: Dimensioning

The following particularities should be observed:

- Usually, earth pressures on the **active side** are higher than active pressure; $(K_a + K_0)/2$ often is assumed
- **Earth pressure due to traffic loads** may be approximated by assuming a **uniform vertical load**, e.g. $q_k = 25 \text{ kPa}$, on the entire approach embankment ($\rightarrow e_{ak}(q) \approx 10 \text{ kPa}$)
- **Wall friction** (not shown in the figure) may be assumed where appropriate $(0.5 \dots 0.67) \cdot \varphi$
- No **water pressure** is usually assumed since drainage mats and seepage pipes are provided (\rightarrow maintenance, flushable!)



Seepage pipe at abutment base

Observe clean gravel and geotextile (to be unrolled and put around gravel before backfilling)

Drainage mats

Fixed to walls before backfilling)



Substructure – Abutments: Dimensioning

The following particularities should be observed:

- **Longitudinal support reactions** are caused by (figure):
 - ... **horizontal loads H_d** (braking, wind, seismic, etc.) acting on **girder, piers and abutment**
 - ... **restraint to girder contraction** (or expansion), as illustrated in the figure (see section on pier design for more detailed information on values)
 - **design fixed abutment** providing longitudinal restraint **to resist reaction $R_{x,A2}$**
 - design abutment with longitudinally movable bearings to resist frictional force $\mu \cdot R_{z,A2}$
 - design piers depending on connection to girder (force or imposed pier head deformation), see section on piers

Horizontal support reactions are limited to the **bearing friction** in case of movable bearings.

Piers with hinges at both ends (pin-jointed members) also generate horizontal forces (see piers, system stability)

Movements due to girder contraction (schematic, horizontal fixity at right abutment A2)

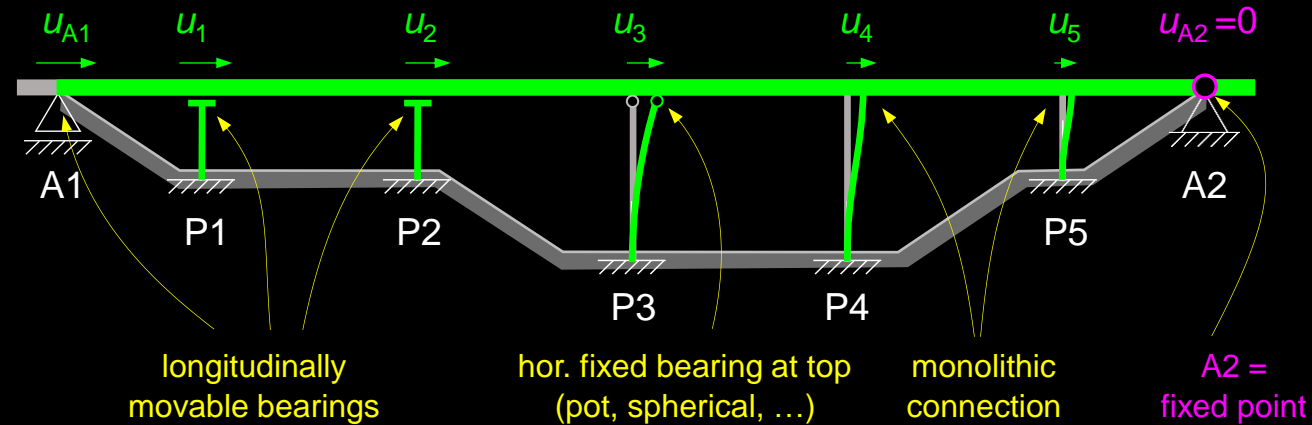

Loads on girder

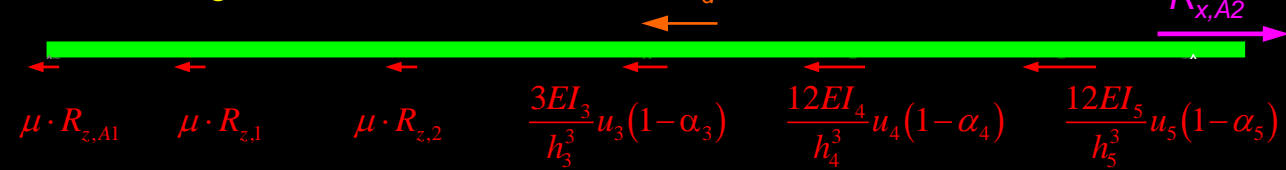

bearing friction forces, for concomitant vertical reactions R_v (or horizontal forces of elastomeric bearings)

horizontal forces at top of pier (in this example: all piers assumed to be fixed at bottom, P3 hinged at top, P4+P5 fixed at top)

Substructure – Abutments: Dimensioning

In jointed and integral abutments, the **wing walls** retain the backfill and approach embankment in the **transverse** direction. They may be designed

- as **gravity walls** (monolithically connected to the abutment walls or independent) or
- actual “**wings**”, i.e., acting as slabs **horizontally cantilevering** from the abutment walls

Integral and semi-integral abutments and their behaviour were already presented in the section on support and articulation.

Cantilever wing walls may easily be dimensioned using a slab analysis software, modelling the wings and the front wall as one slab with line supports along the connecting edges



Substructure – Abutments: Dimensioning

Transition slabs (Schleppplatten) are commonly provided in road bridges to **accommodate horizontal and vertical relative displacements** between bridge end and embankment; in railway bridges with ballasted tracks, a backfill with stabilised material is often used instead.

Transition slabs may be positioned directly under the pavement (usual e.g. in US), or buried underneath the subbase of the road. In either case, they should **ensure a smooth ride**, which requires a certain length depending on the **expected differential settlement** (lower figure). In CH, the following angles are considered:

- $\alpha \leq 0.4 \%$ for motorways ($v=120$ km/h)
(required length usually ca. 5...8 m)
- $\alpha \leq 0.8 \%$ for other roads ($v \leq 80$ km/h)
(required length usually ca. 3...5 m)

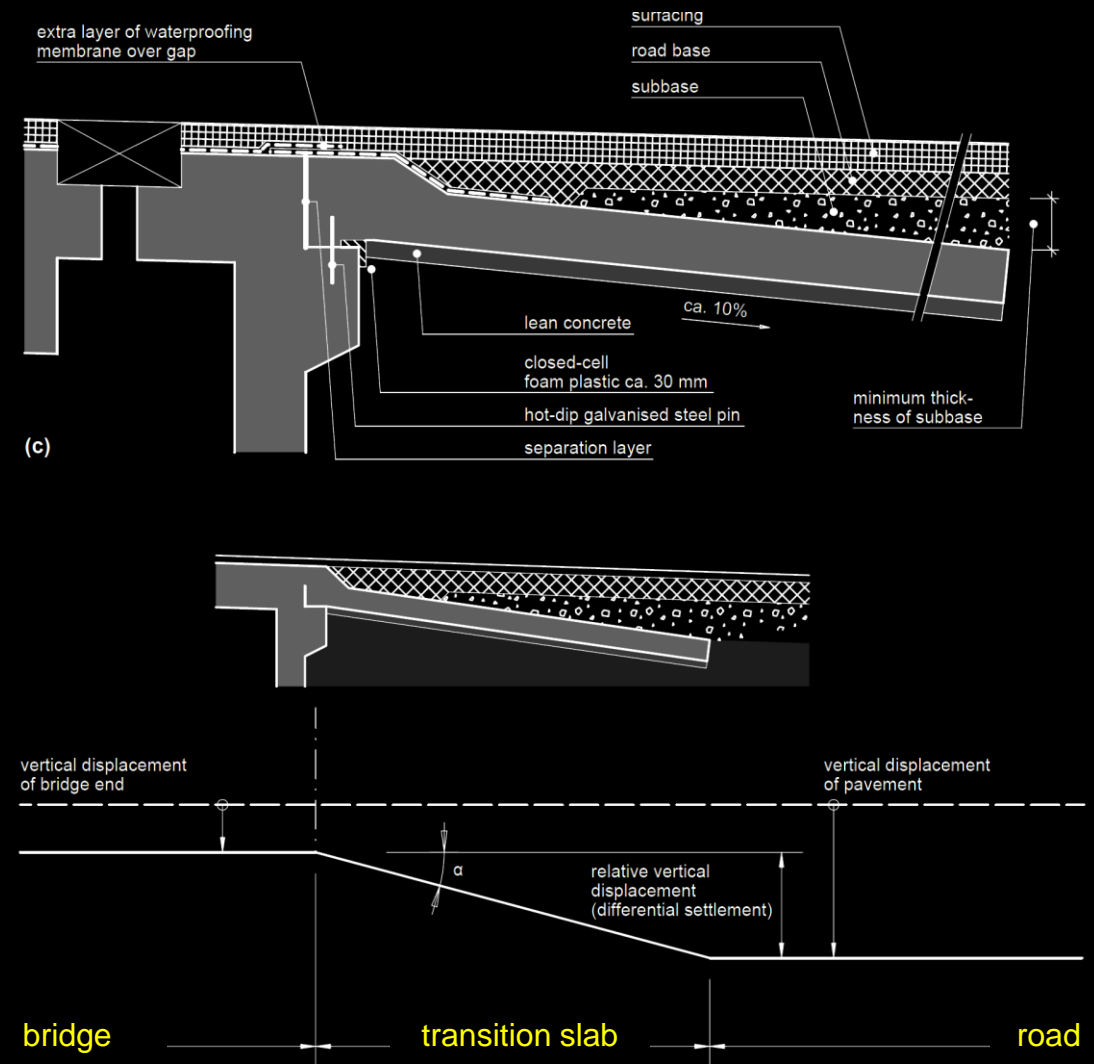

Substructure – Abutments: Dimensioning

Most previous slides illustrate **jointed abutments** accommodating horizontal movements of the bridge end with minimal restraint.

Integral and semi-integral abutments and their behaviour were presented in the section on support and articulation. In addition to the benefits of integral abutments mentioned there, i.e.

- **lower** construction and maintenance **costs**
- less restricted **ratios** of **side span / interior span**
- **longer** or more **slender end spans** possible
- **noise reduction** and enhanced **user comfort**
- structural **redundancy**

they have the advantage that in many cases (particularly in frame bridges) the **earth pressure on the abutments at both bridge ends** can be shortcut, which is **highly beneficial** for the foundation design. This compensates the higher bending moments in the abutment walls due to strain ratcheting (increased earth pressure, see integral bridges).

Jointed abutment

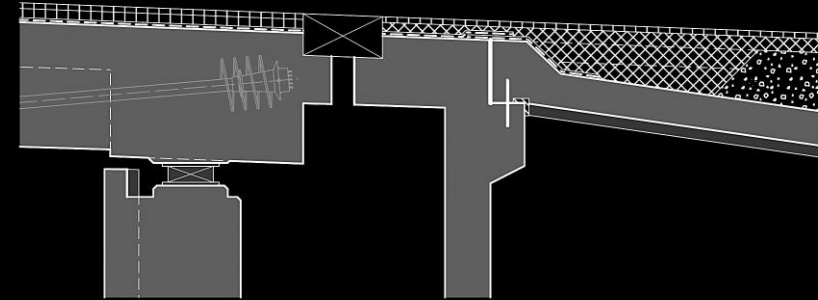

Integral abutment (much simpler)

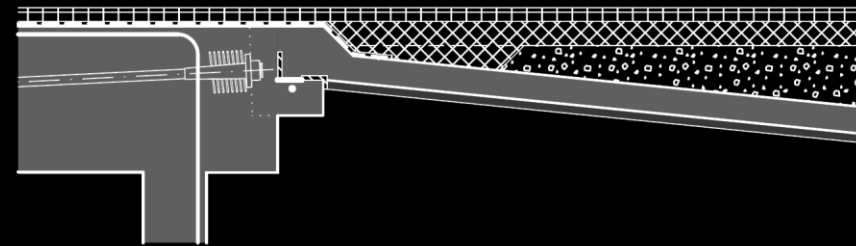

Earth pressure transfer in closed frame bridge (underpass)

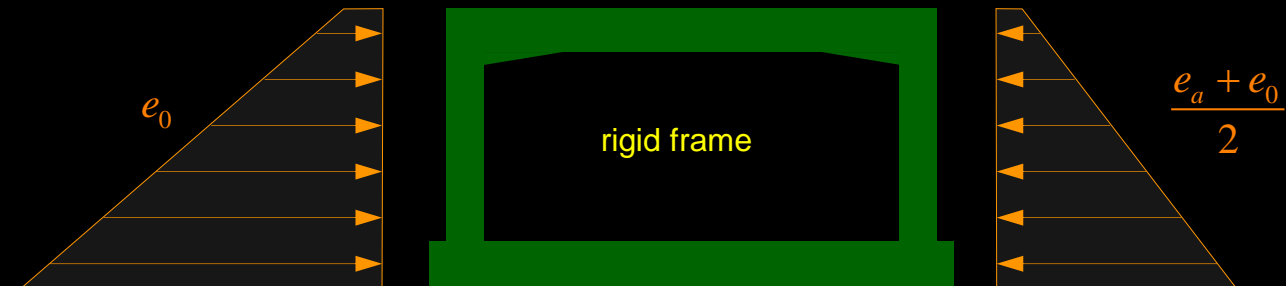

Substructure – Abutments: Dimensioning

Most previous slides illustrate **jointed abutments** accommodating horizontal movements of the bridge end with minimal restraint.

Integral and semi-integral abutments and their behaviour were presented in the section on support and articulation. In addition to the benefits of integral abutments mentioned there, i.e.

- **lower** construction and maintenance **costs**
- less restricted **ratios** of **side span / interior span**
- **longer** or more **slender end spans** possible
- **noise reduction** and enhanced **user comfort**
- structural **redundancy**

they have the advantage that in many cases (particularly in frame bridges) the **earth pressure on the abutments at both bridge ends** can be shortcut, which is **highly beneficial** for the foundation design. This compensates the higher bending moments in the abutment walls due to strain ratcheting (increased earth pressure, see integral bridges).

Jointed abutment

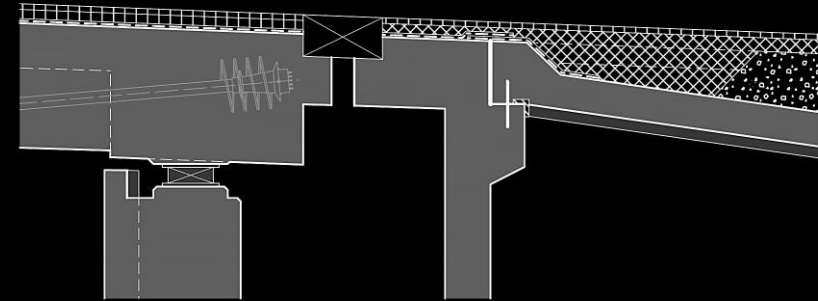

Integral abutment (much simpler)

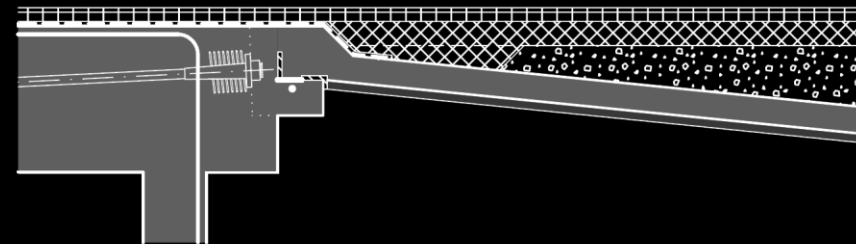

Earth pressure transfer in closed frame bridge (underpass)

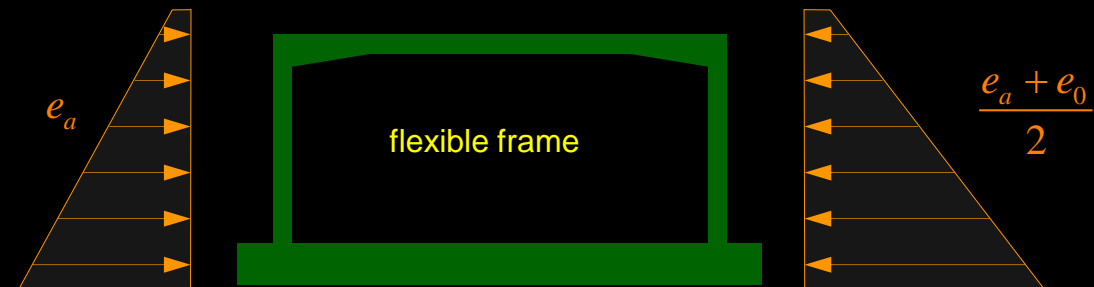

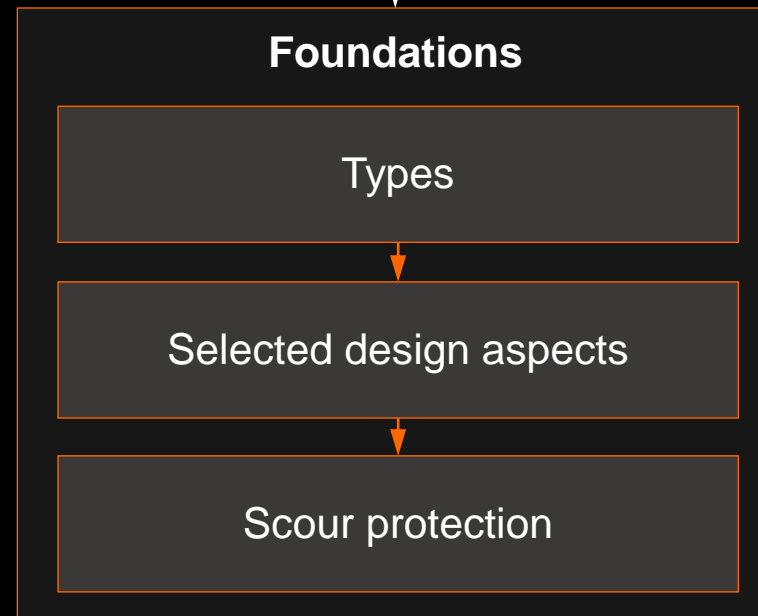
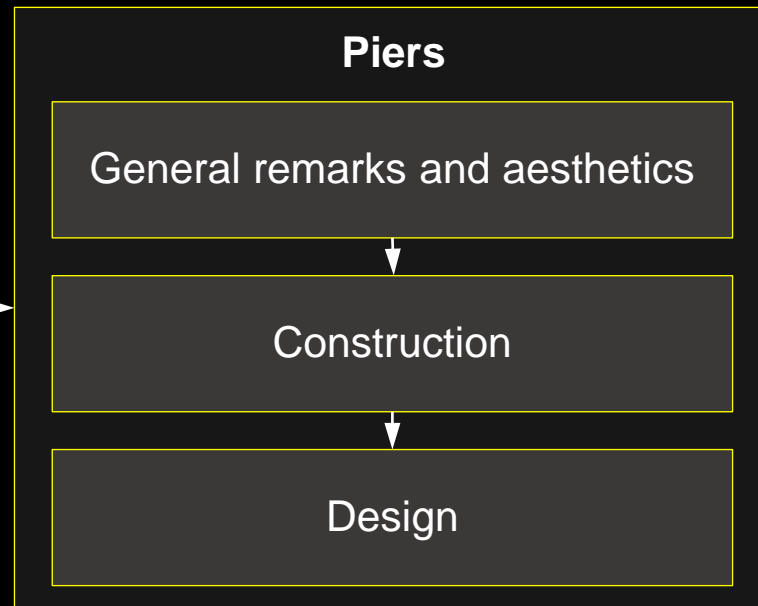
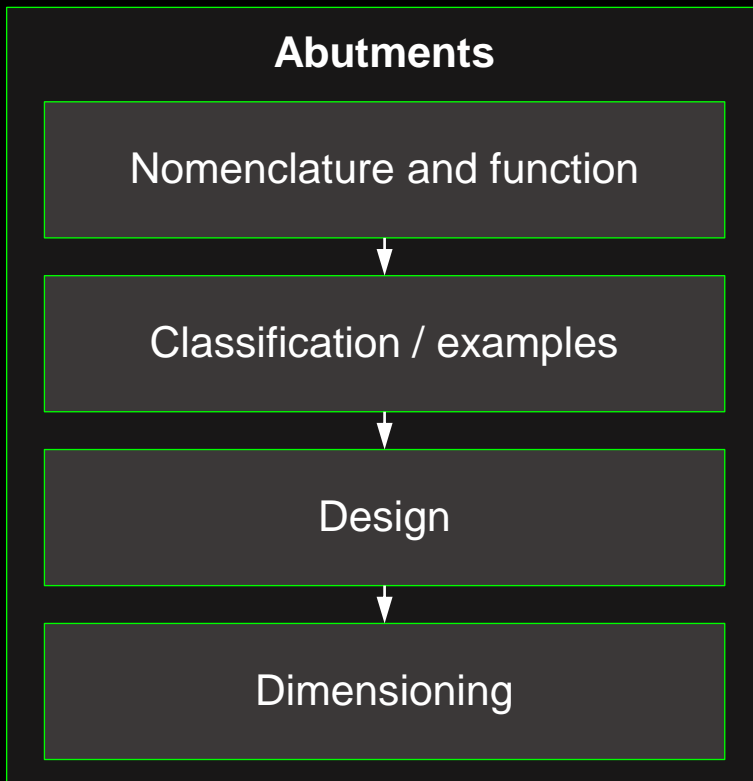

Substructure

Piers – General remarks and aesthetics

Substructure – Piers: General remarks and aesthetics

Bridge piers support the bridge girder. They provide

- vertical support (always)
- horizontal support in transverse direction (usually)
- torsional support (often)
- horizontal support in longitudinal direction (sometimes)
- longitudinal moment “support” (if monolithically connected; piers are usually much more flexible $\rightarrow \Delta M_y$ small)
- support against rotations around the vertical axis (rarely, may be required during construction (free cantilevering))

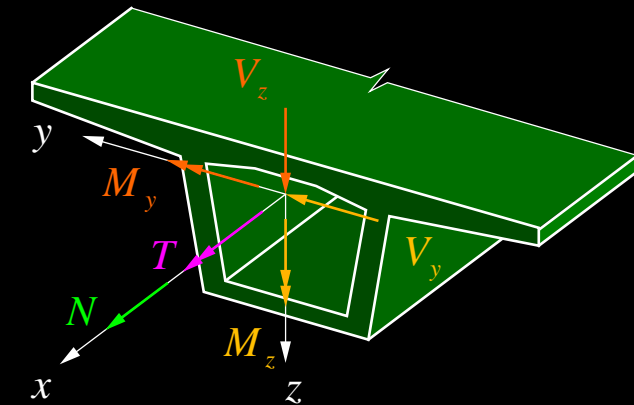

	monolithic	○	○	○	○	○	○
ΔV_z	✓	✓	✓	✓	✓	✓	✓
ΔV_y	✓	✓	✓	—	✓	✓	—
ΔT	✓	✓	✓	✓	—	—	—
ΔN	✓	✓	—	—	✓	—	—
ΔM_y	(✓)	—	—	—	—	—	—
ΔM_z	✓	—	—	—	—	—	—

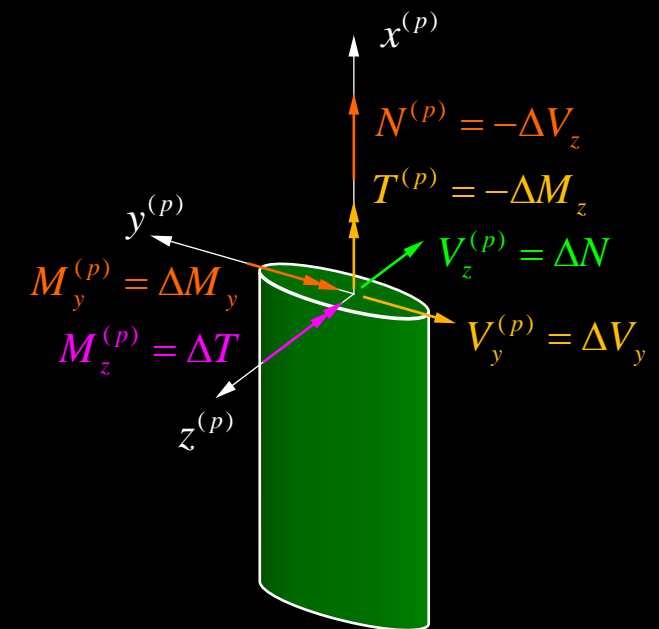

Substructure – Piers: General remarks and aesthetics

The piers are often decisive for the aesthetic quality and site integration of a bridge

- selection of pier layout (single, double) highly relevant
- design of pier geometry important



Substructure – Piers: General remarks and aesthetics

Pier Layout

As already outlined (see Superstructure – Aesthetics):

- Piers are decisive for the transparency of a bridge
- Transparency of the piers depends highly on the perspective (direction of sight), particularly for wide piers
- Single, narrow piers (one slender pier per support axis) are much more transparent than wide or twin piers

Furthermore, single piers have a smaller footprint, which may be decisive for an economical span layout and the future use of the space below the bridge (urban bridges, skew crossing of roads or railway lines).

- Avoid wide piers (including hammerhead columns and multiple-column bents)
- Provide single, slender piers where possible

See examples on this and following slides.



Substructure – Piers: General remarks and aesthetics



Substructure – Piers: General remarks and aesthetics

Single, slender piers are feasible (see Support and Articulation)

- in narrow bridges
- in medium width bridges if the piers provide neither horizontal nor torsional support to the girder (single longitudinal girder with high torsional stiffness and strength required)

In other cases, larger pier widths or twin piers are required.

Except for wide, low bridges (see behind), single piers are still preferred. The pier width should be limited to maximise transparency; usually, the piers should not be wider than about 25...35% of the deck width.

Twin piers, even if they are slender and well designed, risk to be perceived as perturbing or even disordered if the span is not clearly larger than the transverse spacing.



Substructure – Piers: General remarks and aesthetics



Substructure – Piers: General remarks and aesthetics

However, in wide low bridges, to maximise the apparent slenderness (girder depth vs. clear height under the bridge), twin piers are often adequate.

Twin piers are usually also required in twin girder bridges (next slide).



Substructure – Piers: General remarks and aesthetics



Substructure – Piers: General remarks and aesthetics

Pier geometry – Orientation in plan and dimensions

Piers resisting **horizontal transverse forces**, and/or providing **torsional support** to the girder **require a substantial width** of about 25...35% of the deck width (transverse to girder axis).

Longitudinally, piers may be much **more slender** if they do not have to longitudinally stabilise the girder. If **bearings** are provided on the top of piers, these are often **decisive for the minimum pier thickness**.

Aesthetically, the piers should be slender to **maximise transparency**, but at the same **convey a perception of stability**.

Rectangular, prismatic single piers are the obvious option to satisfy these requirements. However, in many cases, somewhat more refined geometries are adequate:

- **Increasing width** towards bottom (in high piers for stability, in low piers to foster the perception of stability)
- **Rounded or elliptical cross-sections** (more slender appearance, particularly adequate if pier orientation varies and for hydraulic reasons in river piers)
- **Circular cylindrical** piers (lack orientation, which may be disconcerting but adequate for twin piers).



Substructure – Piers: General remarks and aesthetics

Pier geometry – General observations

Refined pier geometries are feasible with little effect on cost since piers constitute <10% of total cost for moderate bridge heights.

Economy is thus no reason to design dull prismatic piers with rectangular cross-section – but there may be functional or aesthetic reasons why they are appropriate for a specific site.

In order to facilitate economical formwork fabrication, pier geometries should however (see notes for definition) be

- **prismatic** (constant section)
(simple and economical, even for curved sections)
- **polyhedral** (polygonal faces with straight edges)
(more complex)
- consist of **developable** (complex) or even **ruled surfaces**
(most complex)

Complex geometries should only be used for high piers, or if the same formwork can be used for several piers.

Doubly curved formworks other than ruled surfaces are an order of magnitude more expensive and should be avoided.



Substructure – Piers: General remarks and aesthetics

Pier geometry – General observations

Refined pier geometries are feasible with little effect on cost since piers constitute <10% of total cost for moderate bridge heights.

Economy is thus no reason to design dull prismatic piers with rectangular cross-section – but there may be functional or aesthetic reasons why they are appropriate for a specific site.

In order to facilitate economical formwork fabrication, pier geometries should however (see notes for definition) be

- **prismatic** (constant section)
(simple and economical, even for curved sections)
- **polyhedral** (polygonal faces with straight edges)
(more complex)
- consist of **developable** (complex) or even **ruled surfaces**
(most complex)

Complex geometries should only be used for high piers, or if the same formwork can be used for several piers.

Doubly curved formworks other than ruled surfaces are an order of magnitude more expensive and should be avoided.

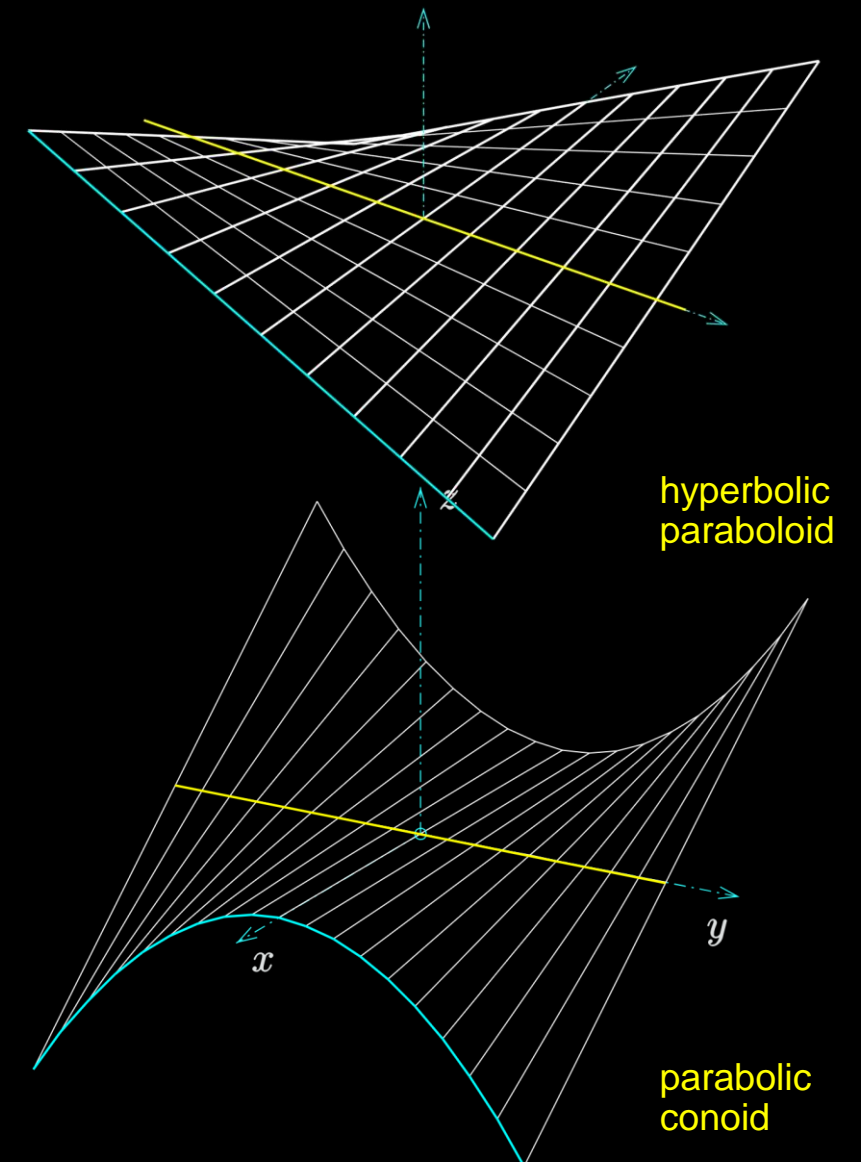

Substructure – Piers: General remarks and aesthetics

Pier geometry – Prismatic piers

Prismatic piers adapt to variable height without any particular measures and are appropriate

→ for **low-moderate height**

→ where **no particularly expressive form** is sought

Prismatic piers may be provided with **complex polygonal cross-sections** without excessive cost. **Curved cross-sections** are more expensive, but this is usually insignificant due to the low share of piers in total cost.



Substructure – Piers: General remarks and aesthetics

Pier geometry – Polyhedral piers

Polyhedral piers are less economical than prismatic piers, but enable **structurally efficient** (e.g. variable width according to bending moments in pier) and **aesthetically appealing** geometries. They are appropriate

- for **tall, slender piers** (structural efficiency)
- where a **more expressive form** is adequate

Designers and clients are often reluctant regarding polyhedral geometries for economical concerns. However, experience shows that such geometries **cause little extra cost if an efficient pier formwork** is part of the design.

In the example shown on the right and the next slide, the apparently complex geometry essentially consists of **four slightly inclined planes** (same formwork panels used for full height of pier), cut off laterally by variable end pieces. The pier was cast using a formwork corresponding largely to the concept proposed in the design competition already (climbform, 14 segments @ 4.50 m, vertical precamber 30 mm).

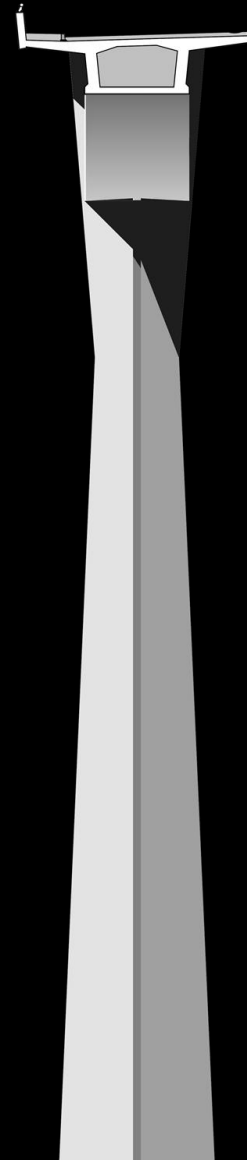

Substructure – Piers: General remarks and aesthetics



cardboard model used in conceptual design

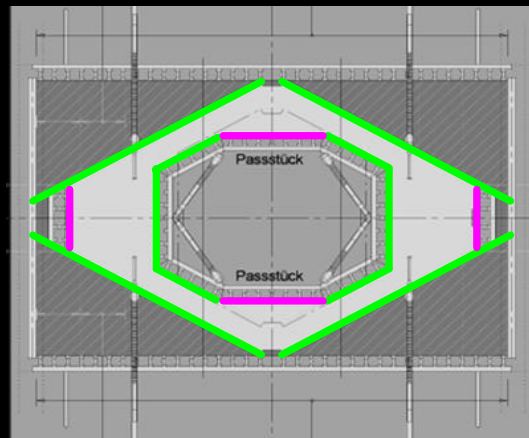

formwork panels used for full pier height

fitting panels (adjusted per segment)

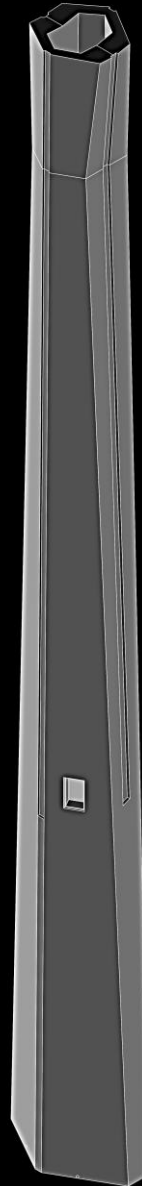

3D-model used in final design

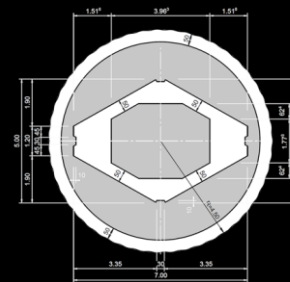
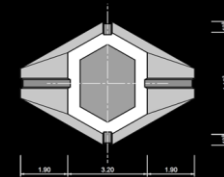
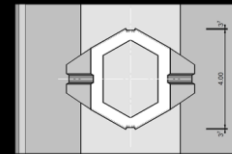
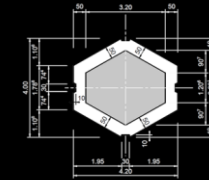

Substructure – Piers: General remarks and aesthetics

Pier geometry – Developable surfaces

Developable surfaces may be used to achieve **geometries including curved parts**. These may be unpretentious (conical, cylindrical, etc., this slide) or expressive (next slide).

Steel formwork is often used for such geometries, as thin “plates” can readily be curved uniaxially → inlays unless very smooth surface is desired.

(Note the **polyhedral soffit of the girder** → observations on pier geometry apply to girders, but economy is more relevant for girder formwork)

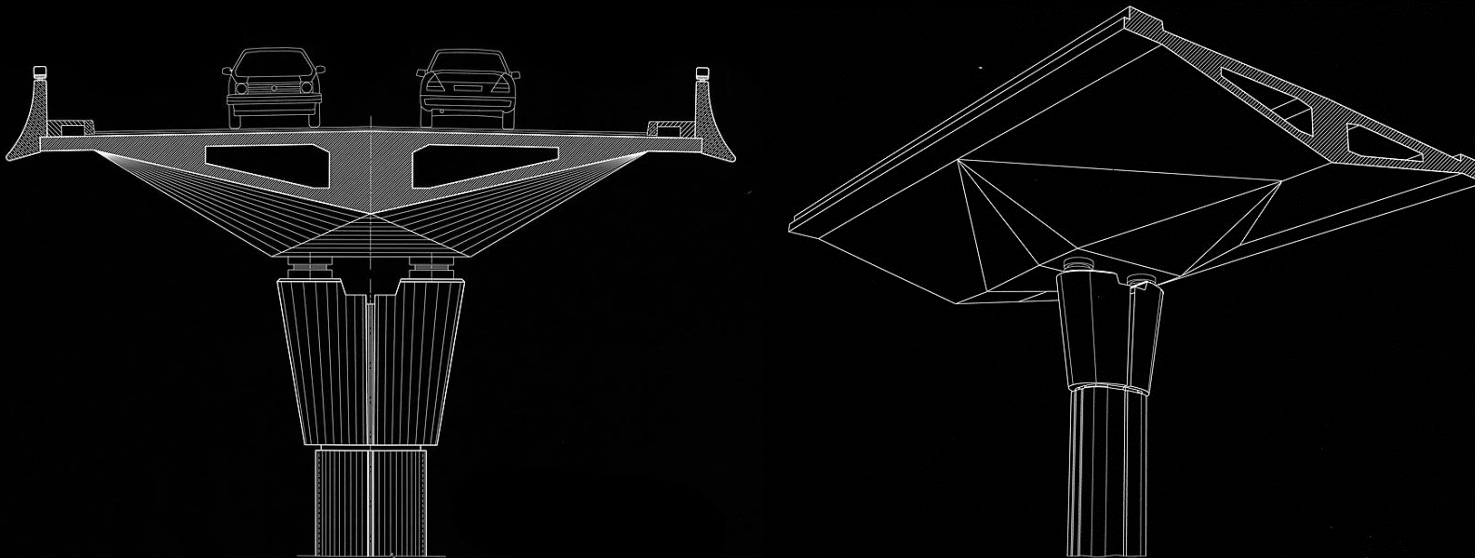

Substructure – Piers: General remarks and aesthetics

Pier geometry – Developable surfaces

Developable surfaces may be used to achieve **geometries including curved parts**. These may be unpretentious (conical, cylindrical, etc., previous slide) or expressive (this slide).

Steel formwork is often used for such geometries, as thin “plates” can readily be curved uniaxially → inlays unless very smooth surface is desired.

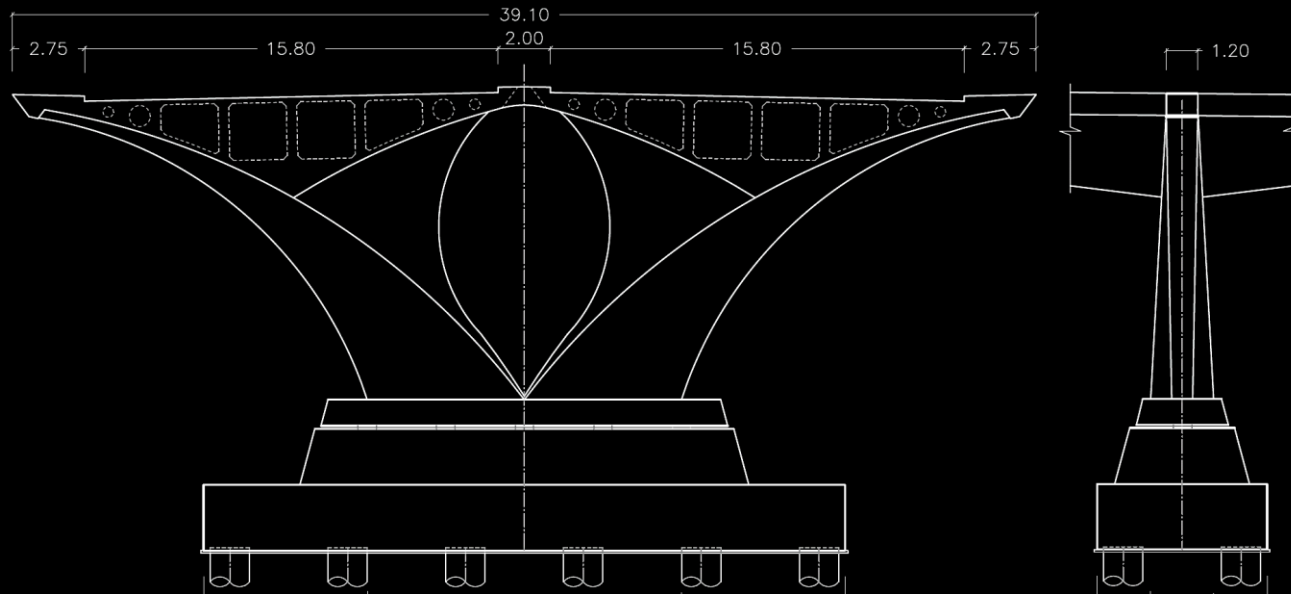

Substructure – Piers: General remarks and aesthetics

Pier geometry – Ruled surfaces

Ruled surfaces may be used to achieve expressive geometries including curved parts.

They can be produced using timber slats, making them more expensive than prismatic or polyhedral piers, yet still much less expensive than free-form double curved surfaces.

The following slide shows a girder with ruled surface geometry.

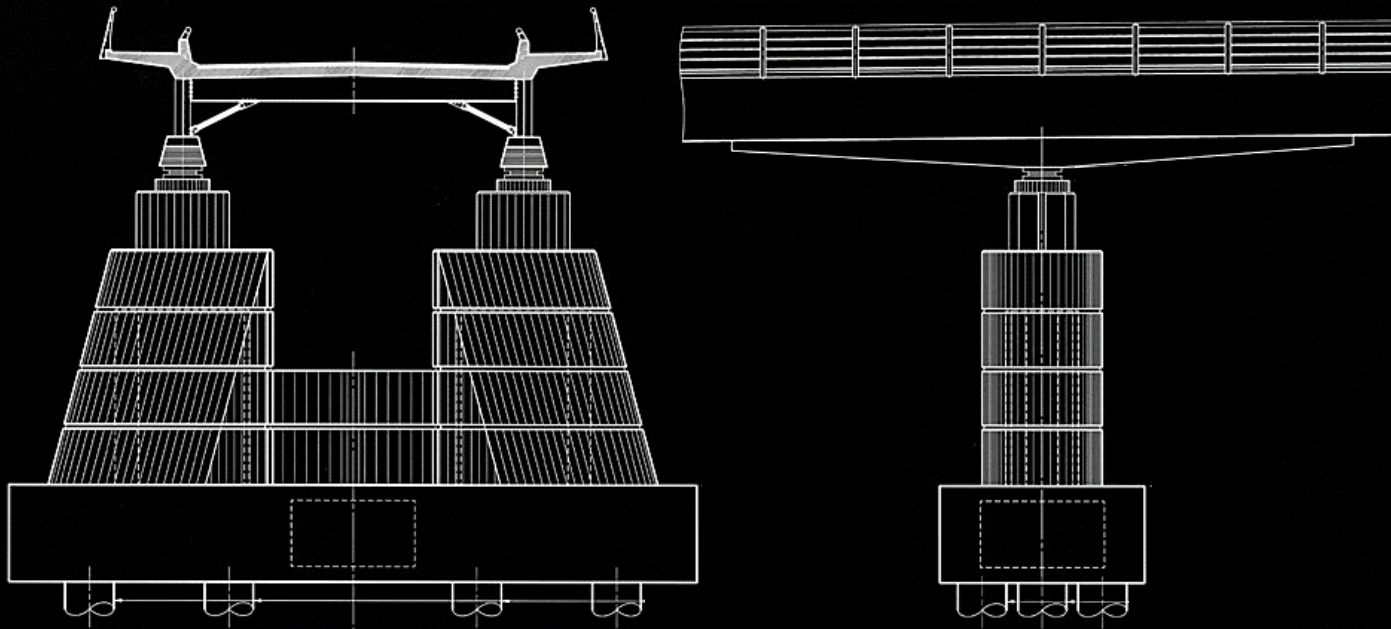

Substructure – Piers: General remarks and aesthetics



Substructure – Piers: General remarks and aesthetics

Pier geometry – Variable height

Hardly any bridge with several piers has a constant height above ground, not even in the case of road bridges across a river or lake: A longitudinal gradient is usually provided for drainage. On the other hand, the piers usually have a constant width at their top (bearings or connection to girder).

Hence, unless prismatic piers are used, finding a pier geometry that fits for the tallest as well as the shortest piers of a bridge may be challenging.

Prismatic parts at the bottom of low-medium height piers, are often useful to achieve a consistent appearance of all piers in a bridge with strongly varying height above ground, see next slides.

Alternatively / additionally, the upper part of the piers may adopt the superstructure geometry, see photo and other slides (Vulpera, Steinbach, Tortosa ...)



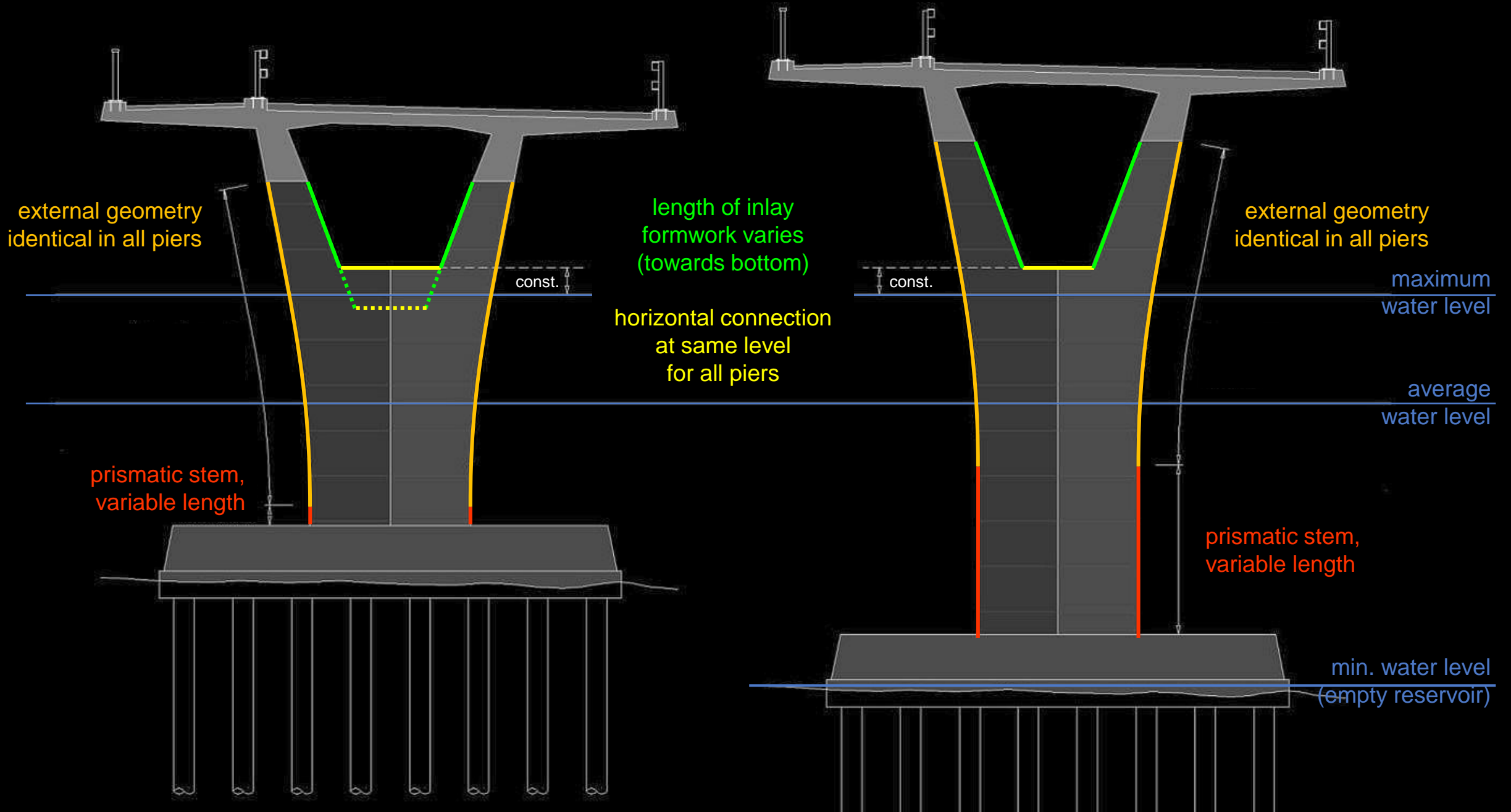

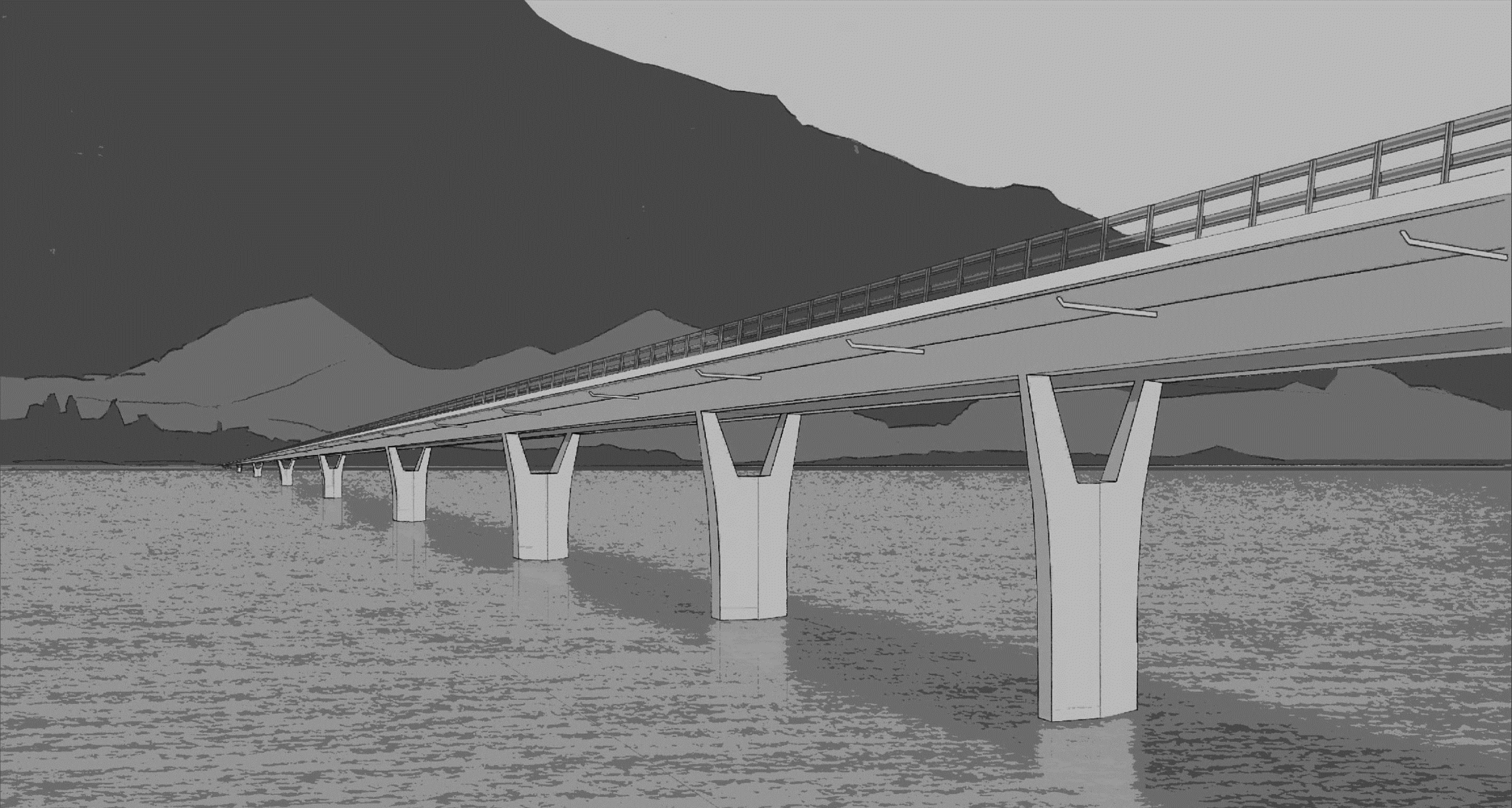



Substructure

Piers – Construction

Substructure – Piers: Construction

Pier geometry – Mechanised equipment

If **mechanised construction equipment** is used (launching girders, movable scaffold systems MSS etc.), the piers must be designed to enable their efficient use. In some cases, **pier diaphragms** need to be cast beforehand.

Requirements depend strongly on the specific system. If possible, the use of **underslung or lateral gantries** should be enabled (overhead gantries are more expensive).

In case of **incremental launching**, the pier heads must accommodate larger bearings and the piers be designed to resist the **frictional forces during launching** (and, where appropriate, accidental forces due to manipulation errors etc.).



Substructure – Piers: Construction

Pier geometry – Mechanised equipment

If **mechanised construction equipment** is used (launching girders, movable scaffold systems MSS etc.), the piers must be designed to enable their efficient use. In some cases, **pier diaphragms** need to be cast beforehand.

Requirements depend strongly on the specific system. If possible, the use of **underslung or lateral gantries** should be enabled (overhead gantries are more expensive).

In case of **incremental launching**, the pier heads must accommodate larger bearings and the piers be designed to resist the **frictional forces during launching** (and, where appropriate, accidental forces due to manipulation errors etc.).

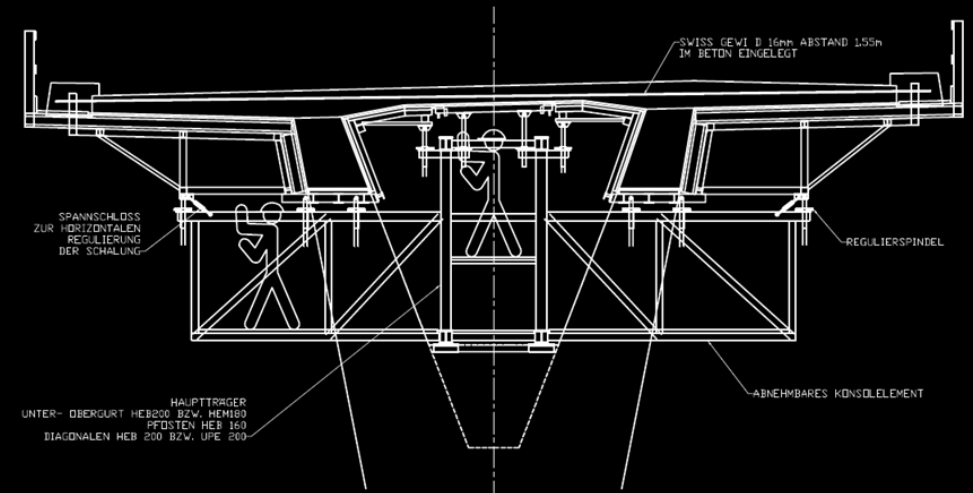

Substructure – Piers: Construction

Pier construction methods

Prismatic piers can be built very efficiently using **climbforms (Kletterschalung)**:

- segments of usually about 4...6 m height
- formwork / scaffold is fixed to the previously cast pier segment
- lifting of formwork with crane or hydraulic device (self-climbing)

Polyhedral and developable surfaces can also be built using climbforms, provided that the geometry is defined appropriately (see previous slides, Innbrücke Vulpera).

One lift per week can usually be achieved; cycles of 3 days (for 4 m lifts) are possible in perfect conditions. If short cycles are used, **curing of the concrete** requires additional measures (protect one segment below the climbform from evaporation)



Substructure – Piers: Construction



Substructure – Piers: Construction

Pier construction methods

Large and tall **prismatic piers** may alternatively be built by **slipforming (Gleitschalung)**:

- short formwork, ca. 1.2 m high, advancing continuously 24hx7d
- supported by cast-in vertical bars, extended as slipform moves
- casting speed 5-7 m per day (20...30 cm/h)

However, slipforming is only economical for **very tall piers with large cross-section** (specialist (sub-)contractor required. Furthermore, 24/7 work is difficult / prohibited (noise emissions, concrete delivery, ...) → hardly ever used today for bridge piers

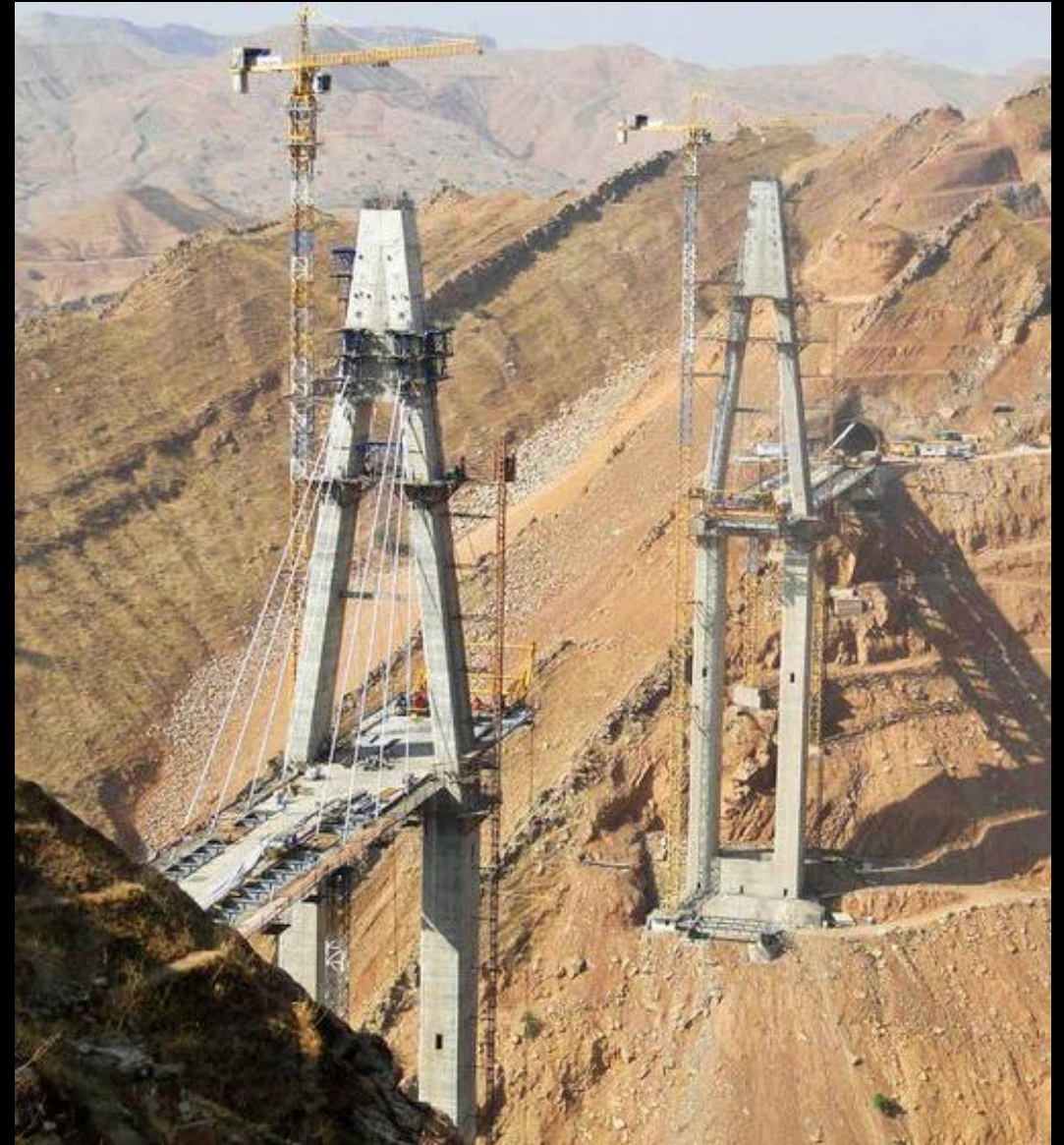

Substructure – Piers: Construction

Pier geometry – Solid or hollow cross-section

Piers with a **solid cross-section** are much simpler to build than **hollow piers**, requiring an inner formwork.

Saving weight is less relevant in vertical piers than in girders, since no bending moments are caused by the pier dead load and higher vertical loads may even be favourable for spread footing foundations.

However, hollow cross-sections have a **higher decompression moment** under a given vertical load (superstructure is usually dominant), see “Strategies for efficient bridge girders”), which is favourable for the stiffness

→ use **hollow cross-section** for tall, slender piers

$$h = 128.59 \\ (4.59 + 32 \cdot 4.00)$$

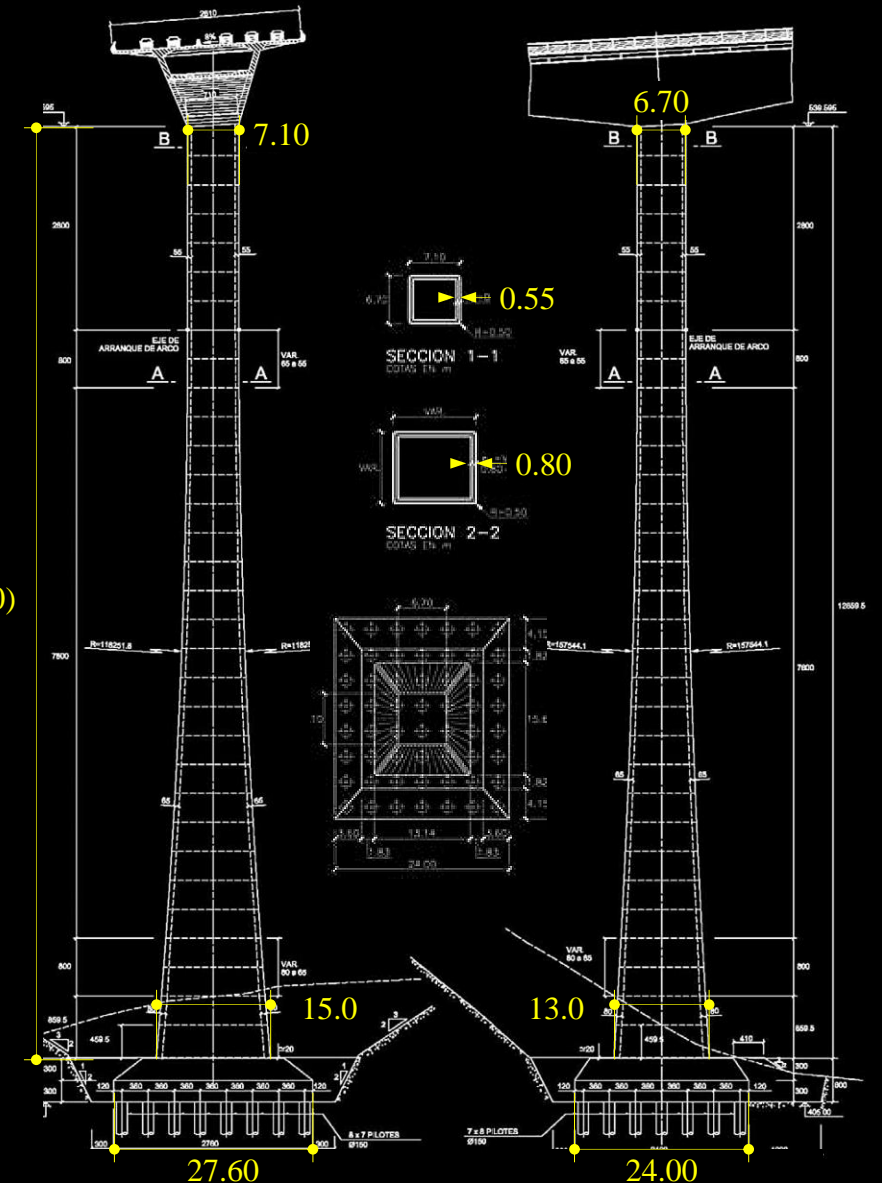

Substructure

Piers – Design

Abutments

Nomenclature and function



Classification / examples



Design



Dimensioning



Piers

General remarks and aesthetics



Construction



Design



Foundations

Types



Selected design aspects



Scour protection

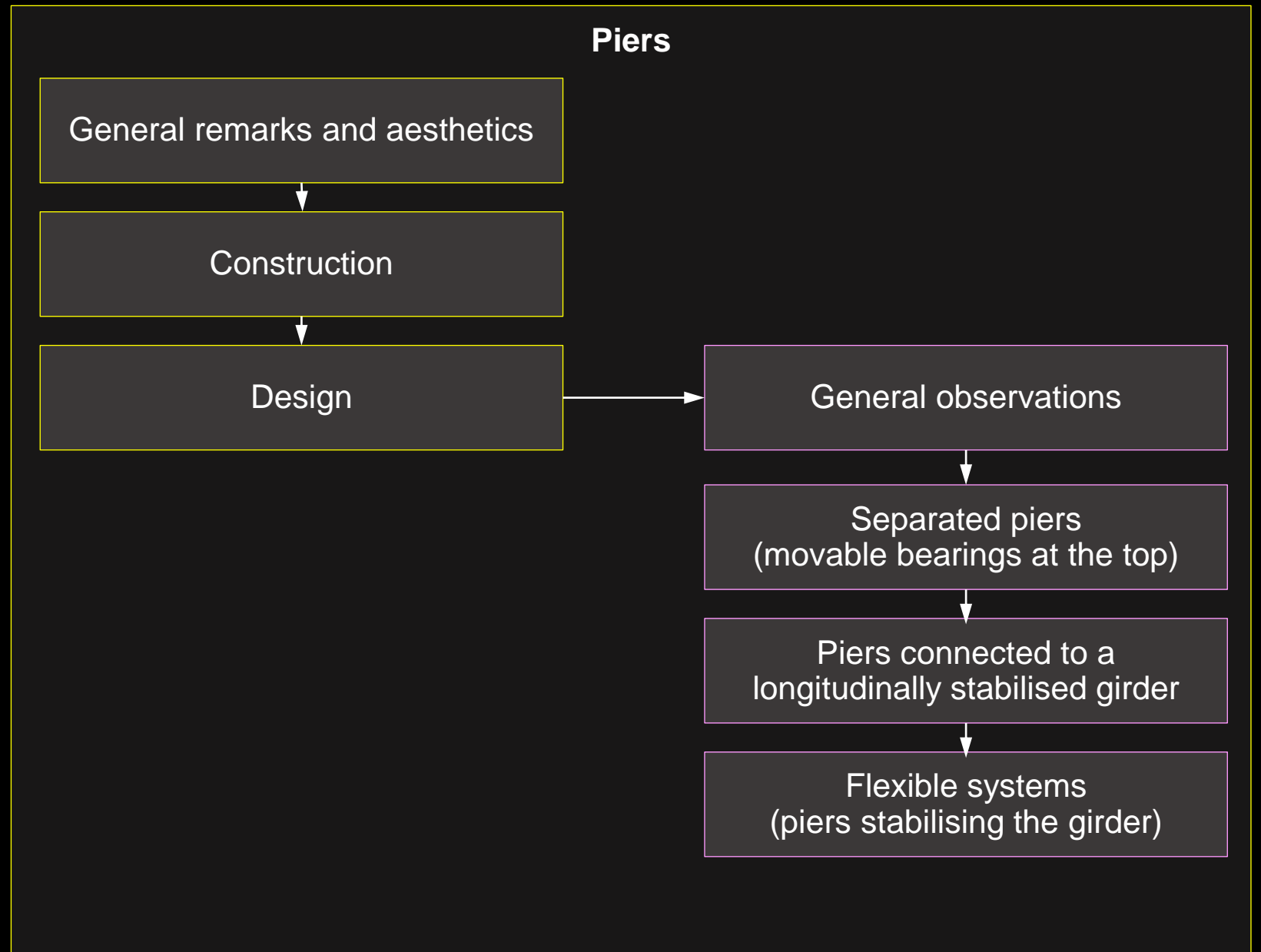

Substructure

Piers – Design General observations

Substructure – Piers: Design / General observations

Internal actions on bridge piers

- Bridge piers provide **vertical support to the girder** → high compressive normal forces
- Due to the movements of the bridge girder, **horizontal displacements** and corresponding loads are **imposed to the piers at their top** unless longitudinally movable bearings are provided
- Bending moments in bridge piers are caused by
 - **horizontal loads applied at the top** (bearing friction if provided with sliding bearings, horizontal forces transferred from deck otherwise)
 - **horizontal loads applied to the pier shaft** (wind, impact, seismic) (variable over height generally)
 - **second order effects**
- Bridge piers are often slender (longitudinally)
 - **account for geometric second order effects** when determining the relevant internal actions
- The response of concrete piers is nonlinear (cracking, concrete stress-strain relationship, creep)
 - **account for material nonlinearities**

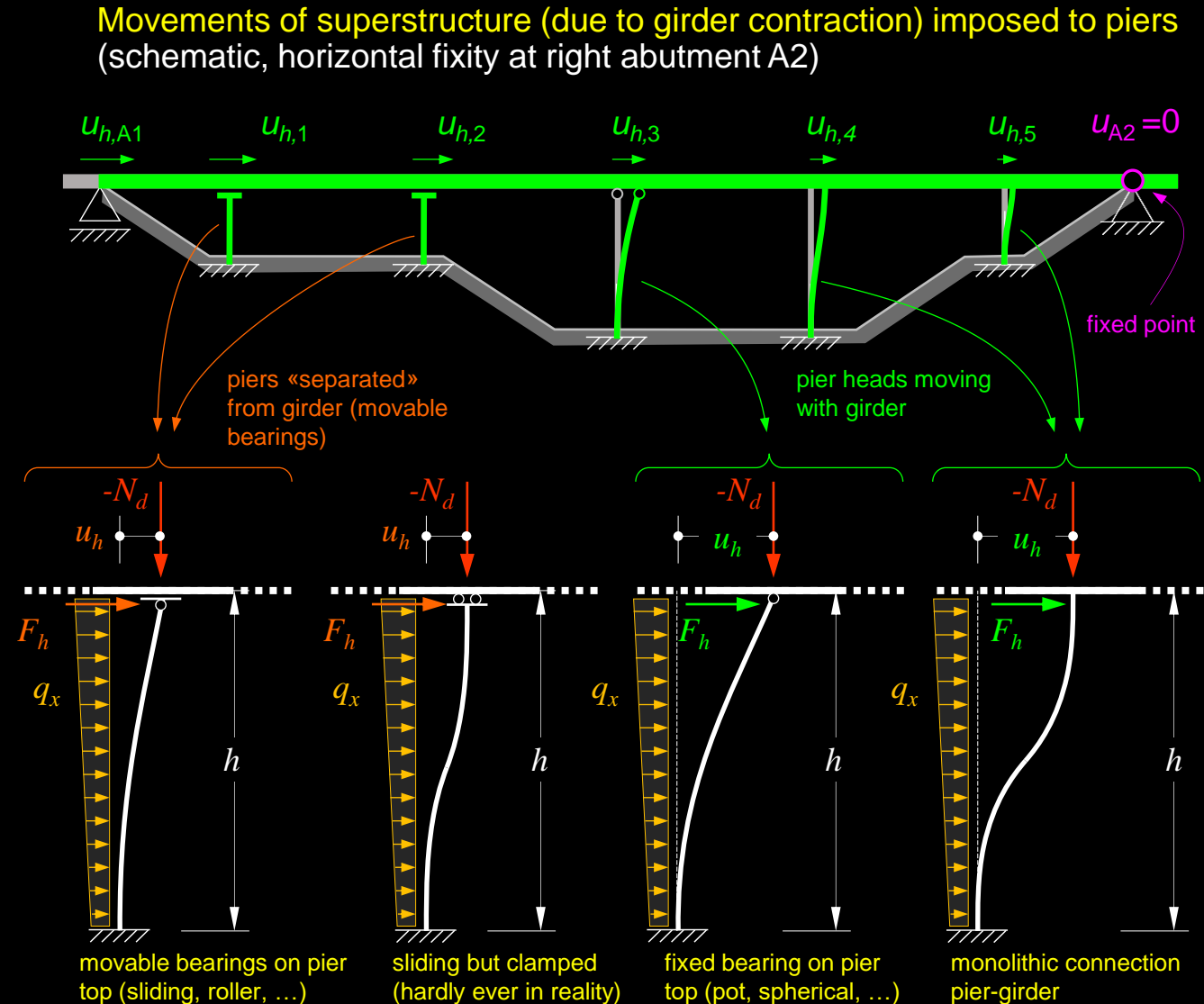

Substructure – Piers: Design / General observations

Internal actions on bridge piers and static systems

Bridge piers are generally subjected to

- **high compressive normal forces** $N < 0$, combined with biaxial bending moments M_y, M_z
 - **design for combination of $\{N, M_y, M_z\}$**
= maximum / minimum values of each action, combined with concomitant values of other actions
 - check **3D interaction diagrams** for verification (see Stahlbeton I / figure)
 - in preliminary design, check interaction of $\{M_{y,Ed}, M_{z,Ed}\}$ vs $\{M_{y,Rd}, M_{z,Rd}\}$ at $N_{Rd,min}$ and $N_{Rd,max}$

Bridge piers are typically wide, and thus much stiffer and stronger in the transverse direction than longitudinally

- design often mainly **governed by $\{N, M_y\}$** (neglect M_z in preliminary design where appropriate)

Bridge piers are often **relatively stiff compared to the foundation**; on the other hand, the girder is commonly much stiffer than the piers

- no full fixity at pier base, but clamped at top

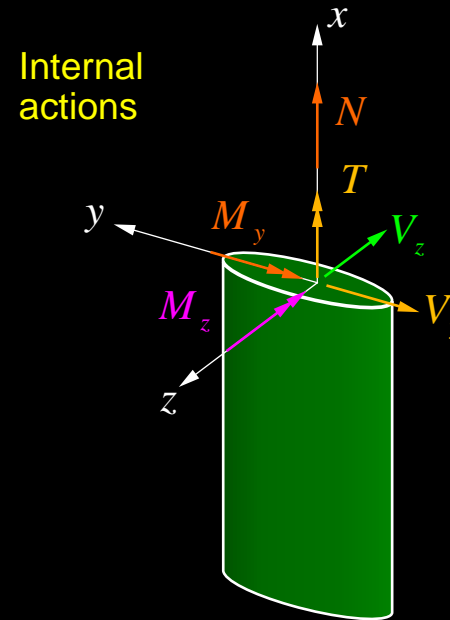

Internal actions

Cross-section resistance under $\{N, M_y, M_z\}$ 3D interaction surface

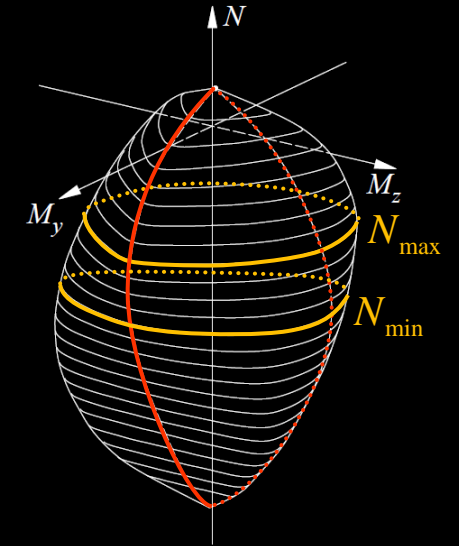

Required verifications of cross-section resistance in general case

- $\begin{Bmatrix} N_{min} \\ N_{max} \end{Bmatrix}$ with concomitant $\{M_y, M_z\}$
- $\begin{Bmatrix} M_{y,min} \\ M_{y,max} \end{Bmatrix}$ with concomitant $\{N, M_z\}$
- $\begin{Bmatrix} M_{z,min} \\ M_{z,max} \end{Bmatrix}$ with concomitant $\{N, M_y\}$

Static systems of stiff piers on soft soil

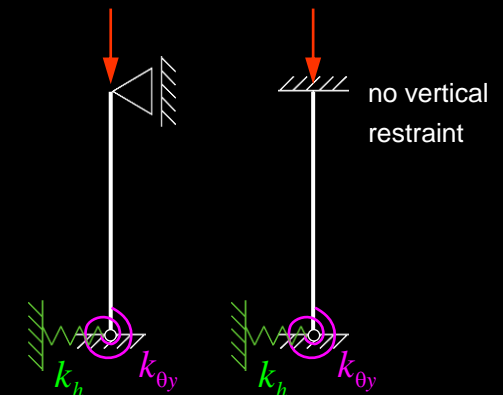

Substructure – Piers: Design / General observations

Second order analysis of reinforced concrete piers

- The pier stiffness in the 2nd-order analysis must correspond to the states of strain used to determine the resistance (interaction diagram)
- At the effective cross-section resistance M_{Rd} , large strains occur (i.e. large curvature $\chi = \text{low stiffness } EI$)
 - large deflections of (slender) piers and second-order bending moments at effective resistance
 - load when effective cross-section resistance is reached is lower than actual ultimate load
 - carry out nonlinear analysis or define nominal cross-section resistance using reduced state of strain
- Usual assumption for design: M_{Rd} limited by the onset of yielding of reinforcement ($\varepsilon_s = \pm\varepsilon_{sd} = \pm f_{sd}/E_s$):

$$\chi_d \leq \frac{\varepsilon_{sd} - \varepsilon'_{sd}}{d - d'} \rightarrow EI_d = \frac{M_{Rd}}{\chi_d} \approx M_{Rd} \cdot 230(d - d') \quad (\text{for B500B})$$

- Creep may be accounted approximately for by adding a term $\chi_{irr,d}$:

$$\chi_d \leq \frac{\varepsilon_{sd} - \varepsilon'_{sd}}{d - d'} + \chi_{irr,d} \quad \chi_{irr,d} \approx \frac{|\varepsilon_{c\infty}|}{d}$$

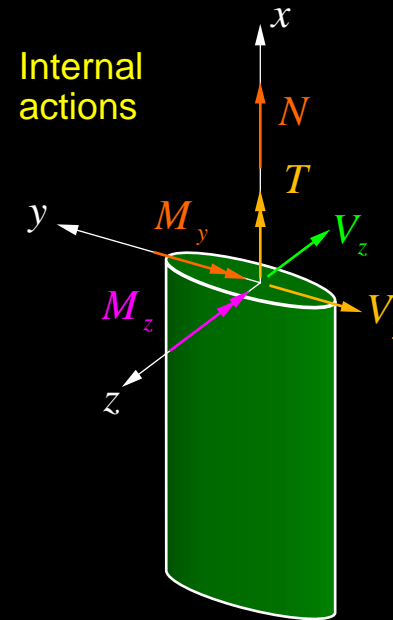

States of strain used to determine ultimate curvature and nominal resistance

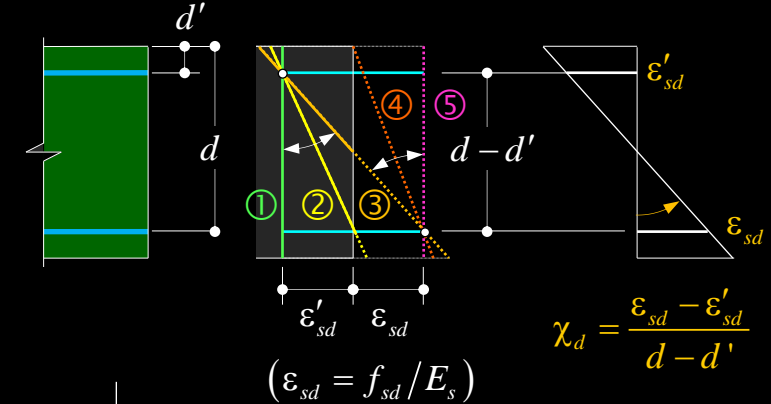

Static system / interaction diagram

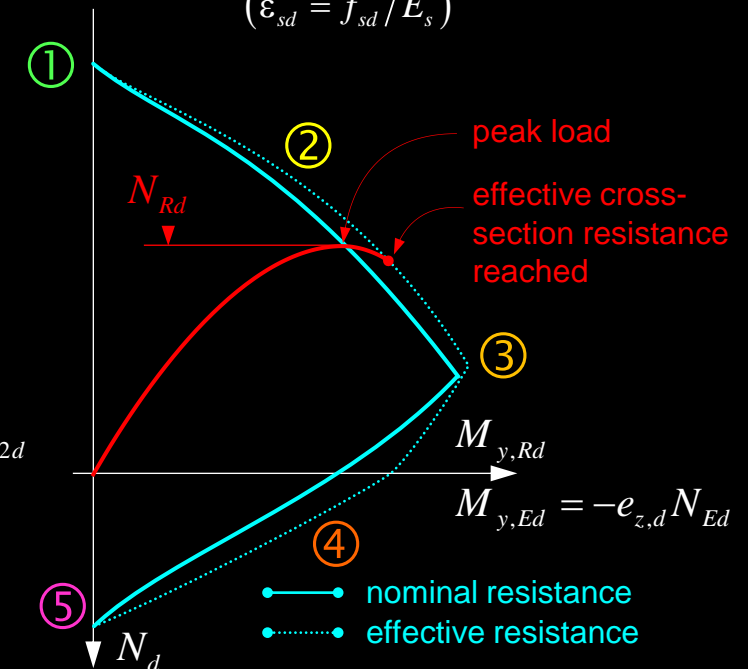
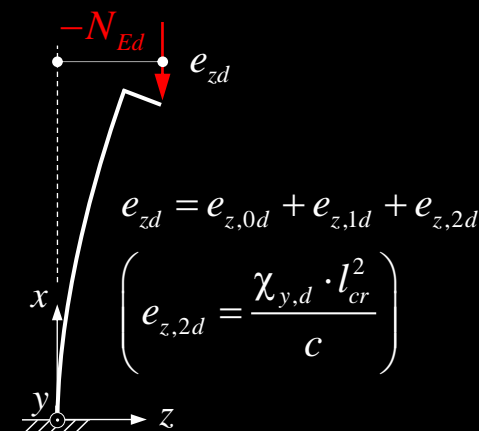

Substructure – Piers: Design / General observations

Geometrical imperfections

- **Design codes** provide values of geometrical imperfections that need to be considered in **standard cases**.
- According to SIA 262, a **base rotation** α has to be considered for vertical members

$$\frac{1}{200} \geq \alpha_i = \frac{0.01}{\sqrt{h}} \geq \frac{1}{300} \quad (h = \text{height of pier [m]})$$

and in the **design of compression members** the following eccentricity must be accounted for:

$$e_{0d} = \max \left(\begin{array}{l} \frac{d}{30} \\ \alpha_i \cdot \frac{l_{cr}}{2} \end{array} \right) \quad \left(\begin{array}{l} d = \text{static depth of cross-section} \\ l_{cr} = \text{buckling length} \end{array} \right)$$

- In exceptionally tall or slender piers, **special considerations may be appropriate**. For example, in the 145 m tall pier shown to the right, a base rotation of 1/300 would correspond to an eccentricity of 483 mm at the pier head (during construction, where $l_{cr} = 2h$). This eccentricity could be reduced by adopting strict geometrical control measures.

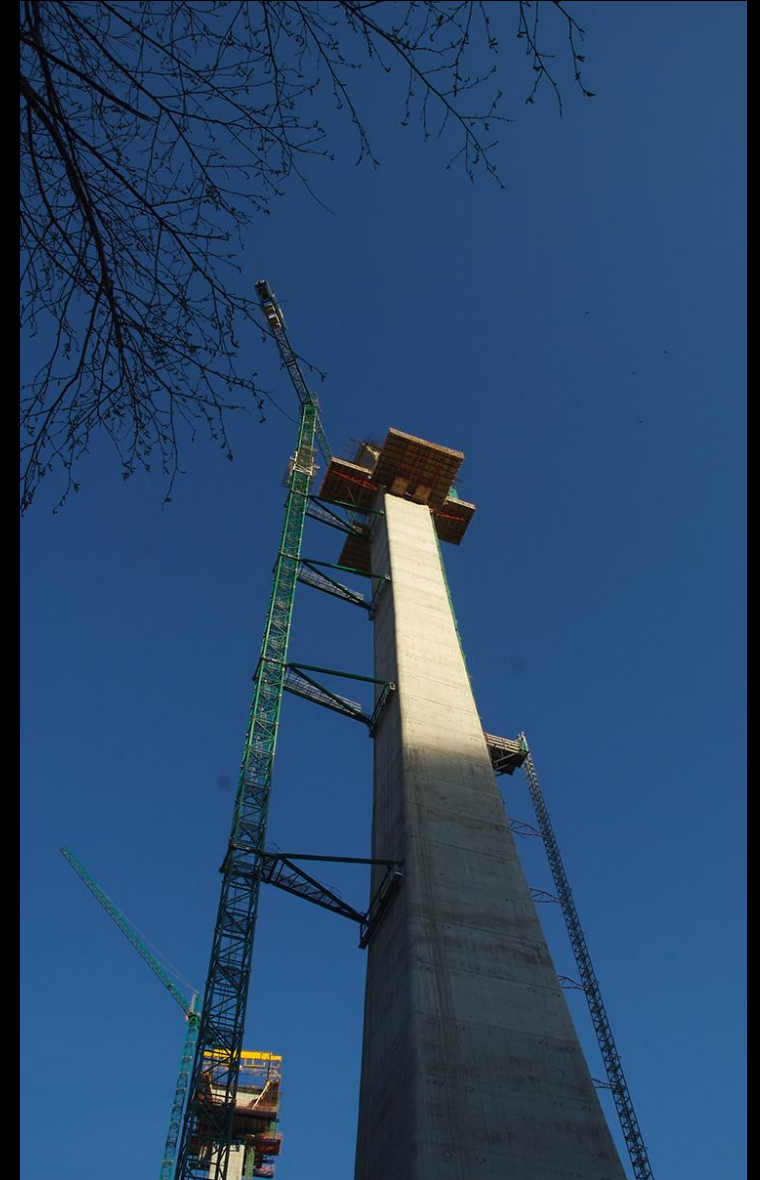

Substructure

Piers – Design

Horizontally separated piers
(piers with movable bearings at the top)

Substructure – Piers: Design / Horizontally separated piers

Horizontally separated piers (movable bearings at top)

Piers provided with longitudinally movable bearings at their top can be **analysed separately** from the superstructure

They may be safely designed e.g. using the curvature based method of SIA 262, **see Stahlbeton I**.

Compared to columns in buildings, there are some differences:

- **static systems**
 - ... **beam columns** (= pin-jointed piers) unusual in bridges
 - ... often statically indeterminate support
- much **higher loads**, pier dimensions and cross-sections
- usually **horizontal loads** (at pier top, not just accidental loads due to impact as in buildings)

The same design approach may also be used to estimate second order effects when pre-dimensioning piers with a horizontally fixed connection to the superstructure. In their final design, imposed pier head displacements need however to be accounted for → see behind

Design procedure according to SIA 262 (curvature based design)

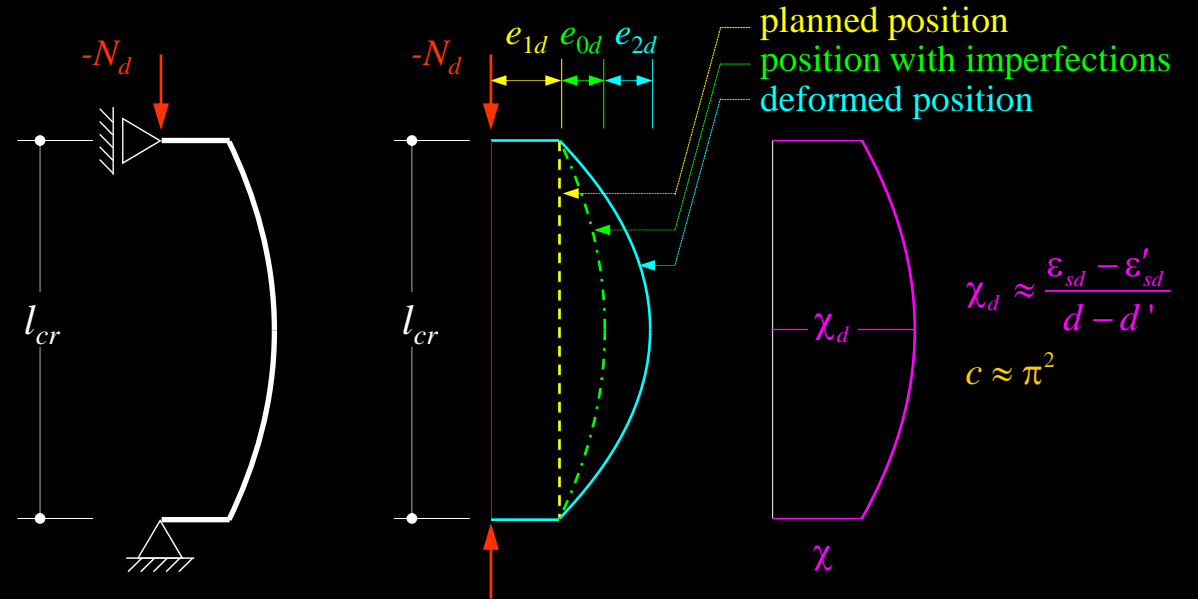

$$\chi_d \approx \frac{\varepsilon_{sd} - \varepsilon'_{sd}}{d - d'}$$

$$c \approx \pi^2$$

$$e_d = e_{0d} + e_{1d} + e_{2d}$$

$$e_{0d} = \max \left(\begin{array}{l} \frac{d}{30} \\ \alpha_i \cdot \frac{l_{cr}}{2} \end{array} \right)$$

$$e_{1d} = \frac{M_{1d}}{-N_d}$$

$$e_{2d} = \int_0^{l_{cr}} \chi \cdot \bar{M} dx = \chi_d \frac{l_{cr}^2}{c}$$

eccentricity due to geometric imperfection

$$\frac{1}{200} \geq \alpha_i = \frac{0.01}{\sqrt{h[m]}} \geq \frac{1}{300}$$

first order eccentricity of action

eccentricity due to member deformation

Substructure – Piers: Design / Horizontally separated piers

Horizontally separated piers (movable bearings at top)

Using the curvature based design approach of SIA 262, different loads (particularly horizontal loads) may be accounted for as illustrated (derivation see Stahlbeton I).

This slide recaps the **factors c_i** for the basic cases treated in Stahlbeton I (beam column and cantilever column). Other, statically indeterminate systems, common in bridge piers, and corresponding **factors c_i** are shown on the next slide.

If piers are stiff and/or the foundation is not sitting on rock, **piers are not fully clamped at the base** → use appropriate buckling length l_{cr} and c -factors.

Superposition of basic cases to a common **factor c** (derivation see Marti, Theory of Structures):

$$N_{cr,d} = -\frac{\pi^2 EI_d}{l_{cr}^2} \quad \alpha = \frac{N_d}{N_{cr,d}}$$

$$\rightarrow c = \alpha \cdot \pi^2 + (1 - \alpha) \frac{\sum M_{di}}{\sum \frac{M_{di}}{c_i}} \left(c_i = \frac{\chi_{mi} l^2}{e_{li}} = \frac{M_{li} \chi_{mi} l^2 / M_m}{\int_0^l \chi_i \bar{M} dx} \right)$$

Common load cases in piers and factors c for curvature based design

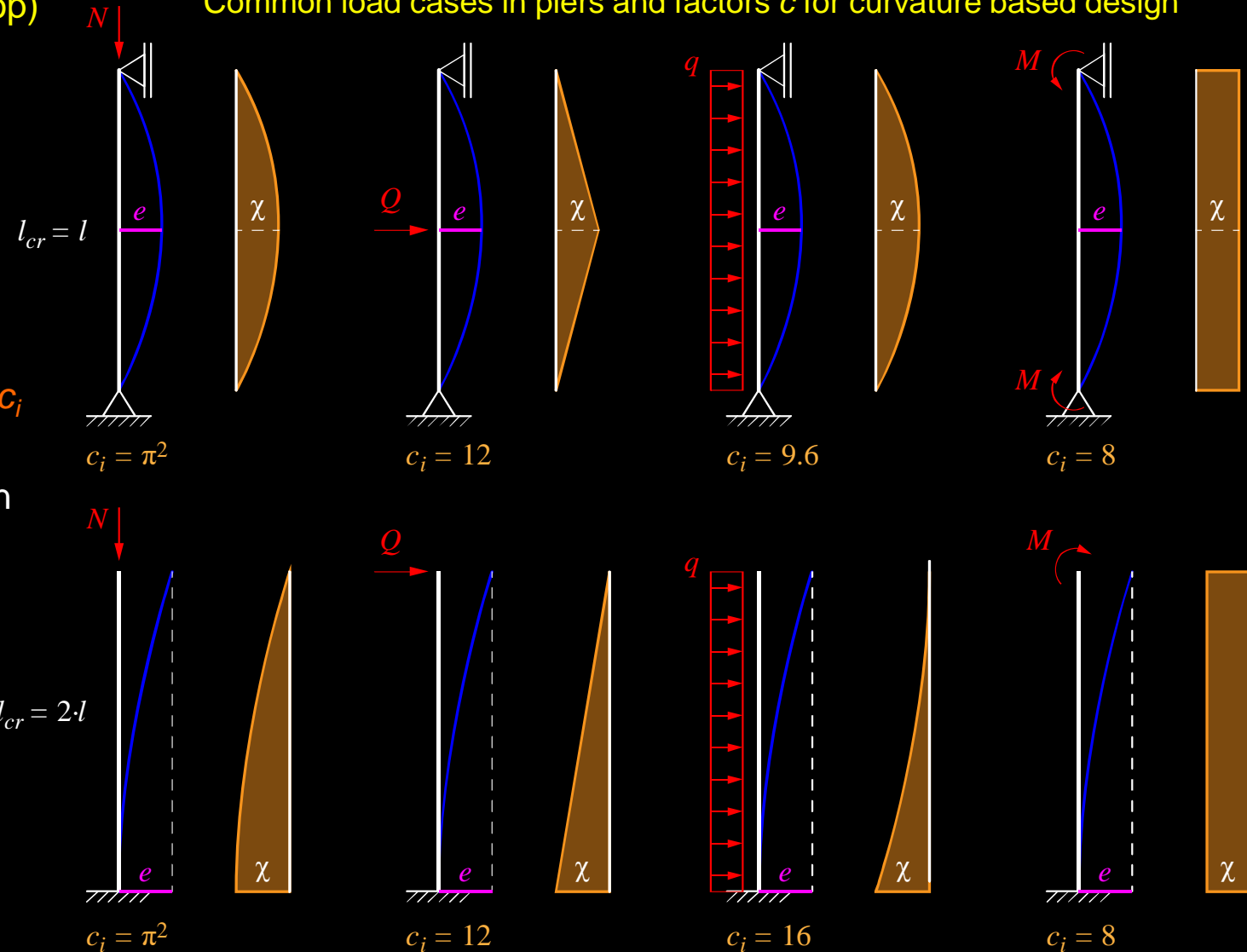

Substructure – Piers: Design / Horizontally separated piers

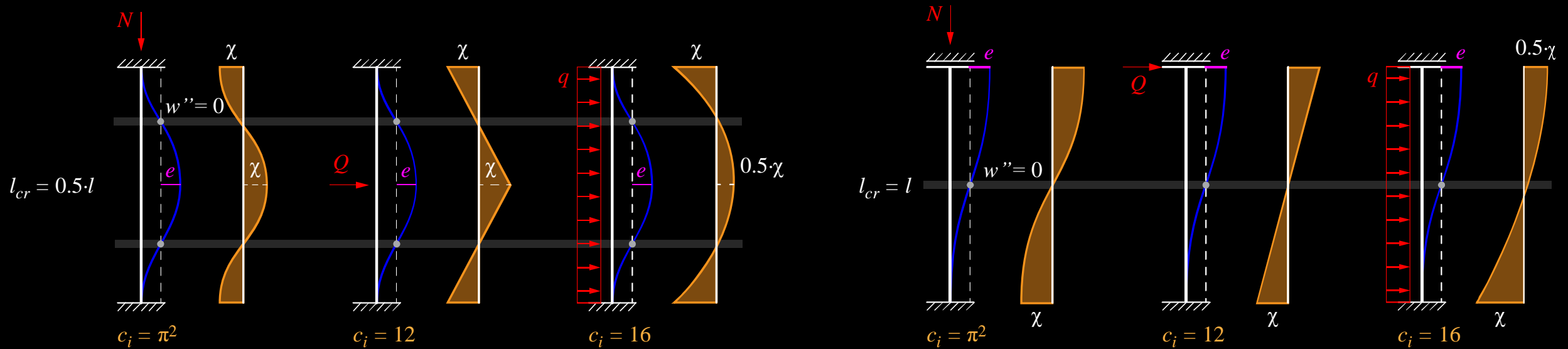

Statically indeterminate piers

For statically indeterminate piers, the **eccentricity e** that effectively contributes to the increase of the moment is the distance between the **deflection curve** and the secant through the points of inflection (where $\chi = 0$).

To allow the superposition of various load cases to a single c -factor despite different **curvature distributions**, the assumption is made that the points of inflections are the same as in the base case with a normal force on top (see notes).

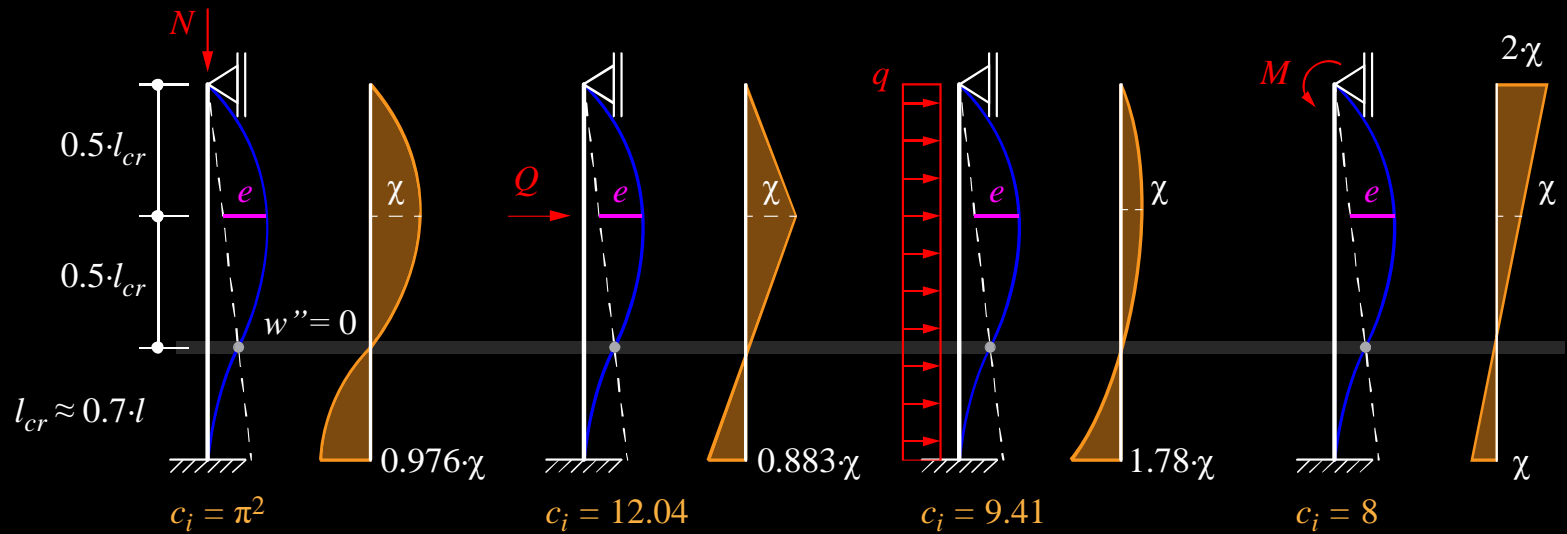

Substructure

Piers – Design

Piers connected to a longitudinally stabilised girder
(typically fixed at an abutment)

Substructure – Piers: Design / Piers connected to long. stabilised girder

Imposed pier head displacements – General

Piers longitudinally fixed to the girder can still be analysed individually, but the pier head displacements due to superstructure movements need to be accounted for.

While the design of cross-section resistances is analogous to piers with longitudinally movable bearings (see previous slides), determining the relevant internal actions and dimensioning the pier reinforcement is more complex:

- Imposed pier head displacements cause first and second order bending moments in the piers
- Different buckling lengths apply:
 - ... horizontal forces due to imposed pier head displacements (figure on right): pier head movable
 - ... buckling of individual piers: pier head hor. fixed
- Additional verifications are required to ensure appropriate behaviour in serviceability SLS (crack widths due to imposed deformation):
 - ... ULS: lower-bound value of pier stiffnesses EI_d
 - ... SLS: characteristic value of pier stiffnesses EI_k

Imposed pier head displacements and corresponding horizontal forces (second-order, $EI = \text{const}$; $N_{cr,d}$ and N_d are both $< 0 = \text{compression}$)

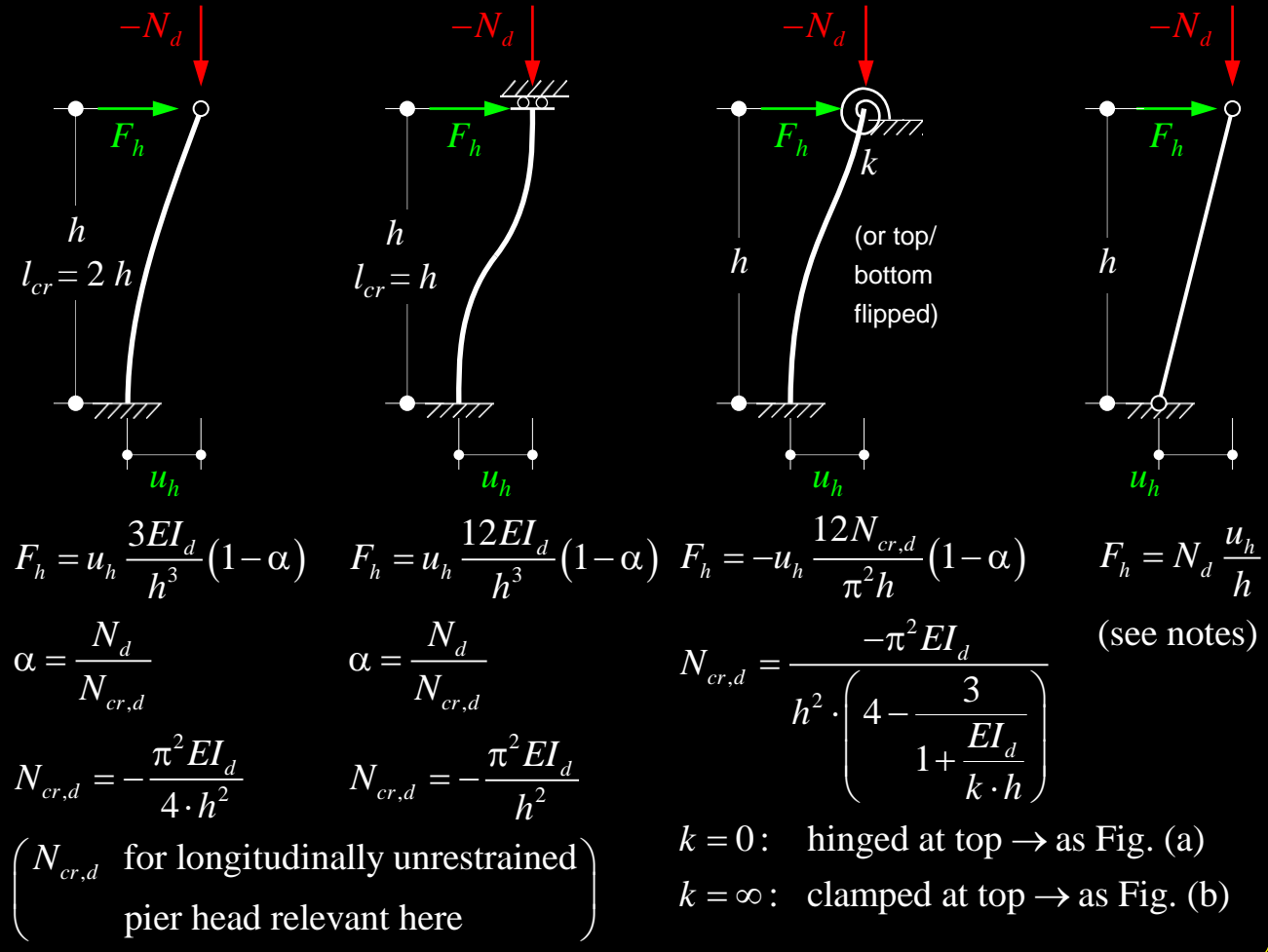

compression negative $\rightarrow N_d \leq 0, N_{cr,d} < 0$

Substructure – Piers: Design / Piers connected to long. stabilised girder

Imposed pier head displacements – Behaviour (1)

For a given imposed pier head displacement u_h , the following behaviour is observed under increasing vertical compressive normal force:

- The horizontal forces F_h caused by u_h (= the forces F_h required to displace the pier head by u_h) decrease with $|N_d|$ due to second order moments
- The magnitude of the «1st order bending moment», i.e. $(-F_h \cdot h$ at the pier base) decreases
- On the other hand, the magnitude of the 2nd order bending moment ($N_d \cdot u_h$ at pier base) increases
- Overall, the magnitude of the total bending moment at the pier base

$$M_{y,B} = -F_h \cdot h + N_d \cdot u_h$$

decreases, and the bending moment eventually changes sign (the moment diagram approaches that of the buckled individual pier)

Imposed pier head displacements and corresponding horizontal forces (second-order, $EI=\text{const}$; $N_{cr,d}$ and N_d are both < 0 = compression)

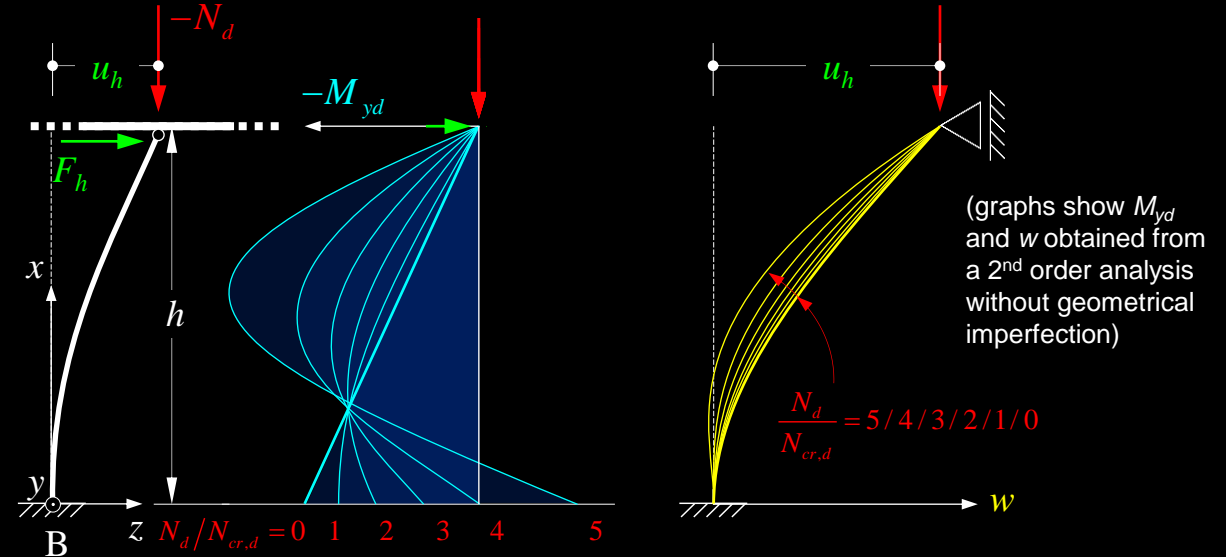

$$F_h = u_h \cdot \frac{3EI_d}{h^3} \left(1 - \frac{N_d}{N_{cr,d}} \right) \rightarrow u_h = \frac{F_h \cdot h^3}{3EI_d \left(1 - \frac{N_d}{N_{cr,d}} \right)} \quad N_{cr,d} = -\frac{\pi^2 EI_d}{4 \cdot h^2}$$

$$M_{y,B} = -F_h \cdot h + N_d \cdot u_h = -u_h \cdot \frac{3EI_d}{h^2} \left(1 + N_d \cdot \frac{4 \cdot h^2}{\pi^2 EI_d} \right) + N_d \cdot u_h$$

$$= -u_h \cdot \left[\frac{3EI_d}{h^2} + N_d \cdot \left(\frac{12}{\pi^2} - 1 \right) \right] \quad (\text{compression, i.e. } N_d < 0, N_{cr,d} < 0)$$

Substructure – Piers: Design / Piers connected to long. stabilised girder

Imposed pier head displacements – Behaviour (2)

(... continued ...)

- The **normal force N_d** can exceed the buckling load of the pier horizontally unrestrained at the top, i.e., $|N_d| > |N_{cr,d}|$ is possible since the pier head is fixed after imposing the displacement u_h (the buckling load of the restrained pier is $2^2/0.7^2 \approx 8$ times larger than $N_{cr,d}$ in accordance with the buckling lengths)
- For **normal forces N_d exceeding the buckling load** of the pier horizontally unrestrained at the top, i.e., $|N_d| > |N_{cr,d}|$, negative values of F_h result → the pier head **needs to be held back** to avoid instability
- The equation relating horizontal forces and pier head displacement (**factor $1 - N_d/N_{cr,d}$**) presumes affinity of deflections, which is less accurate at higher loads (buckled shape of pier differs strongly from deflection due to pier head displacement)
- The diagram to the right compares the results of the approximation with an elastic 2nd order analysis

Imposed pier head displacements and corresponding horizontal forces (second-order, $EI = \text{const}$; $N_{cr,d}$ and N_d are both $< 0 = \text{compression}$)

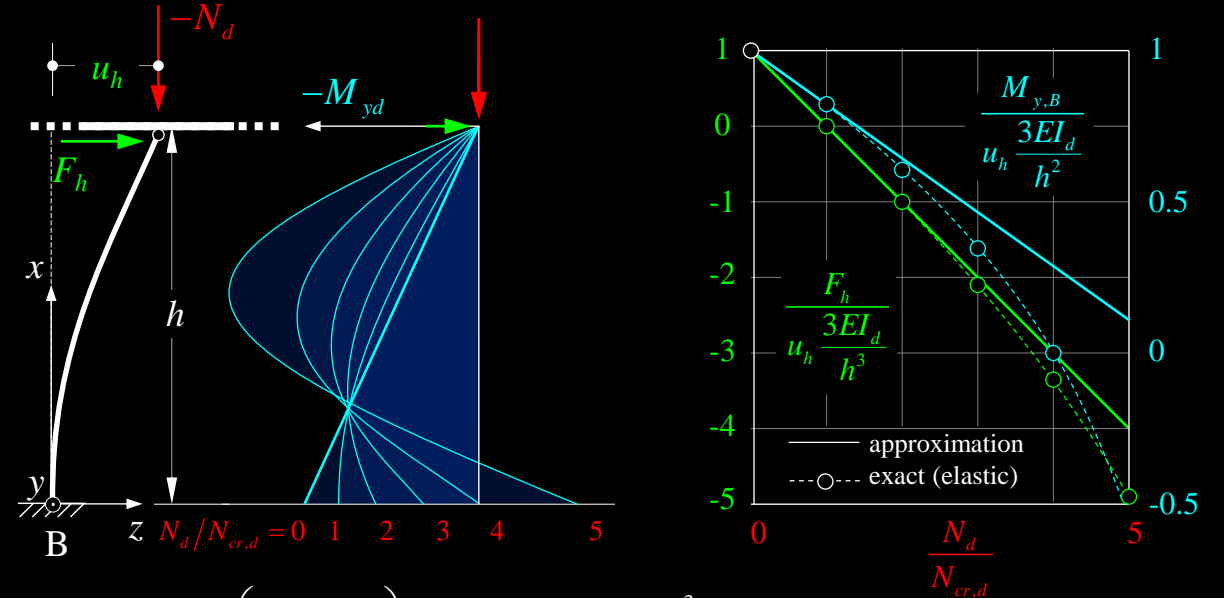

$$F_h = u_h \cdot \frac{3EI_d}{h^3} \left(1 - \frac{N_d}{N_{cr,d}} \right) \rightarrow u_h = \frac{F_h \cdot h^3}{3EI_d \left(1 - \frac{N_d}{N_{cr,d}} \right)} \quad N_{cr,d} = -\frac{\pi^2 EI_d}{4 \cdot h^2}$$

$$M_{y,B} = -F_h \cdot h + N_d \cdot u_h = -u_h \cdot \frac{3EI_d}{h^2} \left(1 + N_d \cdot \frac{4 \cdot h^2}{\pi^2 EI_d} \right) + N_d \cdot u_h$$

$$= -u_h \cdot \left[\frac{3EI_d}{h^2} + N_d \cdot \left(\frac{12}{\pi^2} - 1 \right) \right] \quad (\text{compression, i.e. } N_d < 0, N_{cr,d} < 0)$$

Substructure – Piers: Design / Piers connected to long. stabilised girder

Imposed pier head displacements – Imperfections

- So far, no **geometric imperfections** e_{0d} were considered. These may have a **beneficial or detrimental effect** on the bending moments in the pier, depending on
 - the **slenderness and level of compressive force**
 - the ratio between **imposed deformation** and **geometric imperfection**
 - the **position** along the pier

Typically, including e_{0d} is favourable at the pier base but unfavourable higher up, and less relevant for low normal force and/or slenderness

Imposed pier head displacements and corresponding horizontal forces (second-order, $EI=\text{const}$; $N_{cr,d}$ and N_d are both $< 0 = \text{compression}$)

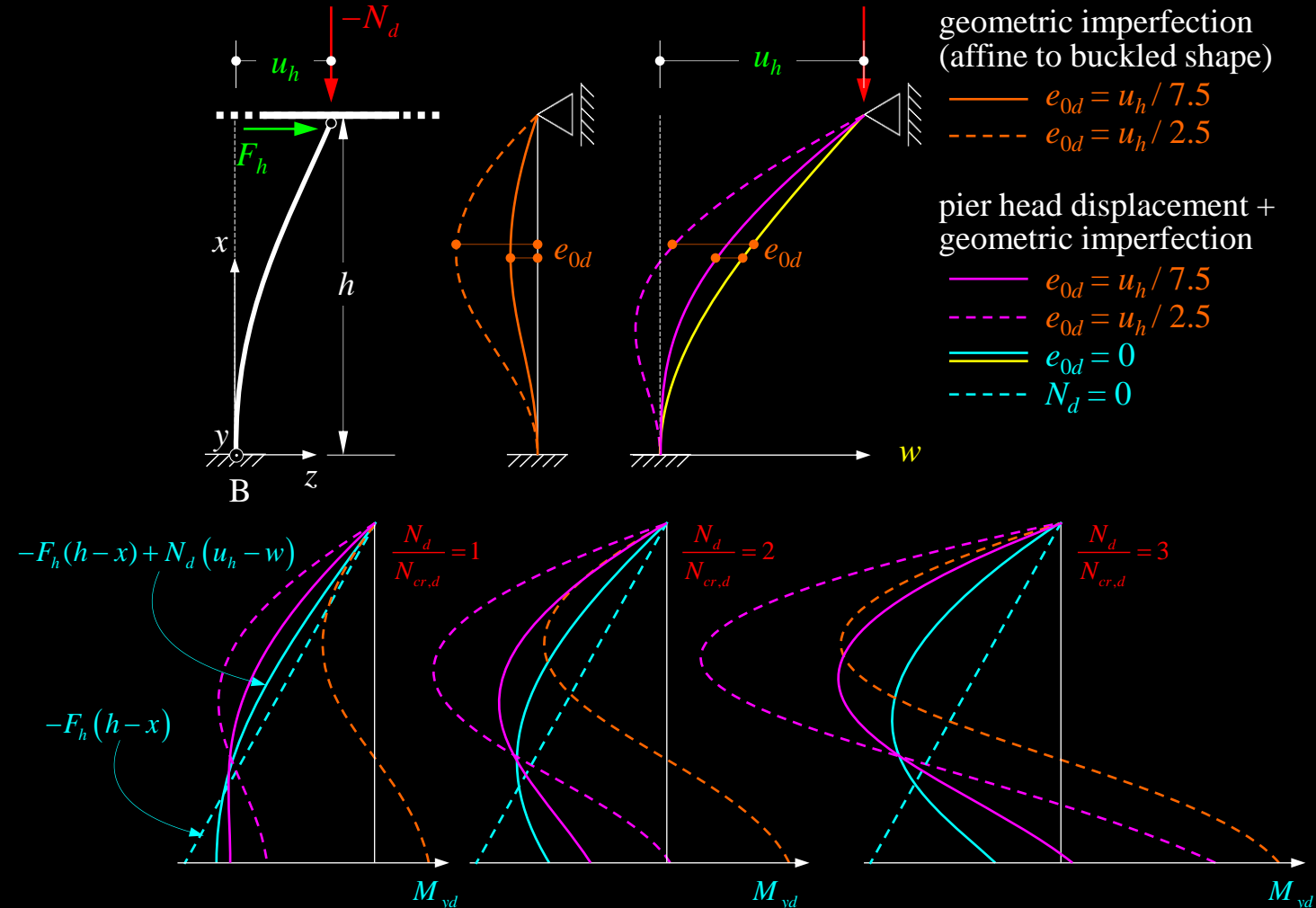

Substructure – Piers: Design / Piers connected to long. stabilised girder

Imposed pier head displacements – Design (1)

- The application of approximate methods (e.g. curvature-based design) is not straightforward, since the geometric imperfection e_{0d} and the imposed deflections w have completely different shapes (much more pronounced than different positions of points of inflection when determining factors c in statically indeterminate piers, see previous slides)
 - except for low normal force / slenderness (→ neglect beneficial e_{0d}), a 2nd order analysis is recommended
 - constant, conservative value of EI_d sufficient except for slender piers, where refined calculations accounting for material nonlinearity are adequate
- For low slenderness and preliminary design, the bending moments may be estimated as indicated in the figure, assuming parabolic $w(x)$ and checking pier base and position where $M_{yd}(e_{0d}) = 0.733e_{0d} N_d (1-\alpha)$

Note: The principles outlined for a pier hinged at its top also apply to piers monolithically connected to the girder.

Approximate determination of bending moments due to imposed pier head displacement accounting for 2nd order effects

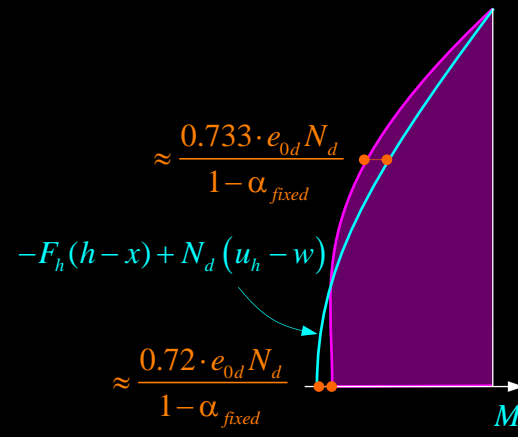
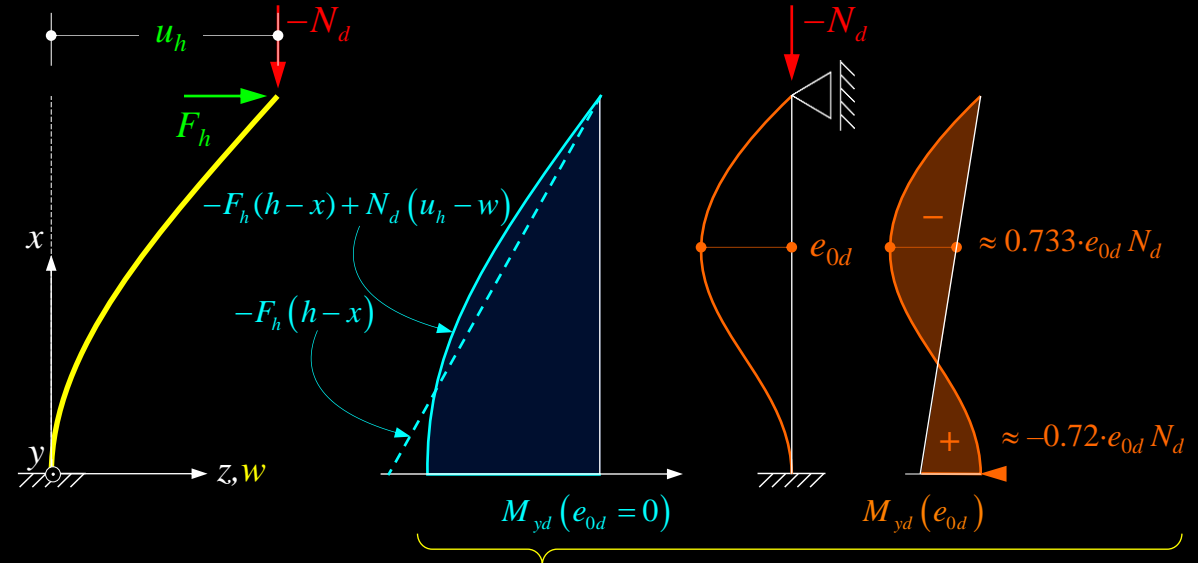

$$M_y(x) = -F_h(h-x) + N_d(u_h - w(x)) + \frac{M_{yd}(e_{0d})}{1 - \alpha_{fixed}} =$$

$$= -u_h \cdot (h-x) \cdot \left[\frac{3EI_d}{h^3} + N_d \cdot \left(\frac{12}{\pi^2} - \frac{1-w(x)}{h-x} \right) \right] + \frac{M_{yd}(e_{0d})}{1 - \alpha_{fixed}}$$

$$\left(\alpha_{fixed} = \frac{N_d}{N_{cr_fixed,d}}; N_{cr_fixed,d} = \frac{\pi^2 EI_d}{l_{cr_fixed}^2} \approx \frac{\pi^2 EI_d}{(0.7h)^2} \right)$$

Substructure – Piers: Design / Piers connected to long. stabilised girder

Imposed pier head displacements – Design (2)

As outlined in *Support and Articulation*:

- The displacements imposed to the pier heads in fixed systems are caused by movements of the girder due to **temperature variations** $\varepsilon_{\Delta T}$, **shrinkage** ε_{cs} , **prestressing** ε_{cp} , and **creep** $\varepsilon_{cc} = \varphi \cdot \varepsilon_{cp}$
- The **axial stiffness of the girder** is orders of magnitude higher than the flexural stiffness of piers
 - the **design pier head displacements** can be determined using the **free (unrestrained) girder expansion and contraction**, considering that
 - the **movement lengths vary** in staged construction
- While **bending moments** are reduced by long-term effects (creep and relaxation), pier head displacements – causing 2nd order moments and relevant for bearing (and expansion joint) movement capacity – are not!
- The **fixed abutment** needs to be designed to **resist the sum of horizontal forces** F_h at all pier tops (in addition to applied horizontal loads), see abutment design

Movements of superstructure (due to girder contraction) imposed to piers (schematic, horizontal fixity at right abutment A2)

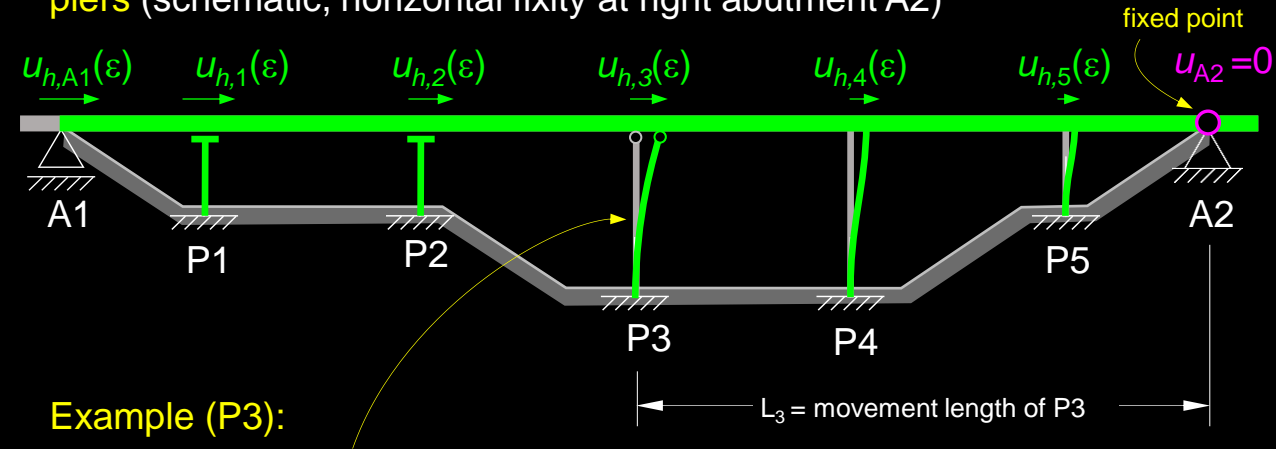

Example (P3):

Total imposed pier head displacement (assuming one-casting system):

$$u_{h,3}(\varepsilon) = (\varepsilon_{\Delta T} + \varepsilon_{cs} + \varepsilon_{cp} \cdot (1 + \varphi)) \cdot L_3$$

Pier head displacement ↔ design of slender piers (previous slides):

$$u_{h,3}(\varepsilon) = \varepsilon_{\Delta T} \cdot L_3 + \dots \quad \text{use short-term pier stiffness}$$

$$\dots + (\varepsilon_{cs} + \varepsilon_{cp} \cdot (1 + \varphi)) \cdot L_3 \quad \text{use long-term pier stiffness, e.g. } E_c / (1 + \varphi)$$

Approximation of restraint force applied to pier head of non-slender piers:

$$F_h = F_h(\varepsilon_{\Delta T} \cdot L_3) + \dots \quad \text{use short-term pier stiffness}$$

$$\dots + F_h(\varepsilon_{cs} \cdot L_3) + \dots \quad \text{use age-adjusted pier stiffness (see notes), } E_c / (1 + \mu\varphi)$$

$$\dots + F_h(\varepsilon_{cp} \cdot L_3) \quad \text{use short-term pier stiffness (see notes)}$$

[or $F_h(\varepsilon_{cp} \cdot (1 + \varphi) \cdot L_3)$ with long-term pier stiffness]

Substructure

Piers – Design

Flexible systems

(piers longitudinally stabilising the girder)

Substructure – Piers: Design / Flexible systems

General behaviour

In bridges longitudinally stabilised by (slender) piers, the following verifications of the piers are required:

- **System stability**, i.e., safety against instability of the entire system → **rigid body movement** of girder
- **ULS and SLS of individual piers**, accounting for imposed pier head displacements (previous slides) including the **rigid body movement** determined above

Considering that the girder is axially very stiff, the pier head displacements consist of two main contributions:

- displacements caused by (\approx unrestrained) girder expansion and contraction due to **temperature variations** $\varepsilon_{\Delta T}$, **shrinkage** ε_{CS} , **prestressing** ε_{cp} , and **creep** $\varepsilon_{cc} = \varphi \cdot \varepsilon_{cp}$ (upper figure)
 - different $u_{h,i}(\varepsilon)$ for each pier
 - horizontal forces $F_{h,i}$ of all piers cancel out
- displacements caused by **rigid body movements of the girder** due to applied loads (lower figure)
 - equal for all piers $u_{h,i}(H_d) = u_h(H_d)$
 - sum of horizontal forces $F_{h,i} =$ applied load H_d

Bridge longitudinally stabilized by piers: Movements due to girder contraction (schematic)

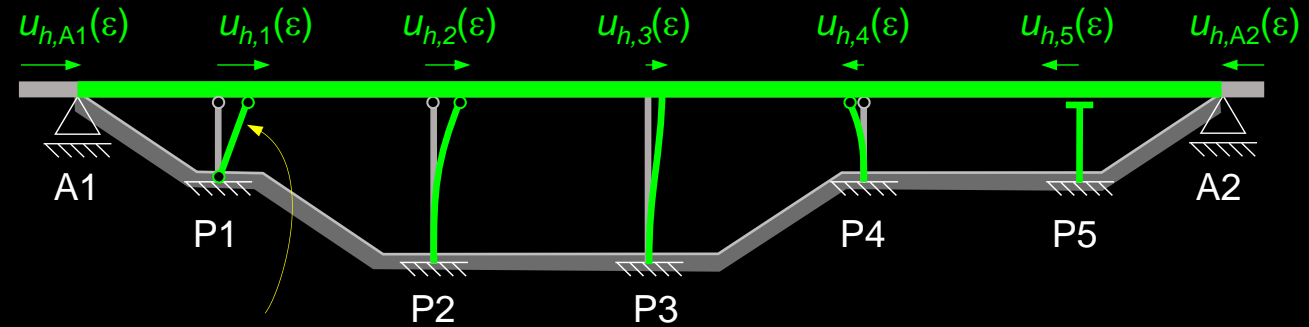

pin-jointed pier (unusual, included for illustration)

Bridge longitudinally stabilized by piers: Rigid body girder movement due to load (schematic)

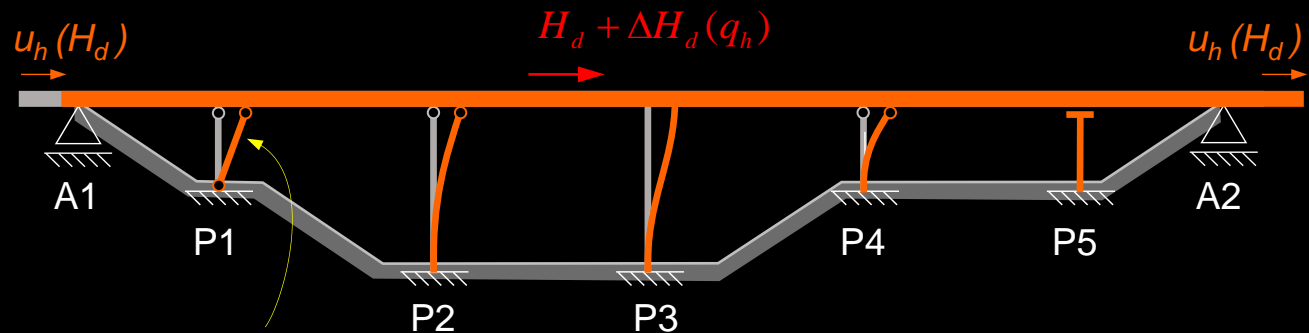

pin-jointed pier (unusual, included for illustration)

Substructure – Piers: Design / Flexible systems

System stability – Basics

A rigorous verification of the system stability is complex and subjected to many uncertainties.

→ usually, a simplified approach is therefore used, see below and next slides

As long as piers are not extremely slender, system stability can be verified using the **linear relationship between pier head displacement and horizontal loads** used before (Figures a-c):

- Piers (a)-(c) with $|N_d| < |N_{cr,d}|$ **stabilise** the system
- Piers (a)-(c) with $|N_d| > |N_{cr,d}|$ **destabilise** the system

In addition, pin-jointed members (d) need to be considered. These are **always destabilising (for compression $N_d < 0$)**, and more so if they are short.

To account for the normal forces due to **pier weight**, a **third of the pier weight** should be added to N_d in the analysis.

Imposed pier head displacements and corresponding horizontal forces (second-order, $EI = \text{const}$; $N_{cr,d}$ and N_d are both $< 0 = \text{compression}$)

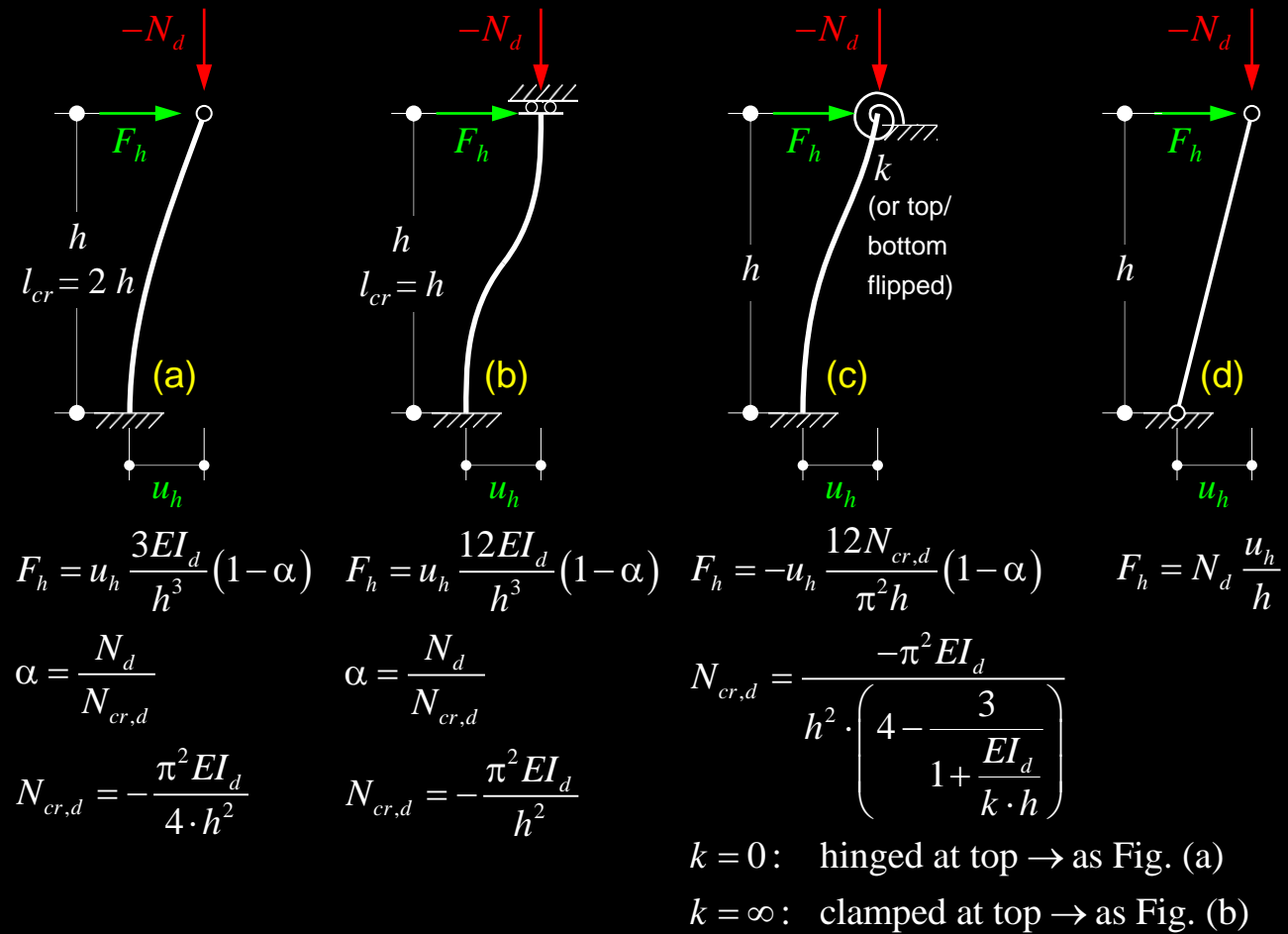

note: compression negative → $N_d \leq 0, N_{cr,d} < 0$

Substructure – Piers: Design / Flexible systems

System stability – Determination of girder displacement

Approximation neglecting the contribution of geometrical imperfections and imposed deformations to u_h :

Horizontal loads q_h applied to the piers (earthquake, wind, ...) need to be resisted by the system as well
 → add reactions $\Delta H_d(q_h)$ at pier tops to H_d .

Since the relationship between u_h and F_h is linear for all piers (and the displacements caused by girder expansion and contraction do not contribute to H_d), the **rigid body displacement** u_h of the girder can be determined as follows (stable if $u_h > 0$):

$$\sum_i F_{h,i} + \sum_j F_{h,j} = H_d + \Delta H_d(q_h)$$

$$u_h \cdot \left(\frac{12}{\pi^2} \sum_i \frac{N_{d,i} - N_{cr,d,i}}{h_i} + \sum_j \frac{N_{d,j}}{h_j} \right) = H_d + \Delta H_d(q_h)$$

$$\rightarrow u_h = \frac{H_d + \Delta H_d(q_h)}{\frac{12}{\pi^2} \sum_i \frac{N_{d,i} - N_{cr,d,i}}{h_i} + \sum_j \frac{N_{d,j}}{h_j}} \geq 0$$

"i": all non pin-jointed piers
 ≥ 0 for $|N_{cr,d,i}| \geq |N_{d,i}|$
 < 0 else (slender piers)

"j": pin-jointed piers
 → always destabilising
 $(N_{d,j} < 0)$

Longitudinal forces applied to the piers (schematic)

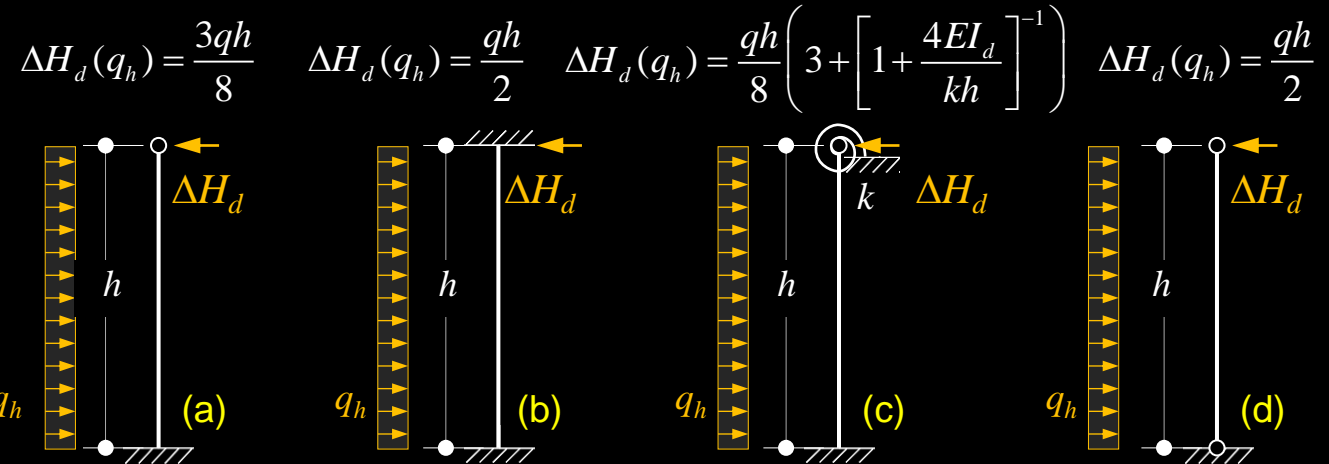

Equilibrium of longitudinal forces acting on girder

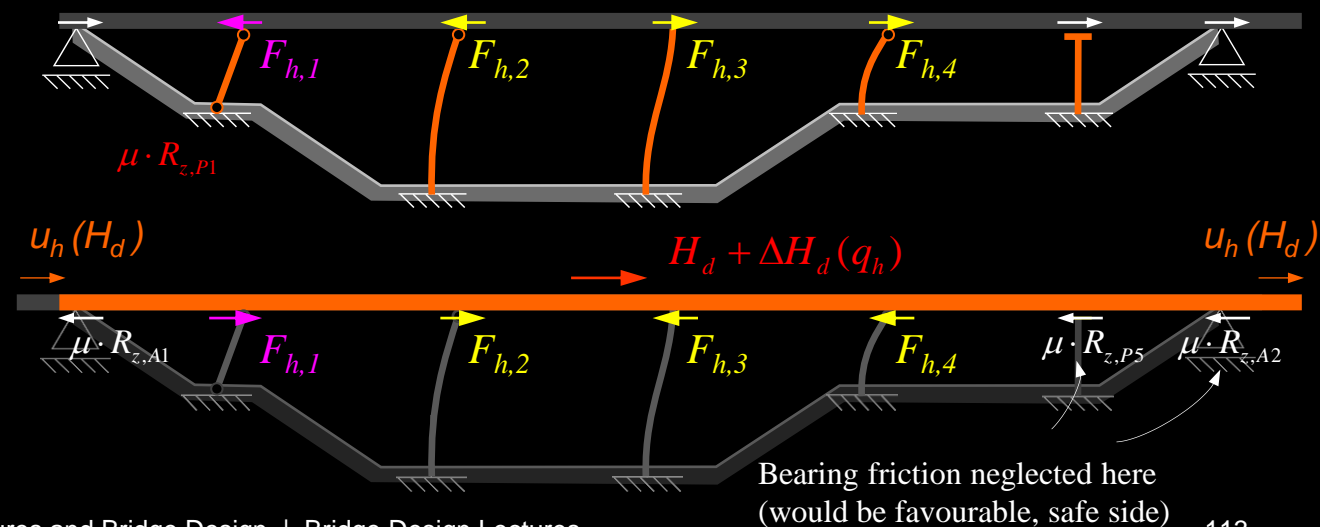

Substructure – Piers: Design / Flexible systems

ULS and SLS design of individual piers (1)

The design pier head displacements, used for the dimensioning of the individual piers, follow by superimposing

- the girder displacement $u_h(H_d)$, see previous slide (when using 'exact' formulas: $u_h(H_d; u_{h,0}; u(\varepsilon))$)
- the displacements $u_h(\varepsilon)$ due to girder expansion and contraction
- an additional displacement $u_{h,0d}$ accounting for geometric imperfections, e.g. according to SIA 262

$$u_{h,0d} = \alpha_i \cdot h_{\max}, \quad \frac{1}{200} \geq \alpha_i = \frac{0.01}{\sqrt{h_{\max} [m]}} \geq \frac{1}{300} \rightarrow \frac{h_{\max}}{200} \geq u_{h,0d} = \frac{\sqrt{h_{\max} [m]}}{100} \geq \frac{h_{\max}}{300}$$

These displacements must be superimposed in the **most unfavourable combination**, considering different cases (expansion / contraction of girder, positive / negative longitudinal forces on girder, ...):

$$u_{h,tot,i} = \pm u_{h,0d,i} \pm u_{h,i}(\varepsilon) \pm u_{h,i}(H_d)$$

and accounting for the fact that the fixed point position is not exactly known but depends on the **stiffness of the foundations** (see behind) and **the piers**. As approximation for the latter, the design stiffness $EI_d \approx 230 M_{Rd}(d-d')$ may be used with an estimated reinforcement content in preliminary design.

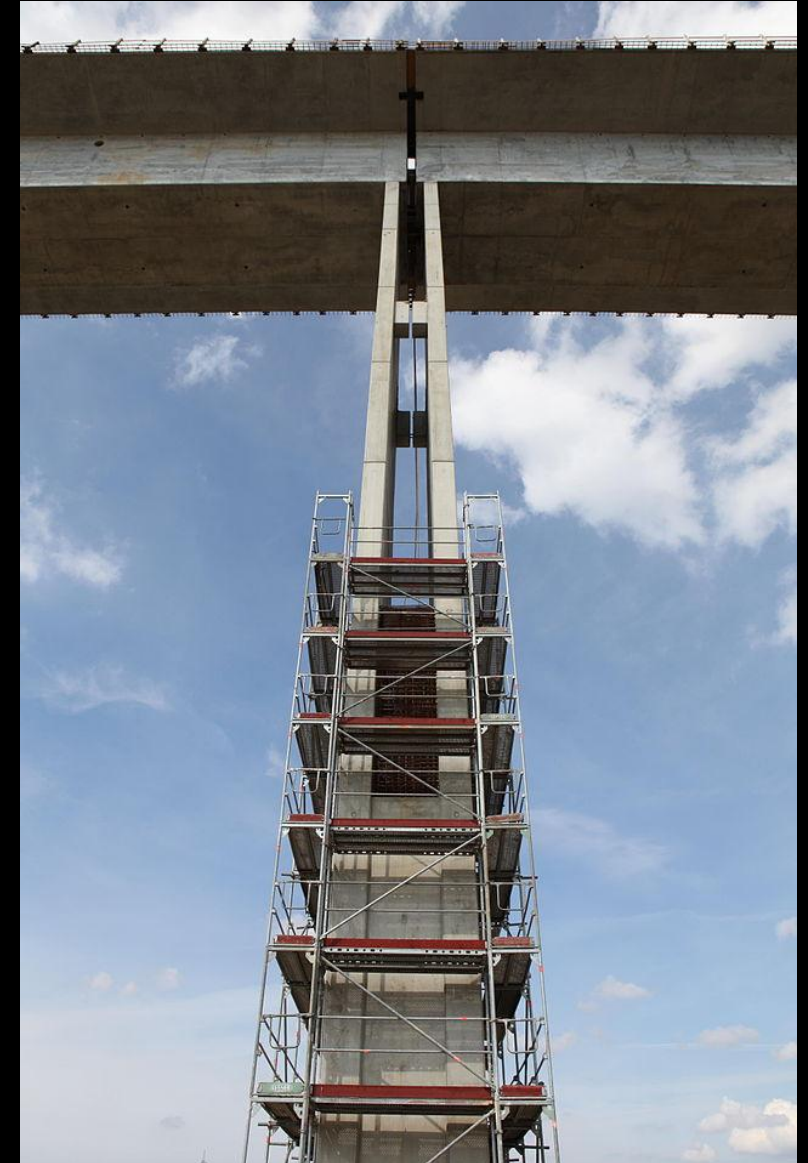

Substructure – Piers: Design / Flexible systems

ULS and SLS design of individual piers (2)

Each individual pier is then dimensioned for its **governing pier head displacements** $u_{h,tot}$ as outlined for piers fixed to a girder stabilised longitudinally at an abutment:

- in **ULS** using **lower-bound values of pier stiffnesses** EI_d (using $EI_d \approx 230 M_{Rd} (d-d')$ for all piers is sufficient except in slender piers/systems, where it may be overly conservative)
- in **SLS** using **characteristic values of pier stiffnesses** EI_k (accounting for cracking, which reduces bending moments and minimum reinforcement demand)

The procedure outlined on the previous slides is applicable in cases where the **linear relationship between pier head displacement and horizontal loads** is reasonably accurate (no extremely slender piers), and as long as the assumption of a conservative design stiffness EI_d for all piers is not overly conservative.

In other cases, a **second order calculation of the entire system** – following similar lines as in the approximation, but using less conservative pier stiffnesses but accounting for geometric imperfections of the individual piers – is recommended.

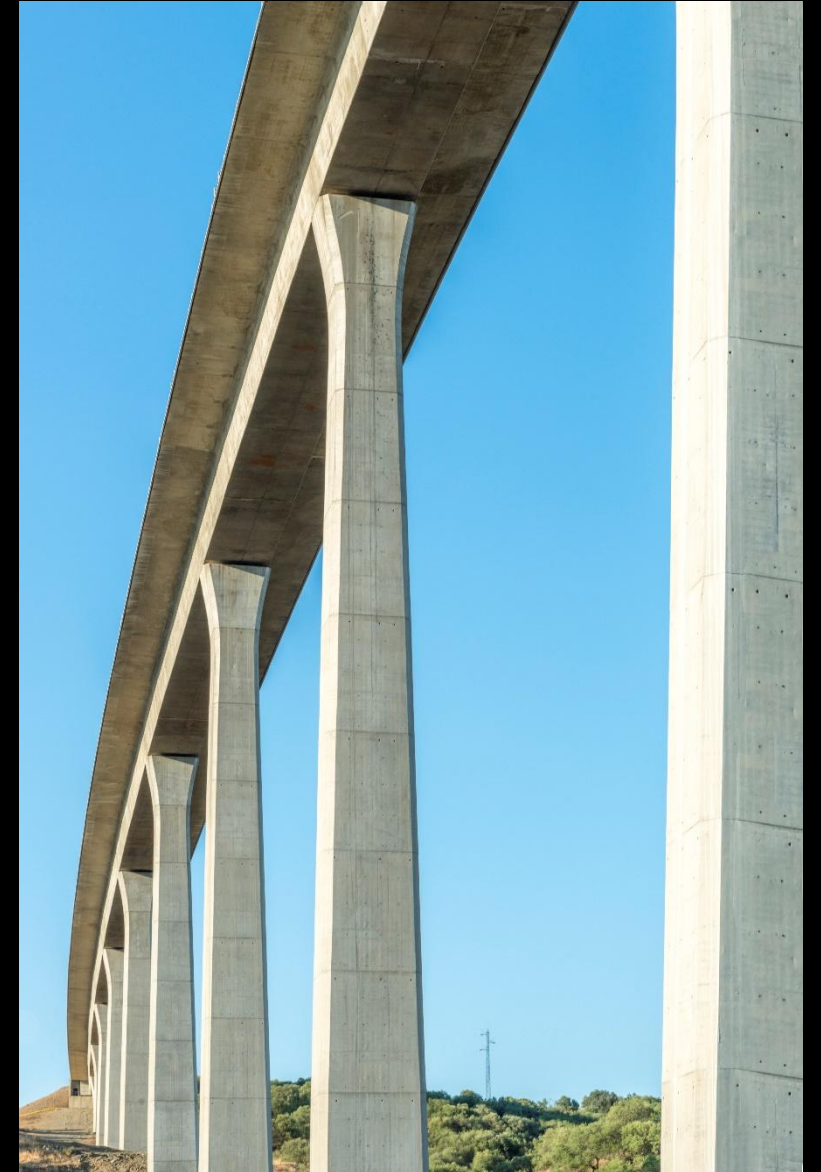

Abutments

Nomenclature and function



Classification / examples



Design



Dimensioning



Piers

General remarks and aesthetics



Construction



Design



Foundations

Types



Selected design aspects



Scour protection

Substructure

Foundations

Substructure

Foundations – Types

Substructure – Foundations: Types

Spread footings

Spread footings are usual for abutments due to their large dimensions.

On relatively stiff soil at shallow depth, spread footings may also be used for piers. Since pier reactions are often high, correspondingly large dimensions are required except in solid rock.

If soft soil layers extend several meters from the surface, excavation pits become large and expensive → pile foundation more economical.



Substructure – Foundations: Types

Pile foundations – Driven piles

In soft soil, **driven piles** (“Rammpfähle”) of small-medium diameter (40...60 cm) are economical, since **skin friction** carries most of the load. Driven piles may be **prefabricated** (e.g. spun concrete / Schleuderbetonpfähle) or **cast in situ** (Ortbetonrammpfähle).

Several driven piles are required per pier foundation. These piles are commonly **connected through a pile cap** accommodating tolerances and carrying the pier.



Substructure – Foundations: Types

Pile foundations – Bored piles (aka “drilled pier foundations”)

In stiffer soil, **bored piles** (“Bohrpfähle”) are used, with larger diameter than driven piles. Bored piles carry more load and are also better suited to transfer horizontal loads.

Bored piles may be **cased** (**verrohrt**) or **uncased** (**unverrohrt**), depending on borehole stability. In piles reaching below the groundwater level, **water ingress must be prevented** (fill casing with water or bentonite suspension). Concrete is **cast using hoses** (**tremie pipes**) (Contractorverfahren) to prevent segregation.

While pile diameters of 1.20 m were considered as very large few decades ago, **diameters of 1.50 m or even 1.80 m are common today**. As a prerequisite, **large machinery** must be able to access the site.

Compared to driven piles, fewer piles are required per pier foundation. Still, they are commonly **connected through a pile cap** accommodating tolerances and carrying the pier.

Ultrasonic pile integrity checks (using tubes installed before casting) are common today. Alternatively, impact echo testing is also used, but is less reliable.



Substructure – Foundations: Types



Rotary drill



Concreting

Pile heads



Pile cap

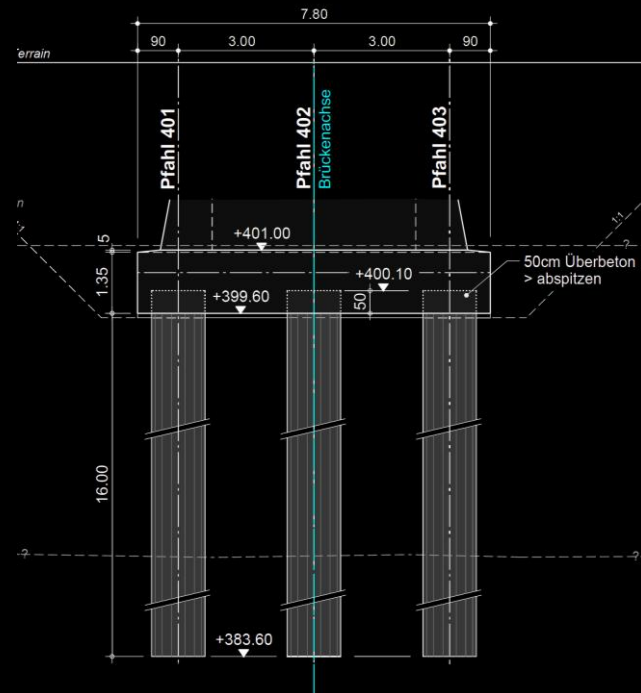

Pile cap formwork



Substructure – Foundations: Types

Pile foundations – pile tests

The dimensioning of pile foundations is often conservative, since the soil properties at large depths are uncertain.

In-situ static pile tests allow accounting for higher bearing capacities. Due to the high cost of such tests, and lack of time in most projects, they are only rarely carried out.

In the example shown in the photos, roughly 20% of the planned total pile length of 9.6 km could be saved, making the tests worthwhile.

Alternatively, dynamic pile tests are also being used. They are less expensive, but yield less direct information on the bearing capacity (→ higher safety margin required)



Substructure – Foundations: Types

Shaft foundations (aka “excavated pier foundations”)

Shaft foundations are a viable alternative to transfer loads to stiff soil (rock) in moderate depth. The shafts are excavated to the required depth resp. the desired soil layer (typically rock) and filled with concrete reinforced in the upper part.

An advantage of shafts is that the soil properties at foundation level can be examined 1:1.

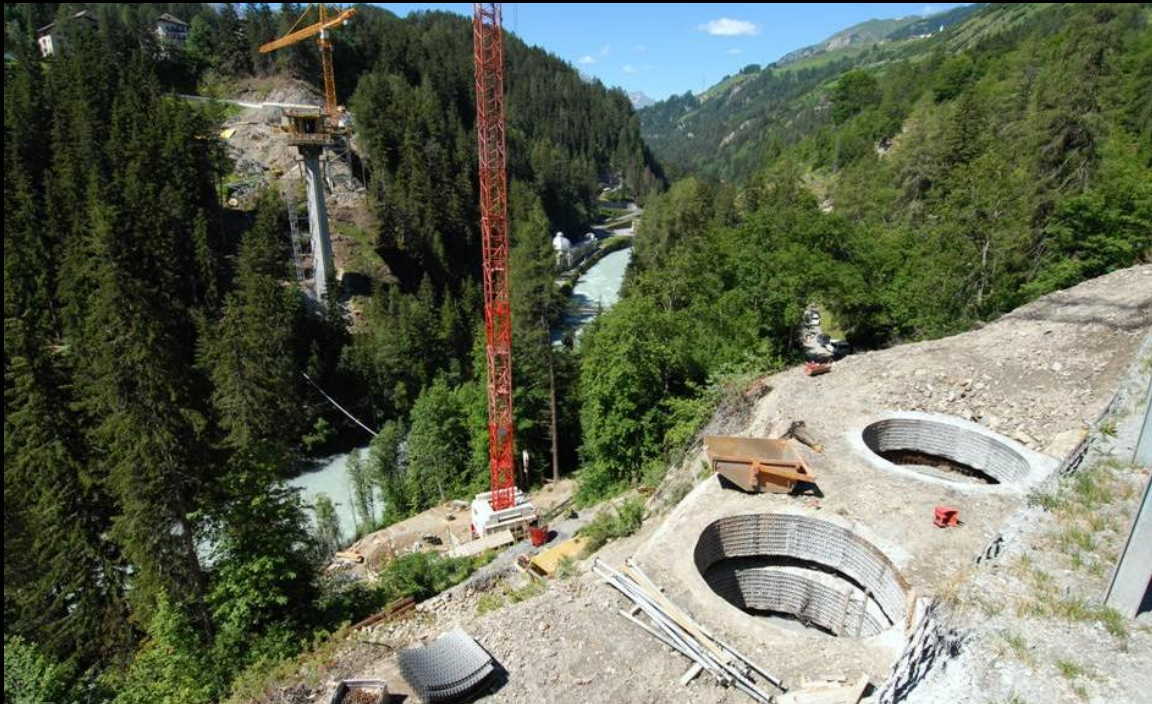

Substructure – Foundations: Types

Caisson foundations

Caissons are watertight prismatic hollow foundation structures built above the ground level and sunk to the required depth for foundations under the water level. The following types can be distinguished:

- **Pneumatic caissons** are bottomless boxes, filled with compressed air to keep the water out and provide a dry working chamber where excavation can be carried out. They were used where open caissons could not be sunk due to obstacles (boulders), or would be unstable.

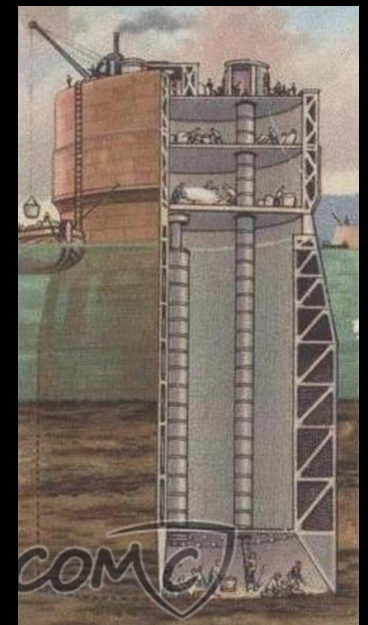
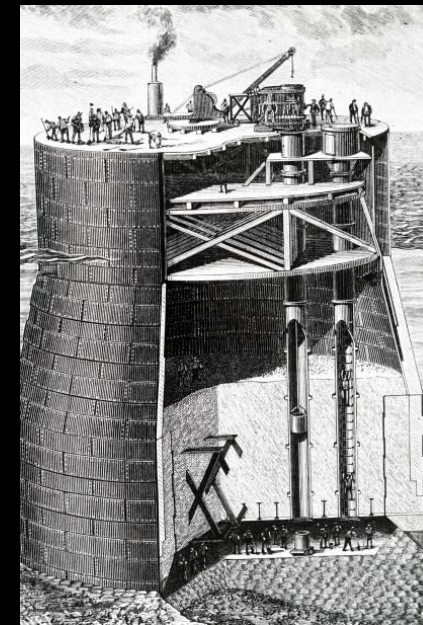
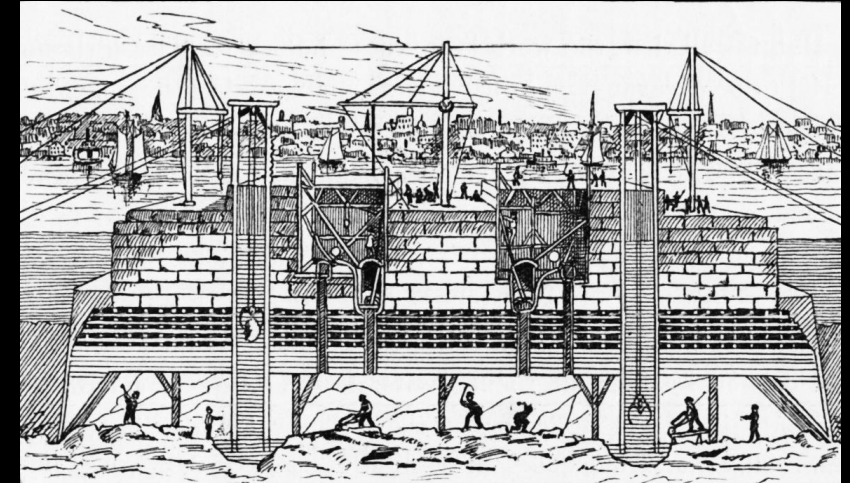

Substructure – Foundations: Types

Caisson foundations

Caissons are **watertight prismatic hollow foundation structures** built above the ground level and sunk to the required depth for foundations under the water level. The following types can be distinguished:

- **Pneumatic caissons** are bottomless boxes, filled with compressed air to keep the water out and provide a dry working chamber where excavation can be carried out. They were used where open caissons could not be sunk due to obstacles (boulders), or would be unstable.
- **Open caissons** have neither top nor bottom cover. They were used mainly for foundations in sandy soil and shallow water, typically using the “sand island method” and underwater excavation using clamshells.
- **Box caissons** are closed on the bottom and lowered through water onto a prepared foundation layer, typically consisting of a sand bed. Alternatively, steel caissons serving as formwork for underwater concrete are also used.

While they were widely used in the past, **caissons have become largely obsolete** through the development of other methods, particularly large diameter bored piles.



Substructure

Foundations – Selected design aspects

Substructure – Foundations: Selected design aspects

General remarks and stiffness of spread footings

- Foundations are an **important part of bridges**, and often **high vertical loads** need to be transferred to the subsoil
 - strength (“bearing capacity”) of foundation highly relevant
 - pile foundations frequent
- If large horizontal forces need to be transferred to the subsoil, combine with large vertical reactions whenever possible (**steep inclination** of resultant force)
- Bridge **piers are often stiff** compared to the foundation
 - modelling foundations as **infinitely stiff is inadequate**
- Appropriately modelling the stiffness of foundations is particularly relevant for
 - design of **slender piers** (buckling length)
 - **(semi-)integral bridges** (quantify restraint, position of movement centre, ...)
 - **seismic design**
- **The stiffness of spread footings** may be modelled using elastic springs at the pier base, see figure on this slide

Elastic stiffness of spread footings (for global structural analysis of bridge)

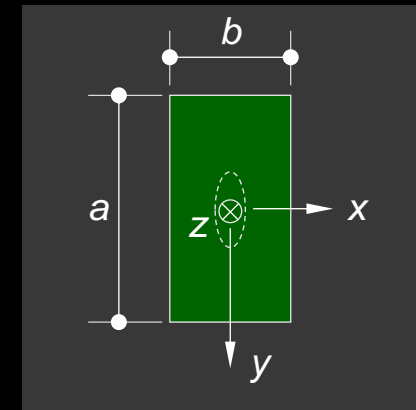
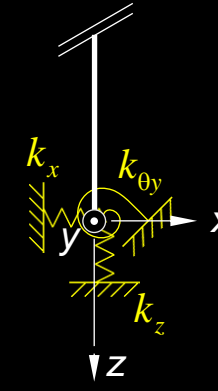
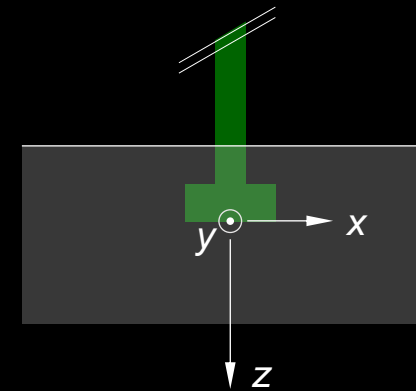

$$k_z \approx 1.25 \frac{M_e}{1-\nu^2} \sqrt{ab}$$

$$k_y = k_x \approx M_e \sqrt{ab}$$

$$k_{\theta y} \approx 0.25 \frac{M_e}{1-\nu^2} ab^2$$

$$k_{\theta x} \approx 0.25 \frac{M_e}{1-\nu^2} ba^2$$

Substructure – Foundations: Selected design aspects

General remarks and stiffness of pile foundations

- The modelling of pile foundations with elastic springs at the pier foot is not straightforward, as lateral movement and rotation are coupled
→ include pile foundations in global analysis model (piles with lateral and vertical elastic springs)
- Alternatively, the model illustrated in the figure can be used. The length l_f of the rigid bar and the stiffnesses are determined such that the surrogate model shown on the right side has the same global response as the pile foundation (displacements and rotations used to define l_f and the stiffnesses are determined from a separate model of the pile foundation).

For details on geotechnical design see lectures of IGT

Elastic springs+rigid bar model for stiffness of pile foundation
(for global structural analysis of bridge)

Pile foundation

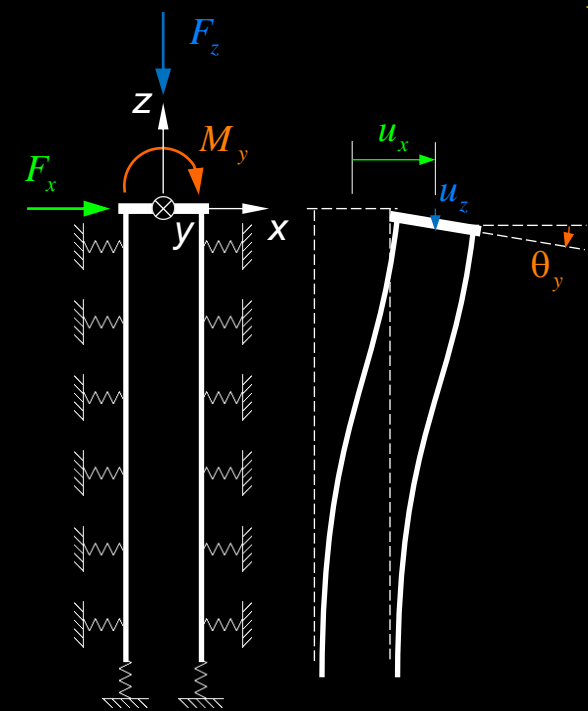

$$\begin{Bmatrix} F_x \\ M_y \\ F_z \end{Bmatrix} \rightarrow \begin{Bmatrix} u_x \\ \theta_y \\ u_z \end{Bmatrix} = \begin{Bmatrix} u_x(F_x) + u_x(M_y) \\ \theta_y(M_y) + \theta_y(F_x) \\ u_z(F) \end{Bmatrix}$$

Surrogate model

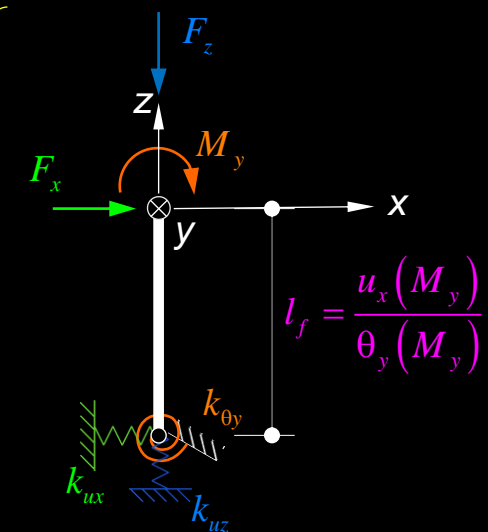

$$k_{ux} = \frac{F_x}{u_x(F_x) - \frac{\theta_y(F_x)}{\theta_y(M_y)} u_x(M_y)}$$

$$k_{\theta y} = \frac{M_y}{\theta_y(M_y)}$$

$$k_{uz} = \frac{F_z}{u_z}$$

Substructure

Foundations – Scour protection

Substructure – Foundations: Scour protection

Scour protection

If foundations are located in or near streams (rivers, creeks, tidal channels), erosion of the channel bed, known as **scour**, must be considered when designing the foundation.

Erosion may occur due to turbulence caused by the bridge piers and foundation (**local scour**, see figure), or larger scale effects.

Deep foundations, using shafts or piles, are effective measures to prevent scour damage.

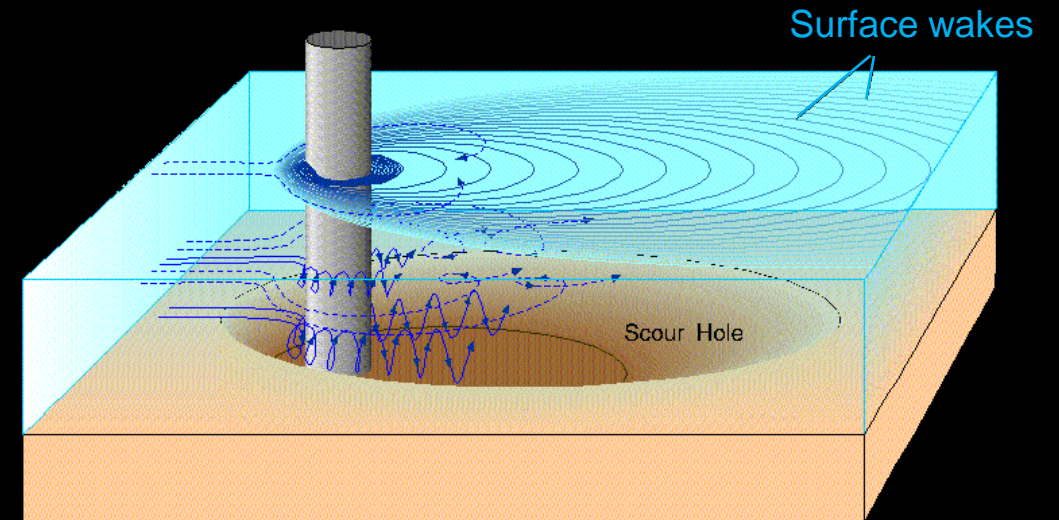

plan view

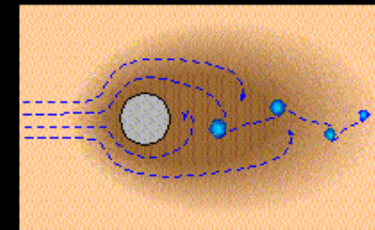

- Horseshoe vortex (Hufeisenwirbel)
- - - Wake vortex (Wirbelschleppe)

elevation

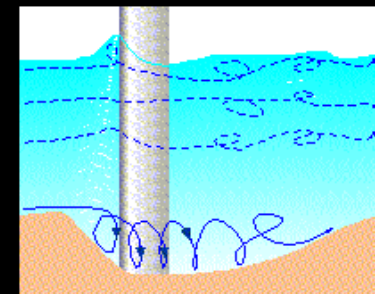

Substructure – Foundations: Scour protection

Scour protection

In spite of the general awareness of the issues related to scour, it remains **a notable cause of bridge failures**.

This may be due to the fact that the **foundation depths required for an effective scour protection may often appear excessive** at first glance. As an example, in the Chandoline bridge (figures), the foundations had to be located 25 m below the riverbed.

However, deep scour has been observed in many bridges, which justifies deep foundations in or near streams to avoid scour – as observed in the cases illustrated on the following slides.

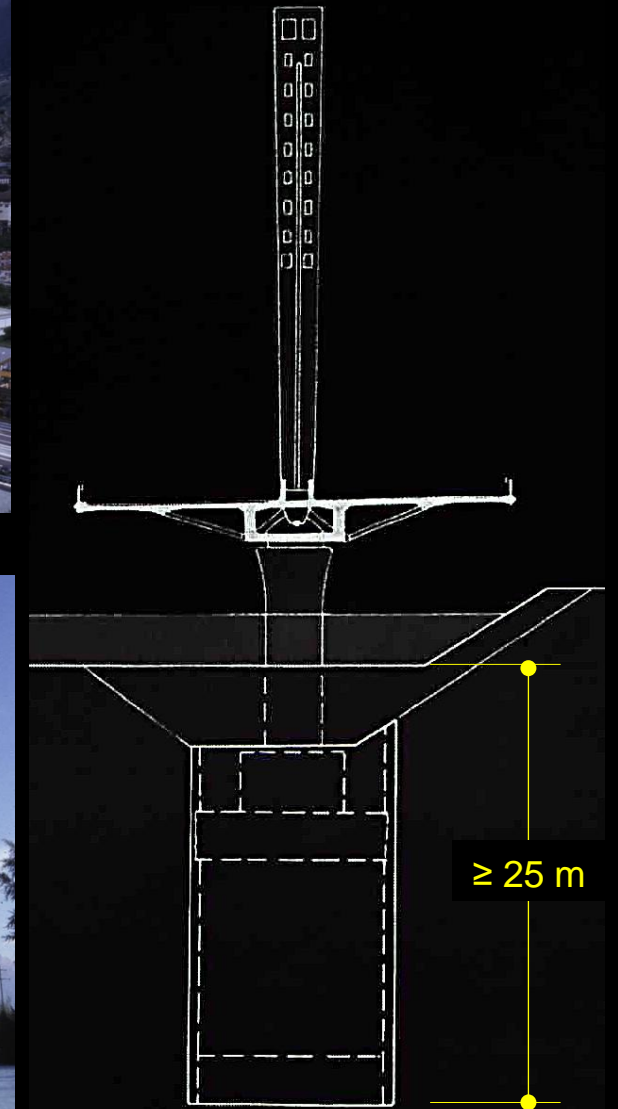

Substructure – Foundations: Scour protection

Scour protection

Flood events, particularly in alpine regions, where rivers and creeks change their beds, are a typical cause of damage due to scour.

The Reussbrücke Wassen (right), built 1972, was severely damaged due to scour in a flood event on the 24./25.8 1987. It could be repaired and is still used today, see lecture Stahlbeton I (rotation capacity)

A more recent example is the Hüscherabachbrücke near Splügen GR (below), damaged by scour in a flood event in June 2019.



Substructure – Foundations: Scour protection

Scour protection

A famous bridge affected by scour is the Sunnibergbrücke, whose foundations suffered severe scour in a flood event in 2005, while still closed to the public.

Since the large diameter pile foundation ensured sufficient resistance, only limited repair was required and the bridge could be opened as planned in 2006,



Substructure – Foundations: Scour protection

Scour protection

Historical bridges are often subject to scour, since the technology at the time of their construction did not allow as deep foundations as today (particularly no large diameter piles available). In such bridges, the **riverbed must be inspected** regularly.

As an example, in the Aarebrücke Koblenz, divers detected up to **9 m deep scour in the riverbed** after a flood event in 1999. A «concrete block carpet» was installed immediately for protection, and freight trains must not pass the bridge at speeds higher than 30 km/h since.

Currently, each pier is secured with a new pile cap sitting on four large diameter piles drilled to the solid rock (10...18 m below ground). At the same time, the piers are strengthened for horizontal forces.

