

Arch bridges

(Bogenbrücken)



Tamina bridge, Switzerland, 2016. Leonhardt, Andrä und Partner

$f/l = 1/5.3$



Tamina bridge, Switzerland, 2016. Leonhardt, Andrä und Partner

$$f/l = 1/5.3$$

Introduction

Historical perspective



Anti-funicularity



Typologies



Design

General considerations



Arch rib geometry



Bending moments in arch bridges



Design aspects specific to different arch typologies



Structural response of arch bridges



Erection methods

General remarks and centrings



Cantilever-constructed steel arches



The Melan System and related methods



Vertical assembly and rotation



Cantilever-constructed concrete arches



Evolution of the Melan System



Final remarks

Arch bridges

Introduction

Arch bridges

Introduction – Historical perspective and terminology

Arch bridges – Introduction: **Historical perspective**

- **Masonry arches**, and masonry arch bridges, have been built for centuries, or rather, millennia (photo)
 - analysis of arches was one of the first topics studied in the history of the theory of structures
 - da Vinci already studied and measured the horizontal thrust of arches
 - Coulomb was one of the pioneers, followed by many other (Monasterio, Culmann, Poleni, Heyman, ...) (figure)
- Since there is no tensile strength in the joints, masonry structures **act primarily in compression** → anti-funicular arch geometry (axis geometrically similar to funicular polygon of forces, i.e. corresponding to **thrust line = Druck-/Stützlinie**) is ideal.

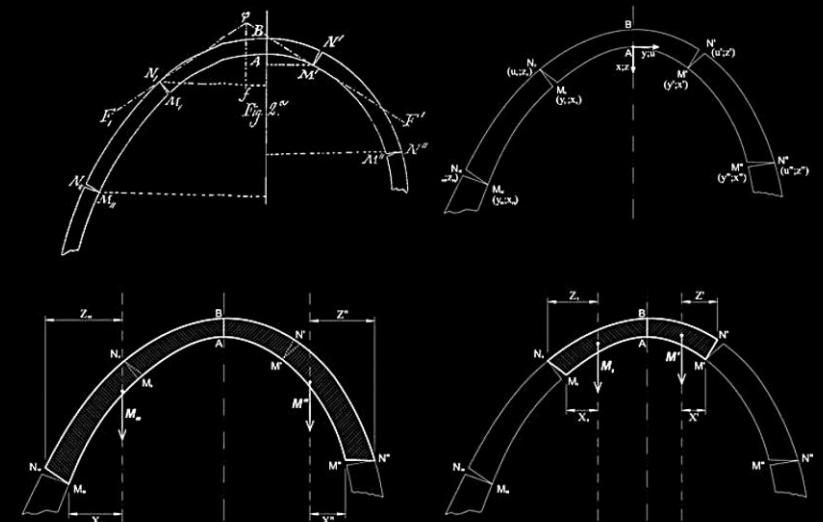

Arch bridges – Introduction: **Historical perspective**

- Masonry arch bridges are part of the **cultural heritage of our society and, more specifically, the Swiss railway network.**
- For example, the Albula and Bernina lines of RhB are UNESCO World Cultural Heritage, the consistent use of standardised stone masonry arch bridges being one of their main characteristics.



Arch bridges – Introduction: **Historical perspective**

- **Timber arches** have also been built for many centuries. Johannes Grubenmann was one of the pioneers (photo).
- About two centuries ago, **iron (photo), steel and concrete arches** became economical, significantly increasing the feasible spans.
- With its high compressive, but negligible tensile strength, **concrete is perfectly suited for arch bridges**.

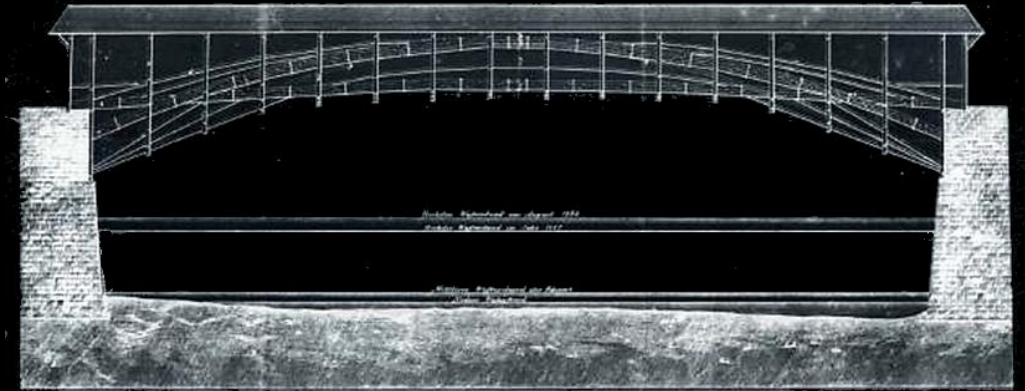

Arch bridges – Introduction: **Historical perspective**

- The first **concrete arch bridges** were mimicking masonry arches (unreinforced concrete used as inexpensive stone surrogate). More slender, efficient and elegant concrete arches emerged about a century ago (photo).
- Switzerland was at the forefront in these developments, mainly due to:
 - its **topography** with many steep valleys being well-suited for arch bridges
 - the early development of **cement production** (with very limited domestic steel production)
 - competent and innovative **structural engineers**
- The following **Swiss bridge designers** are internationally recognised as **pioneers in concrete arch bridge design**:
 - Robert Maillart
 - Alexandre Sarrasin
 - Christian Menn

The next slides show some of their most prominent bridges. For more examples, see respective presentation “Eminent bridge designer of the week”.



Arch bridges – Introduction: **Historical perspective**



Arch bridges – Introduction: **Historical perspective**



Arch bridges – Introduction: **Historical perspective**

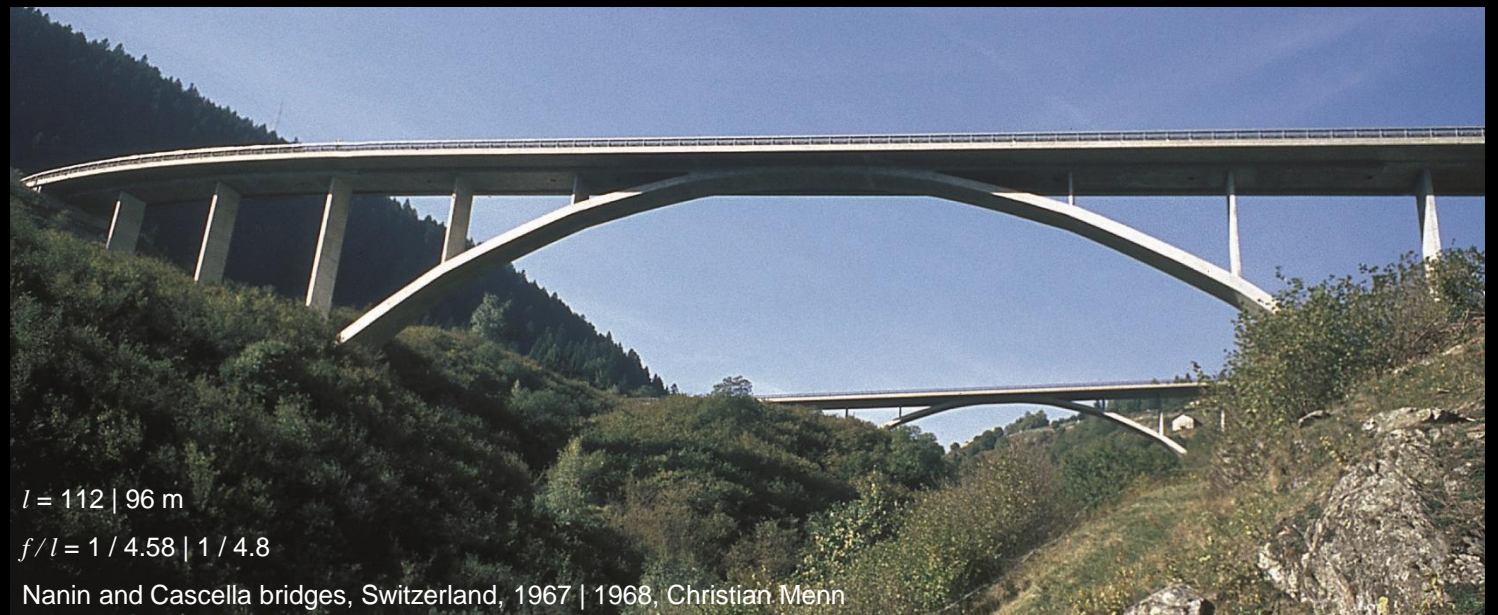

Arch bridges – Introduction: **Historical perspective**

- Of course, spectacular **concrete arch bridges** were also designed by designers in many other countries.
- As an example, the **Tara Bridge** (aka Đurđevića-Tara Bridge) designed by Mijat S. Trojanović, opened in 1940



Arch bridges – Introduction: **Historical perspective**

- Due to their high erection costs and the progress of more economical typologies (cantilever-constructed bridges for shorter, cable-stayed bridges for longer spans), only **few large arch bridges were built in the 2nd half of the 20th century.**
- The last three decades have, however, seen a **revival of long-span arch bridges**, driven by the development of **CFST-arches in China** (CFST = concrete-filled steel tube).
- Since the first CFST bridge with a moderate span of 115 m built in 1990 (Wanchang Bridge), more than 400 such arches were built.
- Currently, the **Third Pingnan Bridge** is the longest CFST arch @ 575 m span (2020, see photo, succeeding to the **Bosideng Bridge**, 2013 @ 530 m span, animated photo).



Arch bridges – Introduction: Terminology

An **arch bridge** essentially consists of three fundamental structural elements:

- **Arch rib** (or simply **arch**)
 - main structural element
 - ... supporting the deck
 - ... transferring the loads to the arch abutments
 - anti-funicular geometry for permanent loads (pure compression under these actions)
- **Deck girder** (or just deck / girder, all are commonly used for arches)
 - usually **continuous girder**, transferring its self-weight and the traffic loads to the spandrel columns or hangers
- **Spandrel columns or hangers**
 - structural elements connecting deck and arch, acting primarily in
 - ... compression (spandrel columns)
 - ... tension (hangers)

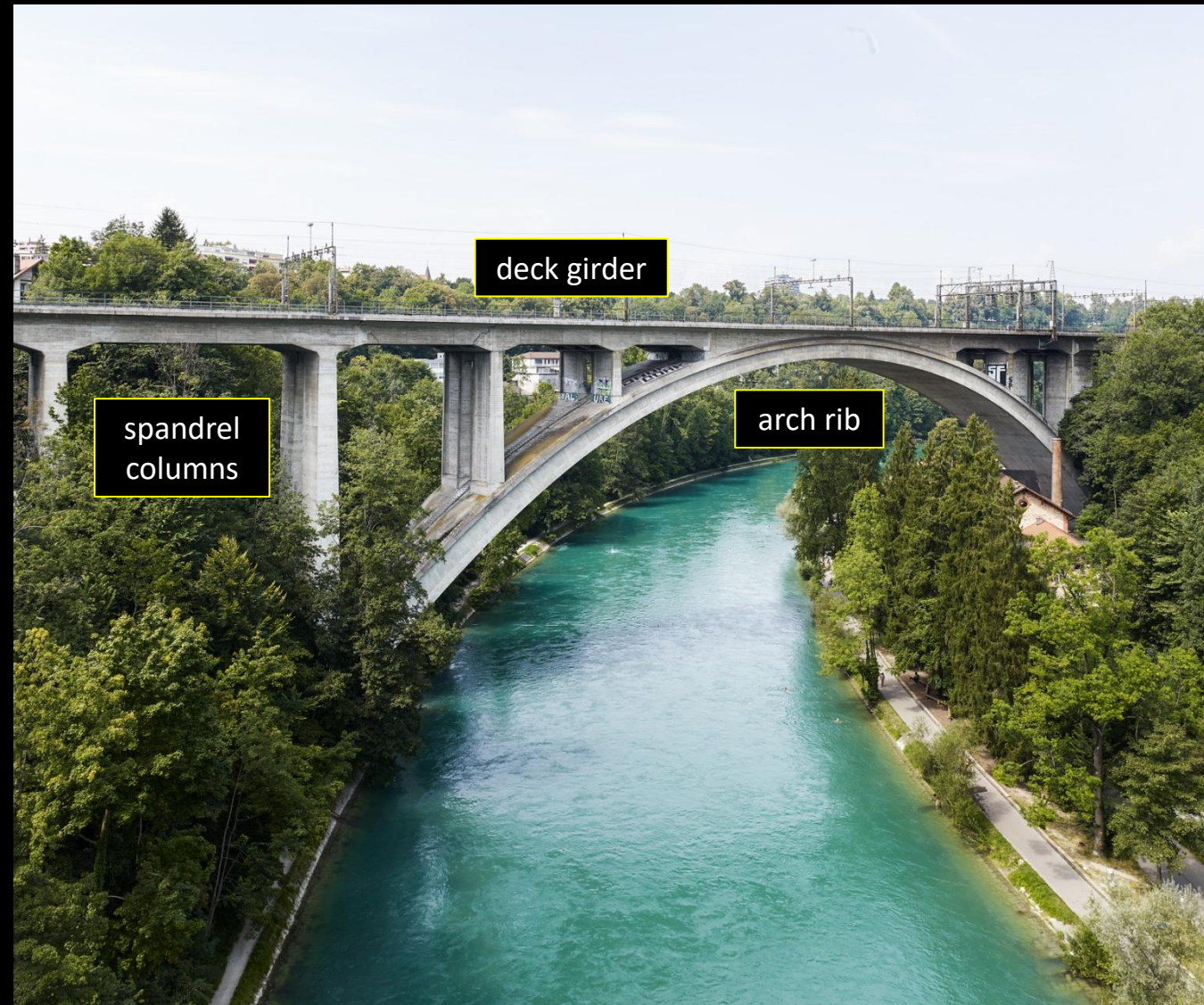

Arch bridges – Introduction: Terminology

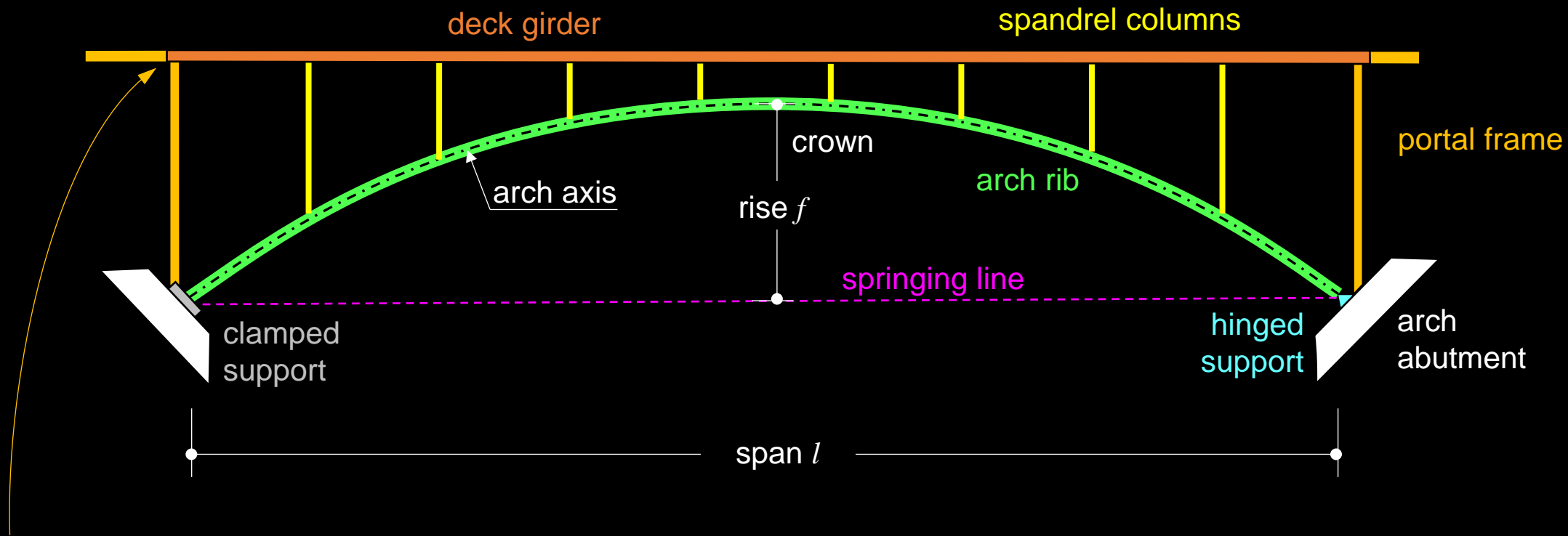

separation of deck girder above arch abutments (portal frames)
common in historical bridges, not adequate for modern bridge
design

Arch bridges

Introduction – **Anti-funicularity**

Arch bridges – Introduction: Anti-funicularity

- Arches are **highly efficient structures**, since they are able to **carry loads by “compression only”** – provided that the thrust line lies inside the arch cross-section.
→ the ability of arches to carry high loads is primarily **due to their shape**
- Structures whose **axis coincides with the thrust line** (i.e., is **geometrically similar to the funicular polygon**) under a certain load are **anti-funicular for that specific load**, i.e., they act in pure compression.
- Anti-funicular arches are thus **analogous to funicular structures** (latin funiculus = rope), but with **opposite sign** (compression instead of tension).
- In the analysis of masonry arches, and masonry structures in general, **graphic approaches are very useful** (see notes, figure and next slide).
- The **thrust line** shows the resultant of compression (in the example on the next slide, for traffic load on the right half of the span).

Parabolic arch under uniform load: Arch axis geometrically similar to funicular polygon, pure compression in arch

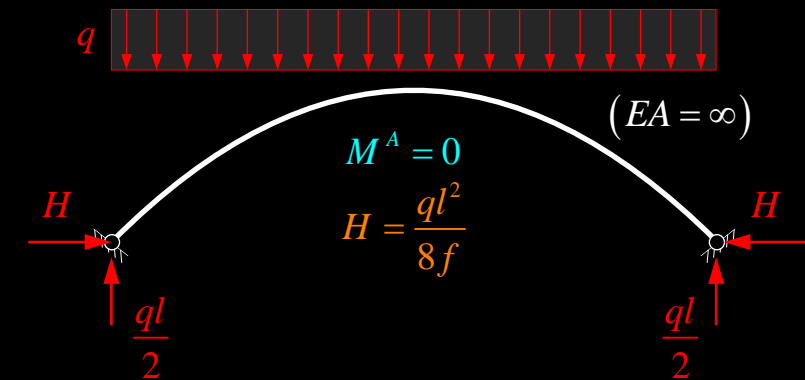

Culmann (1866): Explanation of arch thrust and support conditions

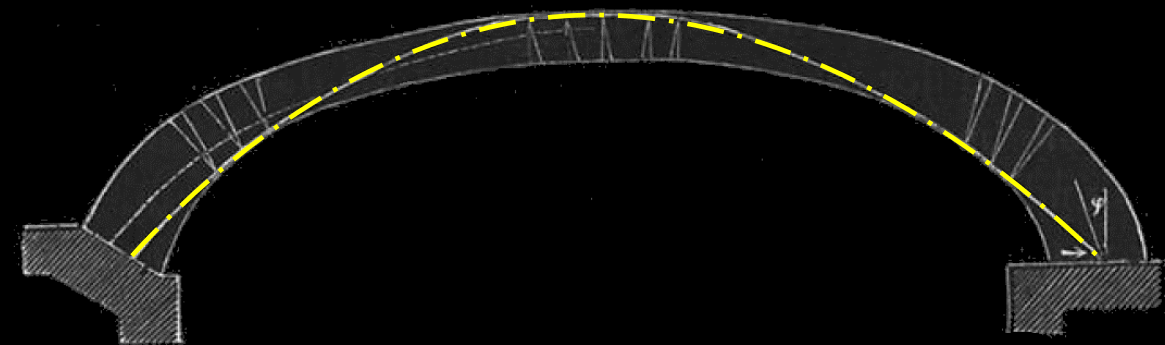

Arch bridges – Introduction: **Anti-funicularity**

- Most existing masonry viaducts, such as the Soliser Viadukt (clear span 42 m), were designed using graphical statics.

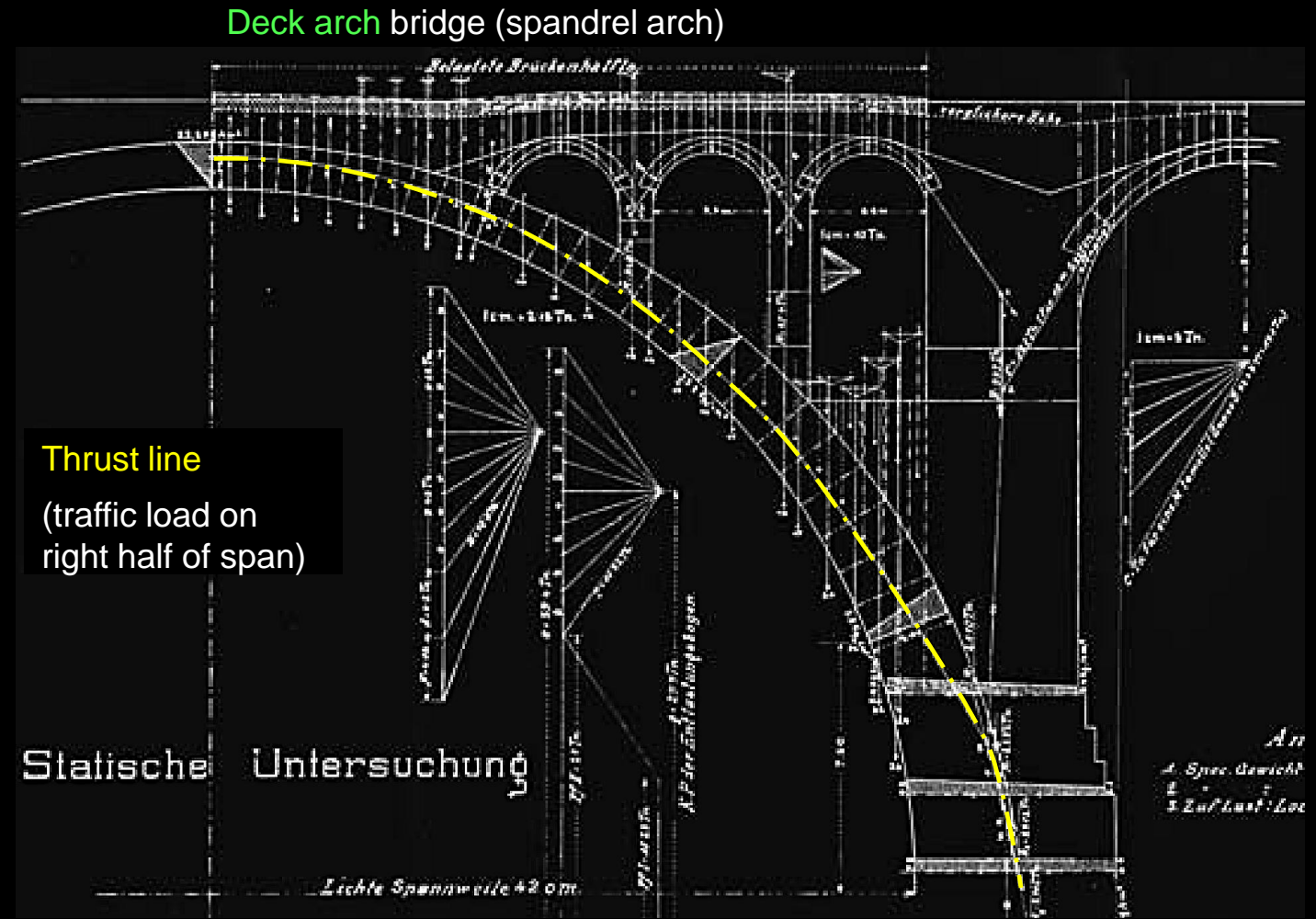
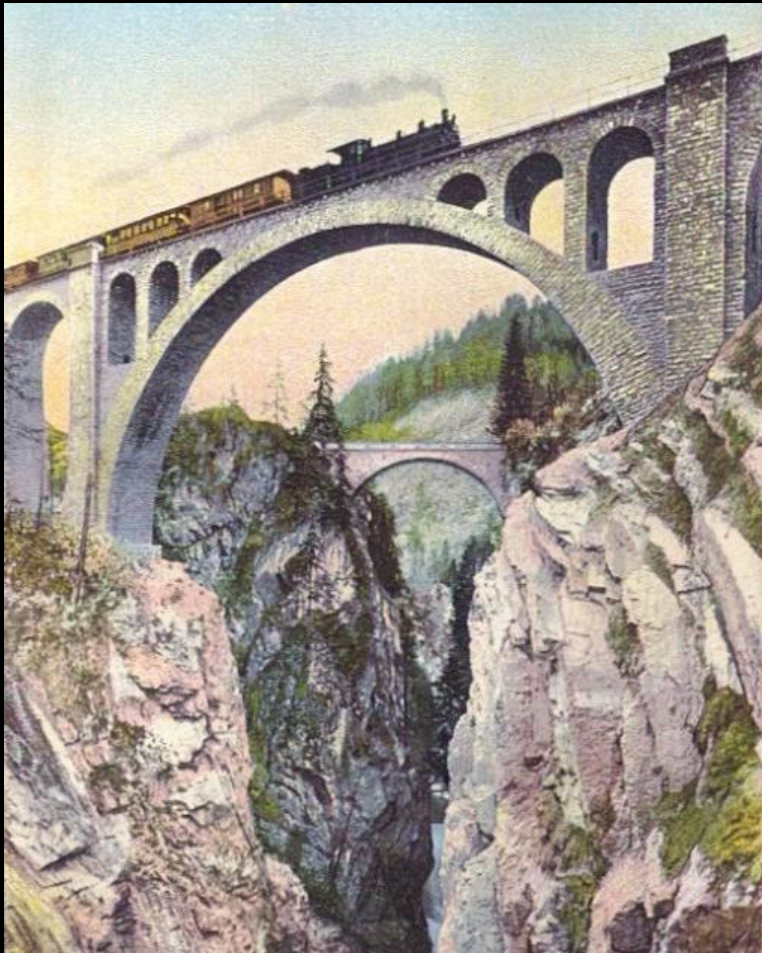

Arch bridges – Introduction: **Anti-funicularity**

- However, other than ropes and funicular structures in general, **arch ribs** (as anti-funicular structures for a specific load)

→ **do not adjust their shape** to varying configurations of applied loads

→ need to resist **arch bending moments** $M = e \cdot N = e_z \cdot H$ caused by loads causing deviations e (with vertical component e_z) of thrust line and arch axis

(M can be resisted jointly by arch and deck, see behind)

→ in any case require a **bending stiffness to prevent buckling** (even if globally stabilised by other elements, local buckling must be prevented)

Three-hinged arch and thrust line for half-sided load (illustration adapted from Marti, 2014)

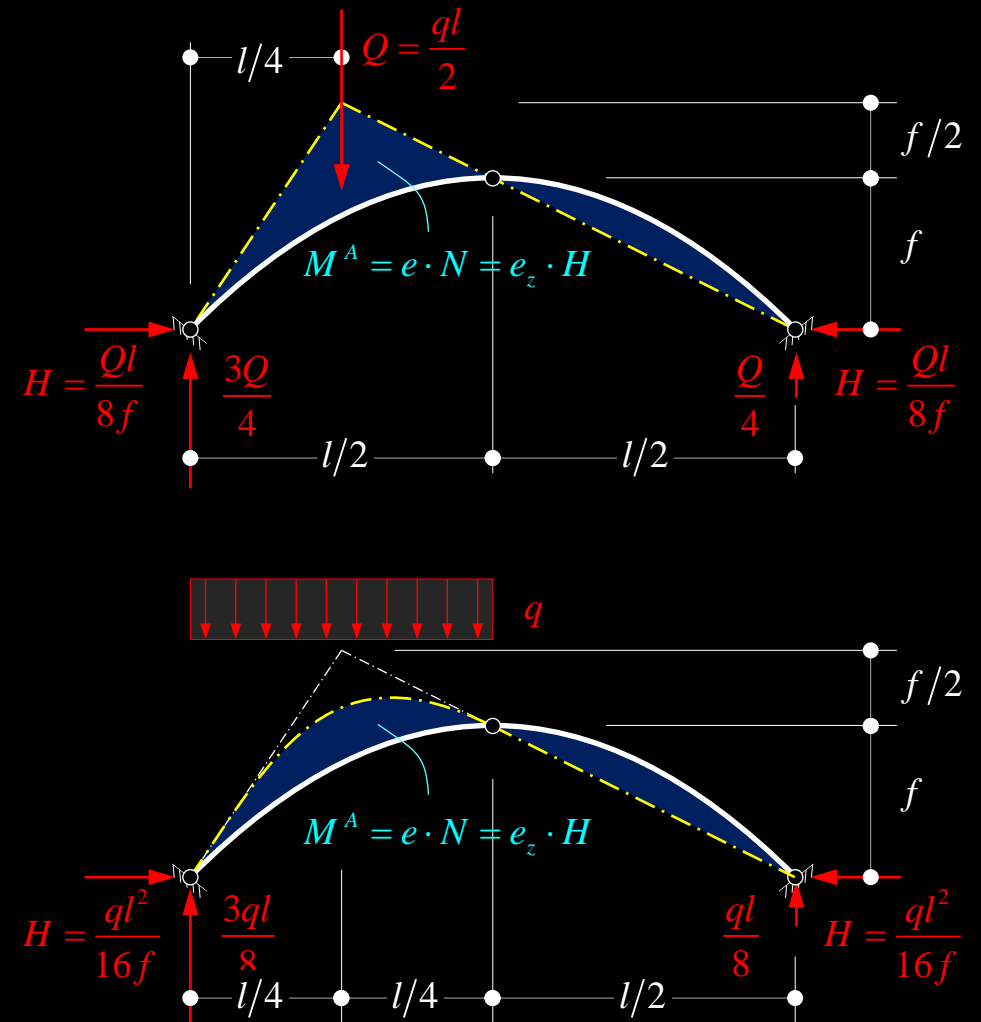

Arch bridges – Introduction: **Anti-funicularity**

- Any arch geometry is obviously **anti-funicular** for **one specific load configuration** only.
- All other loads need to be carried by bending**
 - of the arch itself (“stiff arch”), figures
 - of the deck girder (“deck-stiffened arch”)
 - of arch and deck girder combined (usual)
- In analysis, **applied loads can be divided** into loads causing pure **compression** (those for which the geometry was chosen) and loads causing pure **bending**, see figure.
- Self-weight is the dominant load** in bridges
 - the arch geometry should closely **match the thrust line under permanent loads**
 - arches are then still **very efficient** as they carry a large portion of the total loads in compression (figures)

Arch, anti-funicular for uniform load, under non-symmetrical load (illustration adapted from Marti, 2014)

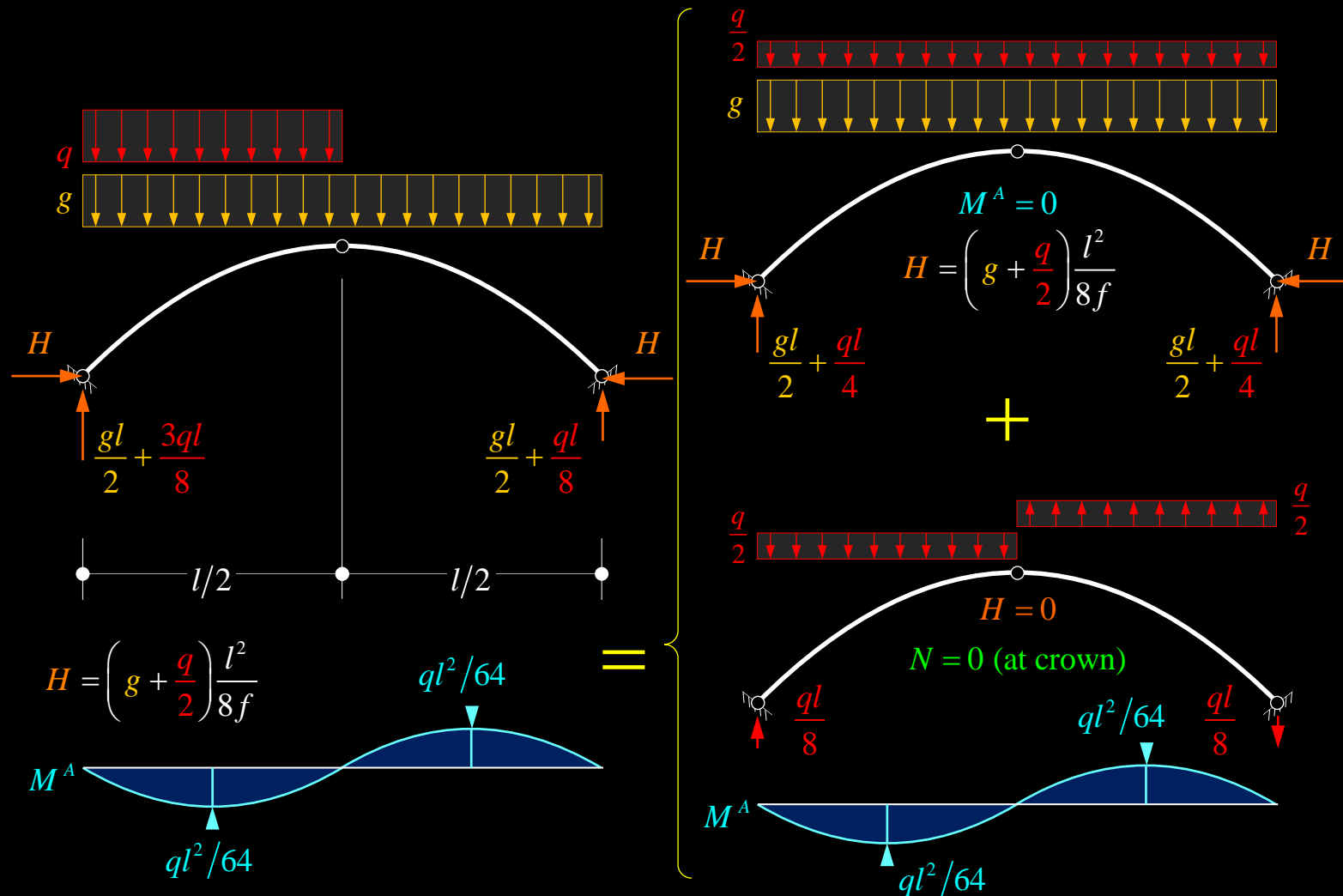

Arch bridges

Introduction – Typologies

Arch bridges – Introduction: **Typologies**

- The typology of arch bridges is commonly related to the **position of the deck with respect to the arch**.
- Accordingly, the following types of arches can be distinguished:
 - **Deck arch** bridge: deck above arch
 - **Tied arch** bridge: deck below arch (bowstring arch, “Langerscher Balken”)
 - **Through arch** bridge: deck and arch intersect (with or without connection)
- Each typology has its structural particularities, but with a common element: **The arch**.

Deck arch
bridge
(spandrel arch)

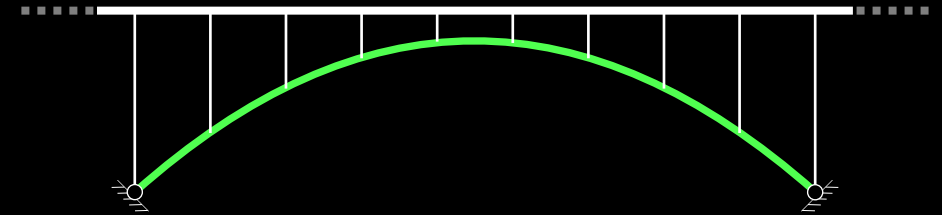

Tied arch bridge
(bowstring arch,
“Langer beam”)

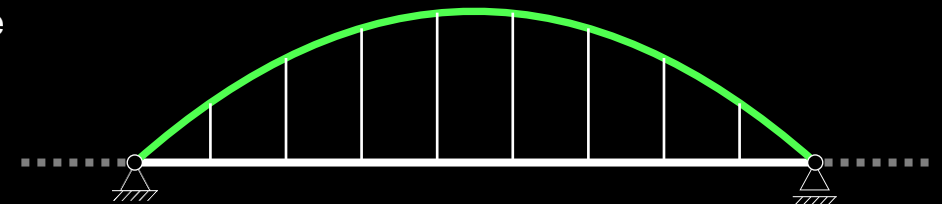

Through arch
bridges

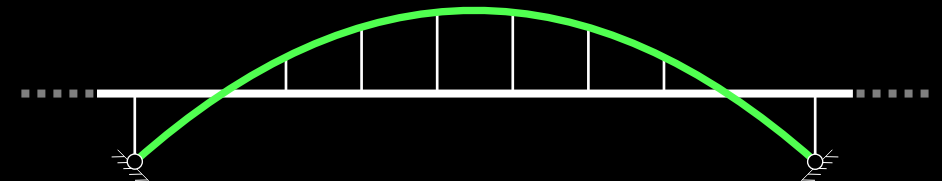

Arch bridges – Introduction: **Typologies**

- Structurally, it makes more sense to distinguish arch typologies **based on the way the arch thrust H** (horizontal component of arch normal force) **is resisted**.
- Arches are most efficient if the **arch thrust is carried by the ground** (“true arches”), which requires **stiff soil**
 - principle of **masonry arch bridges**
(note: high self-weight is beneficial for foundations as it reduces the inclination of the support reaction)
 - principle of **deck arch bridges**

Deck arch
bridge
(spandrel arch)

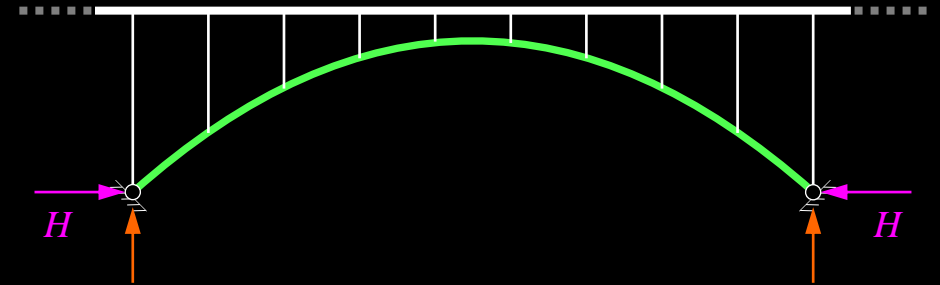

Arch bridges – Introduction: **Typologies**

Deck arch bridge

- Deck girder positioned at top of arch
- Arch supports deck via **spandrel columns**
- **Solid-spandrel arches** or **trussed arches** are also used (figures)
- **Full arch thrust** transferred to arch abutments



Zuoz bridge, Switzerland, 1901. Robert Maillart



Isorno rail viaduct, Switzerland, 1923. Löhle & Kern

Arch bridge – Introduction: **Typologies**

Deck arch bridge example

- Reinforced concrete
- Clamped arches
- $l = 390$ and 244 m
- $f/l = 1 / 5.82$ and $1 / 4.47$

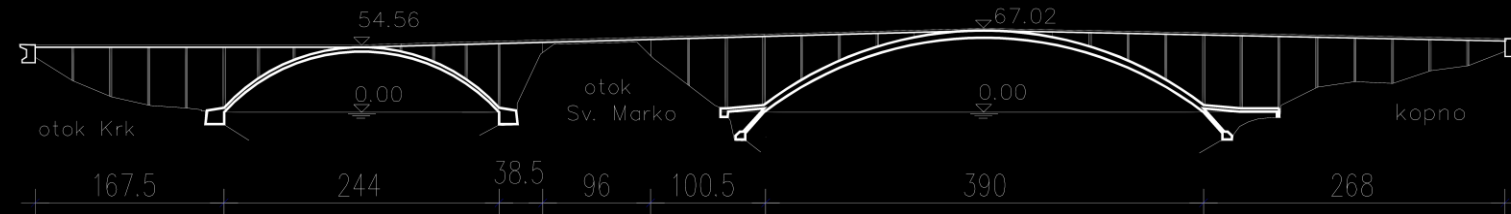

Krk bridges, Croatia, 1980. Ilija Stojadinović

Arch bridges – Introduction: **Typologies**

- Structurally, it makes more sense to distinguish arch typologies **based on the way the arch thrust H** (horizontal component of arch normal force) **is resisted**.
- Arches are most efficient if the arch thrust is carried by the ground (“true arches”), which requires stiff soil
 - principle of masonry arch bridges (note: high self-weight is beneficial for foundations as it reduces the inclination of the support reaction)
 - principle of deck arch bridges
- Alternatively, the **arch thrust** can be resisted by a **tension member** connecting the supports (along springing line)
 - **structurally less efficient**, since arch thrust must be resisted in tension
 - principle of **tied arch bridges**:
 - ... deck = tension member (more efficient) or
 - ... separate tension member parallel to deck (less efficient)
 - **externally**, a tied arch is a **simply supported beam**

Deck arch bridge (spandrel arch)

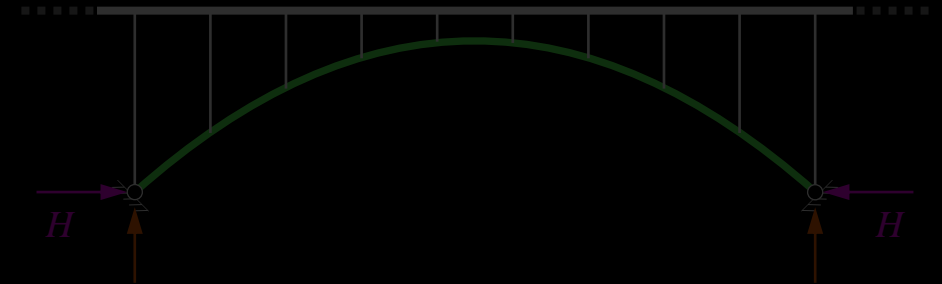

Tied arch bridge (bowstring arch, “Langer beam”)

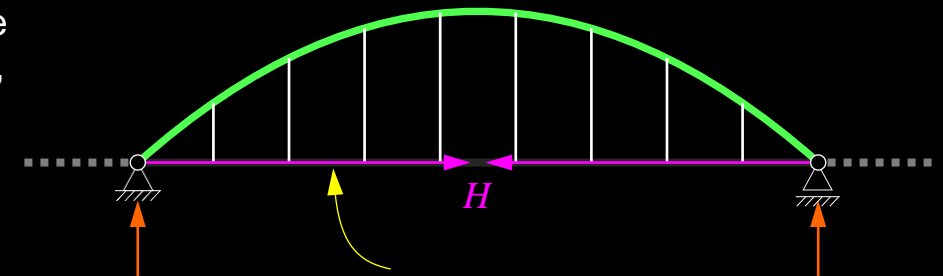

tension member = bridge girder / deck or separate element

Arch bridge – Introduction: **Typologies**

Tied arch bridge:

- Arch positioned above deck
- Deck suspended by arch via hangers
- **Arch thrust fully resisted by deck**
(→“externally”, it is a simply supported beam)
- Known in German speaking countries as Langer beam (**Langerscher Balken**) or “versteifter Stabbogen”



Puente sobre el río Guadalete, Barca de la Florida (near Jerez de la Frontera), M. Martínez, 1926.

Arch bridge – Introduction: **Typologies**

Tied arch bridge example

- Steel arch
- Simply supported (arch + deck = “girder”)
- $l = 168$ m
- $f/l = 1 / 5.60$

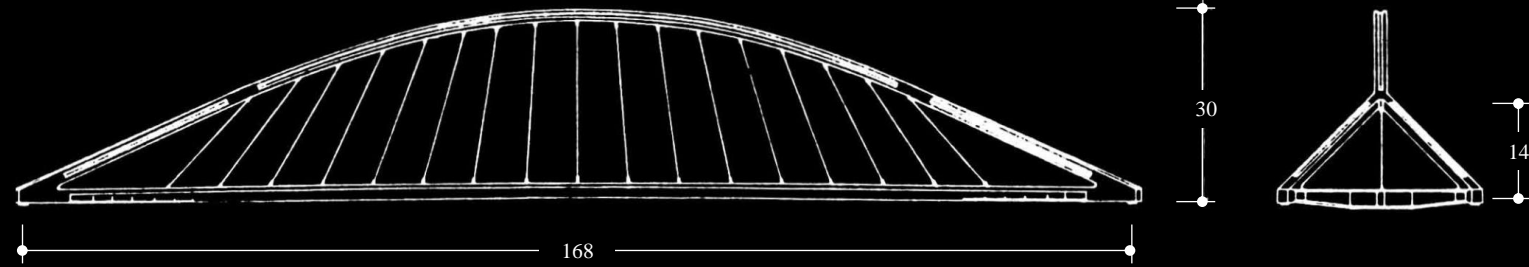

Barqueta bridge, Sevilla, Spain, 1992. J.J. Arenas and M.J. Pantaleón

Arch bridges – Introduction: Typologies

- In **through arch bridges**, the thrust may be resisted
 - by the foundations as in a **deck arch (true arch)**
 - by a **tension member** connecting the supports as in a **tied arch**
- If the **thrust is resisted by the foundations** (true arch, upper figures), the structural system corresponds to a **deck arch**, with the following aspects to be considered:
 - **arch must pass deck** without transferring longitudinal forces
 - **mix of hangers+spandrel columns** (different stiffness)
- If the thrust is resisted by the deck, different layouts are possible (bottom figures):
 - **through arch with struts transferring thrust to deck**
 - **tied arch supported on cantilevered structure**

In either case, such through arches are significantly more complex in design and construction than deck or tied arches.

- The structural concept of through arches is often hard to identify: They **lack the logic of form** other arches

Through arch bridges

... functioning as true arch

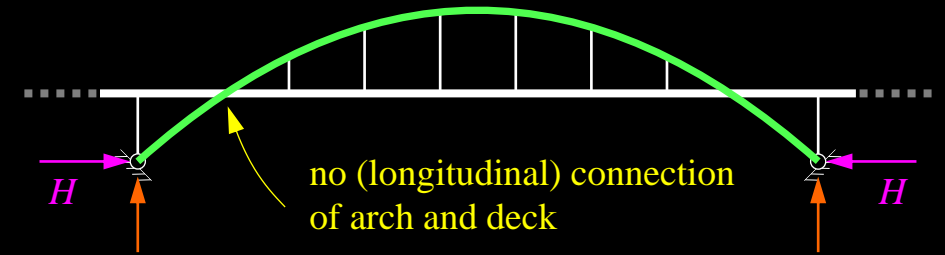

... as true arch with side span on inclined pier

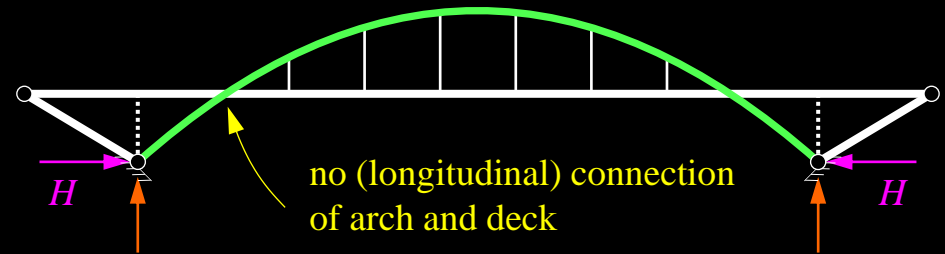

... as through arch with struts connecting arch and deck horizontally

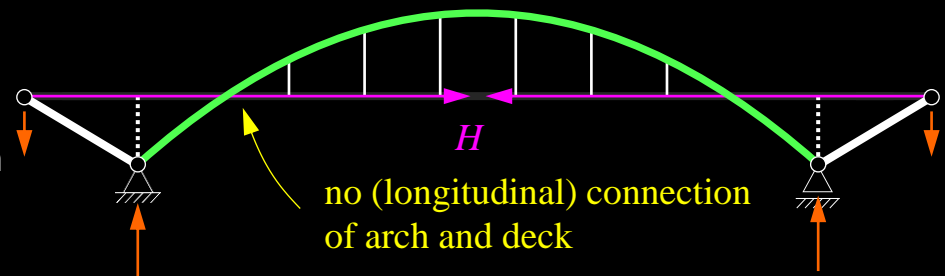

... as tied arch supported on V-struts

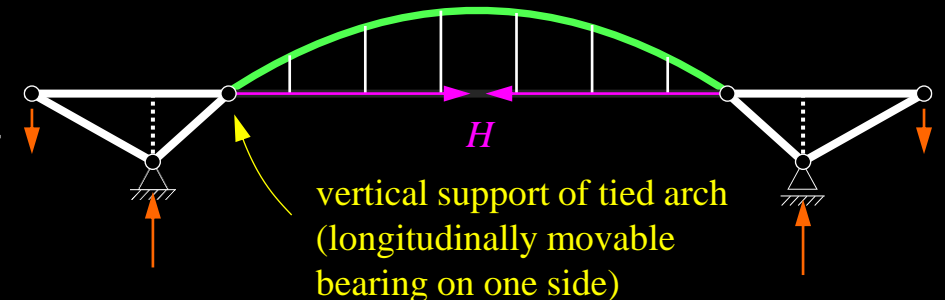

Arch bridge – Introduction: **Typologies**

Through arch bridge:

- Deck and arch overlap in elevation
- Midspan part suspended from arch via **hangers**, side spans supported by **spandrel columns** (if required)
- **Arch thrust** resisted by
 - ... **foundation** (= true arch) or
 - ... **deck** (= tied arch) or
 - ... **both** depending on stiffnesses (deliacte to quantify)



Tardis bridge, Mastrils-Landquart, Switzerland, 2003. dsp Ingenieure + Planer



Waal bridge, Netherlands, 1936.

Arch bridge – Introduction: **Typologies**

Through arch bridge example

- Steel arch
- Clamped **true through arch**
- $l = 329 \text{ m}$
- $f/l = 1 / 4.7$



Theodore Roosevelt lake bridge, Arizona, USA, 1990. Howard, Needles, Tammen & Bergendoff

Arch bridge – Introduction: **Typologies**

Through arch bridge example

- Steel arch on concrete V-struts
- **Tied through arch**
- $l = 420 \text{ m}$
- $f/l = 1 / 4.4$

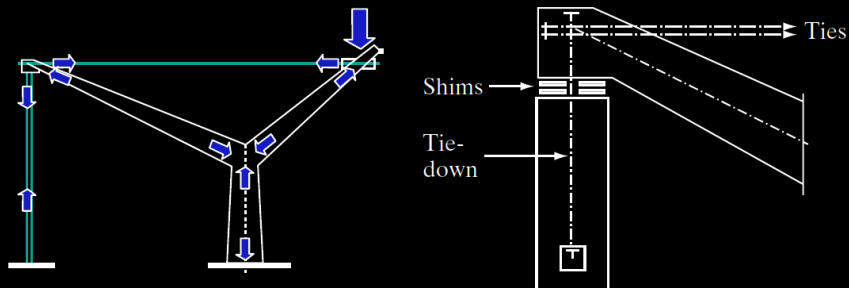
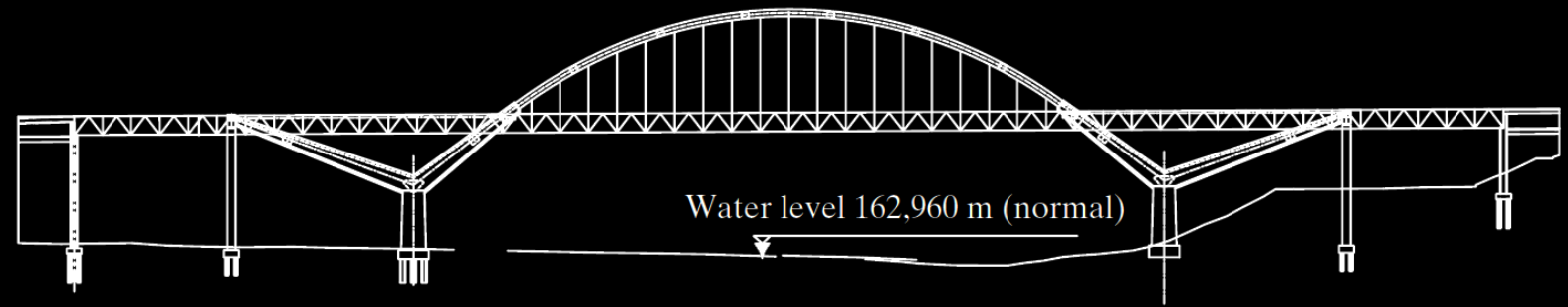

Chongqing Caiyuanba Bridge, China, 2007. Chongqing Communications Research & Design Institute / T.Y. Lin International

Arch bridge – Introduction: **Typologies**

Slender tied arches are sometimes termed “**hybrid arch bridges**“.
However, while the solutions are attractive, this **term is technically ill-founded**, see structural response).

(in any arch bridge, arch and deck share the applied loads (arch in bending and arch action, girder in bending). In flat arches, the deck simply carries a larger portion of the applied loads).

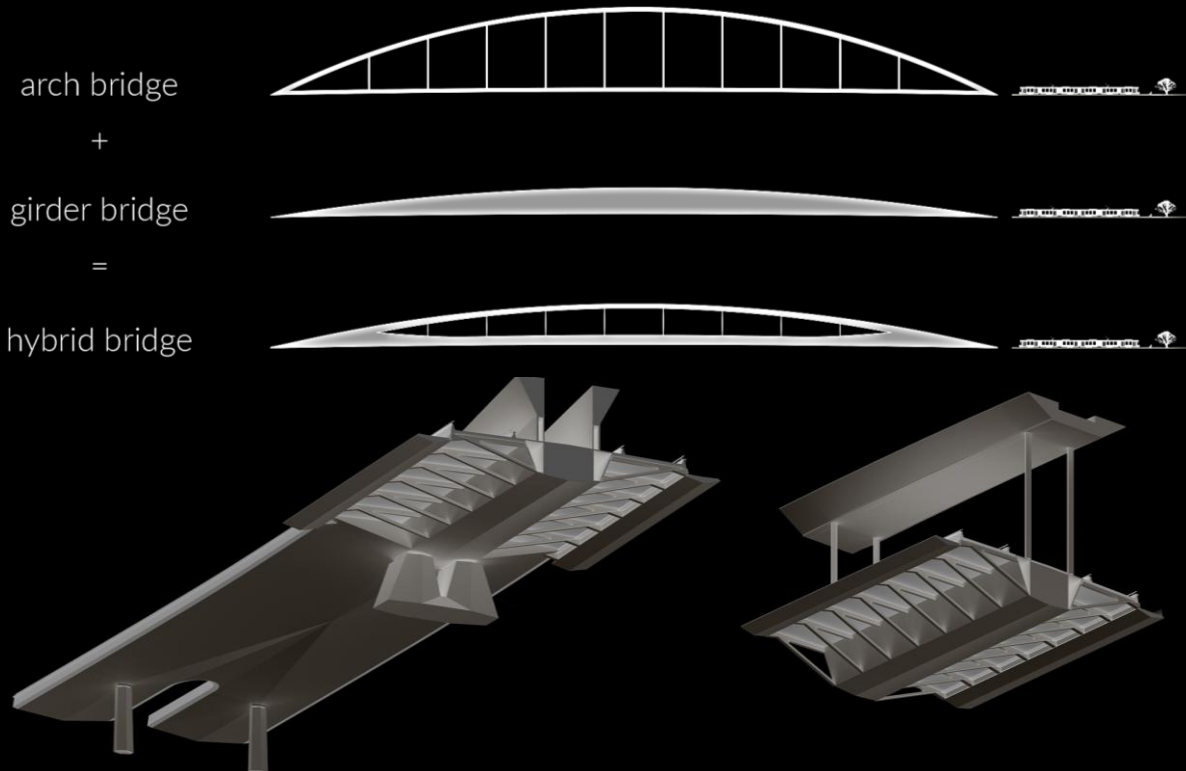

Tender design: Bridge over Danube River, Hungary, 2018. Fhecor Ingenieros

Introduction

Historical perspective



Anti-funicularity



Typologies



Design

General considerations



Arch rib geometry



Bending moments in arch bridges



Design aspects specific to different arch typologies



Structural response of arch bridges



Erection methods

General remarks and centrings



Cantilever-constructed steel arches



The Melan System and related methods



Vertical assembly and rotation



Cantilever-constructed concrete arches



Evolution of the Melan System



Final remarks

Arch bridges

Design

Arch bridges

Design – General considerations

Arch bridges – Design: **General considerations**

- Arches are **very efficient structures in their final configuration**, but
 - arch action is **only activated at closure**
 - arch **centrings are expensive** (tailor-made falsework and formwork)
 - **efficient erection methods** – important in any structure – are particularly important in arches
- Arch bridges built by cantilevering are considered **economical for spans $100\text{ m} \leq l \leq 300\text{ m}$** (200 m for concrete arches)
 - for **shorter spans**, **girders** are more economical (cost of arch is not compensated by savings in the deck girder)
 - for **longer spans**, **cable-stayed bridges** are more economical due to the efficient erection method
 - longer spans may be economical if an **optimised erection method** is used (e.g. CFST arches, see erection methods)
- **Other reasons, particularly aesthetical considerations, may still justify arch bridges**



Arch bridges – Design: General considerations

Material cost vs erection method

- The figures compare **different materials for conventional short span structures** (no complicated falsework for concrete, nor large cranes for steel and timber)
 - the load-deformation characteristics of **compression members costing 100 CHF/m**
 - the **total cost of an arch** for two rise-to-span ratios
- The **concrete compression members** are significantly stiffer and stronger at the same cost.
- Even for very large spans, and using normal strength concrete, **concrete is by far the most economical material in the final configuration** due to its low cost and high compressive strength (despite the better weight/strength ratio of steel and timber, which could be improved for concrete using high-strength concrete).
- However, **falsework for long-span arches is very expensive**
 - concrete arches built on **conventional scaffold** are only economical for **short spans**
 - unless efficient arch construction methods are used, **steel arches are thus more economical for medium-large spans**

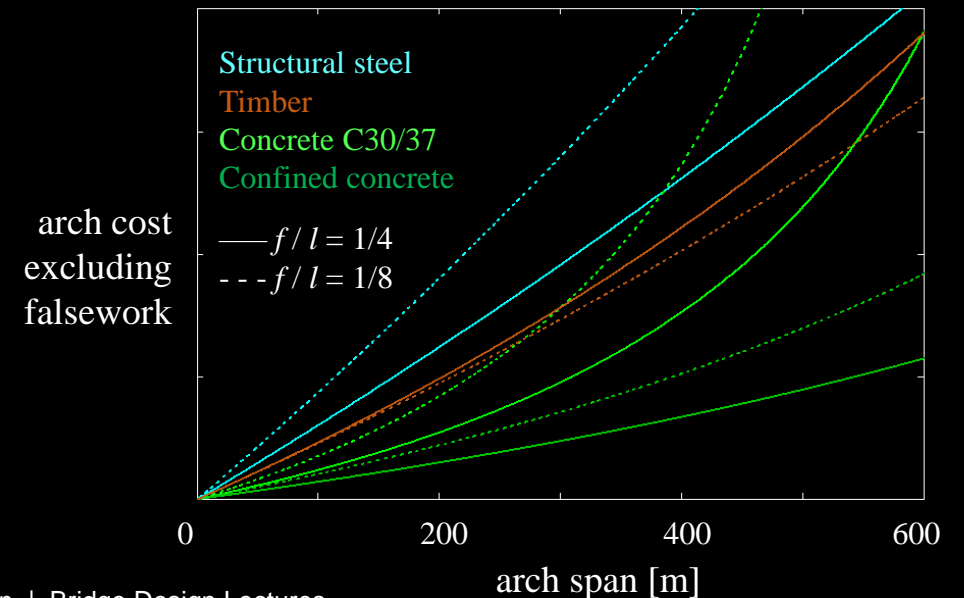
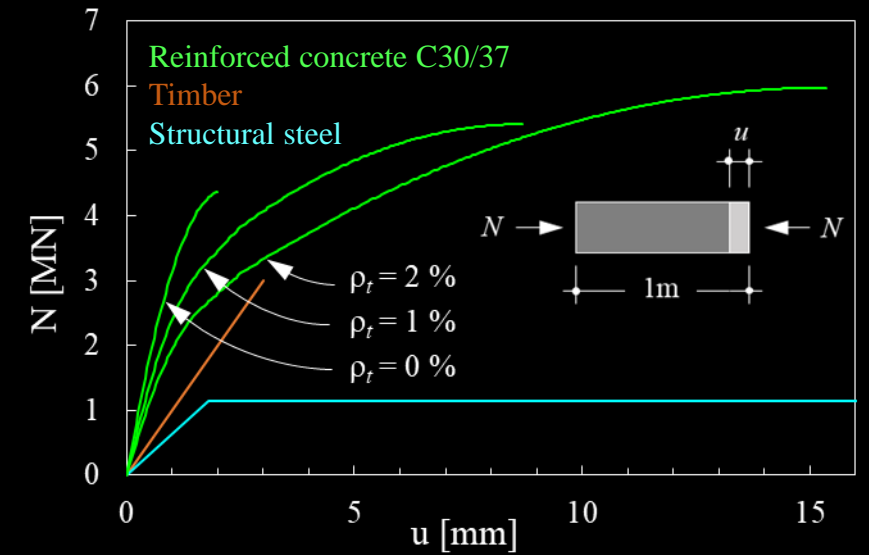

Arch bridges – Design: **General considerations**

- An example of a bridge where higher cost of an arch bridges was justified by the **superior aesthetics quality** and where **a steel truss arch was more economical than a concrete arch** (lighter weight = erection by stayed cantilevering of the arch possible, see erection methods – is the **New River Gorge Bridge** (1977, record span arch bridge until 2012).

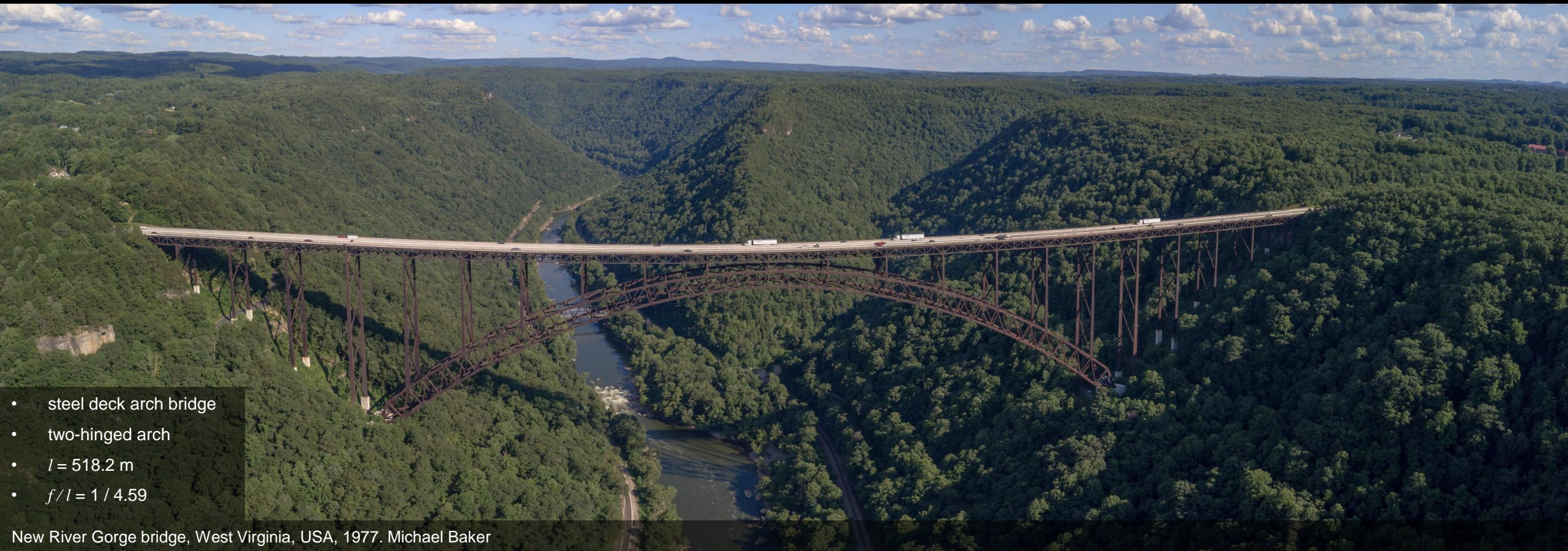

- steel deck arch bridge
- two-hinged arch
- $l = 518.2 \text{ m}$
- $f/l = 1 / 4.59$

New River Gorge bridge, West Virginia, USA, 1977. Michael Baker

Arch bridges – Design: **General considerations**

Deck arch bridges (and true arch through arch bridges) transfer important **horizontal forces** – the **arch thrust** – to the foundations, which is **the most efficient solution**. However

- the viability of **deck arch bridges** depends on the **soil conditions**
- the arch thrust increases with decreasing rise-to-span ratios f/l
- Long span and slender arches require **solid rock at the arch abutments**

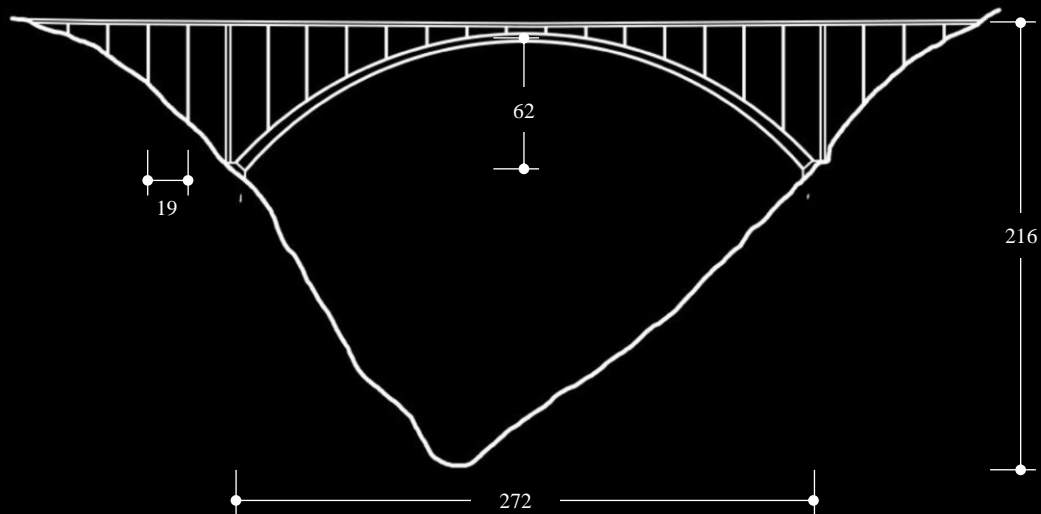

“Perfect” site for deck arch bridge:

- **strong soil (solid rock)**
- **steep valley**
- **relatively large span**

Arch bridges – Design: **General considerations**

- If true arch bridges are built in inadequate sites (soft soil, unstable slopes), consequences may be drastic.
- This is particularly due to their **sensitivity to (horizontal) movements** of the arch abutments
 - horizontal movements of the arch abutments cause changes in the horizontal reaction = deviations of the thrust line and corresponding **bending moments** along the arch
 - the importance of these effects depends on the magnitude of the movements and the rise-to-span ratio f/l (see structural response).

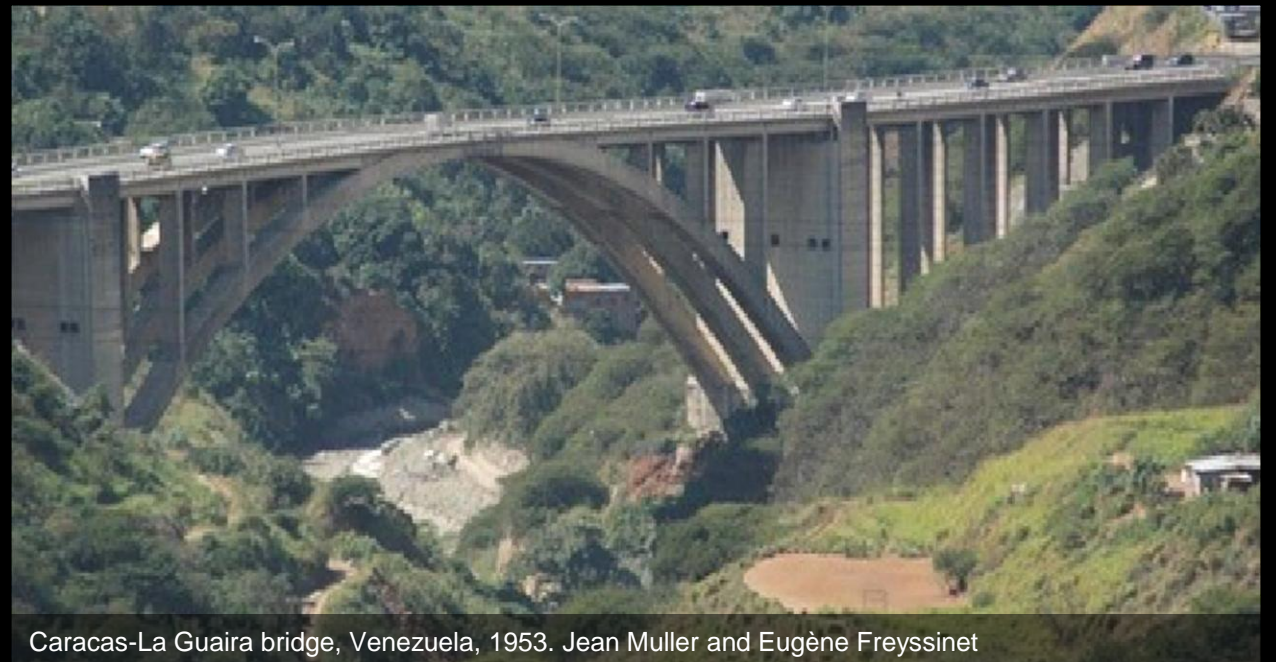
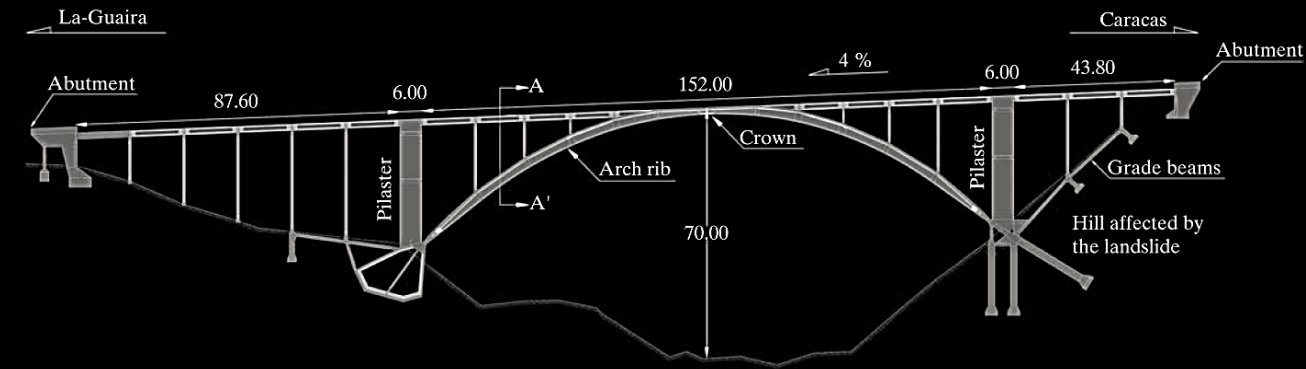

Caracas-La Guaira bridge, Venezuela, 1953. Jean Muller and Eugène Freyssinet



Arch bridges – Design: **General considerations**

- **Tied arch bridges**, on the contrary, are **simply supported girders “externally”** (the deck girder acts as tension member = tie, only vertical reactions under gravity load)
 - **suitable for locations with soft soil**
 - generally worth considering in **single-span bridges** (more transparent than simply supported standard girder bridges)
 - generally appropriate for single-span bridges with low clearance above traffic lines
 - **particularly suitable for bridges spanning rivers** where often the following conditions apply:
 - ... low clearance above flood level
 - ... no piers in river possible
 - ... soft soil layers to considerable depth
- The **elements connecting deck and arch** are often pin-jointed, acting in pure tension
 - referred to as **“hangers”** (even if they carry bending moments, see design)

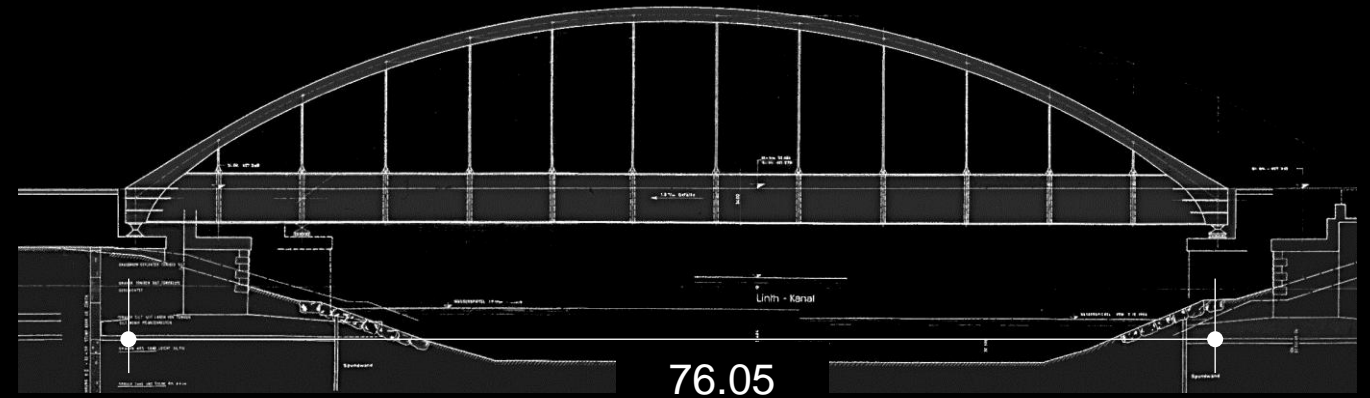

Arch bridges – Design: **General considerations**

Materials

- Concrete
- Steel
- Composite
- Timber
- ...

Shape

- Single arch
- Double arch
(in cross-section)
- Straight in plan
- Curved in plan
- Polygonal in plan
- Spatial arch
- ...

Cross section of the arch rib(s)

(constant or depth and/or width increasing towards abutments)

- Box
- Solid rectangular
- Tubular
- Truss
- ...

Cross section of the deck (usually constant)

- Box
- Slab
- T or double T
- ...

Geometry of hangers / spandrel columns

- Number
- Inclination
- Hinges at top and/or bottom

Hinges in the arch rib

- Clamped (“zero-hinge”) arch
- Two-hinged arch
- Three-hinged arch

Rise-span ratio f/l

- High arch $f/l \approx 1/2$
- Standard arch $f/l \approx 1/6$
- Low arch $f/l < 1/10$

Distributions of rigidities

- Stiff arch – flexible deck
- Flexible arch – stiff deck
- Intermediate solutions

Arch bridges

Design – Arch rib geometry

Arch bridges – Design: Arch rib geometry

- Most of the following slides show deck arches, but they **equally apply to tied arches** unless indicated otherwise.
- The **arch axis** should closely correspond to the **thrust line due to permanent load**, such that no bending moments are caused by this (usually most important) action
 - arch geometry geometrically similar to **funicular polygon of permanent loads**
- The **arch** is not uniformly loaded, but rather, **receives most loads via the spandrel columns**
 - “classic” **curved arch reasonably anti-funicular only for closely spaced columns** (8...10 over span)
 - if fewer spandrel columns or hangers are provided, a **polygonal arch geometry** should be chosen

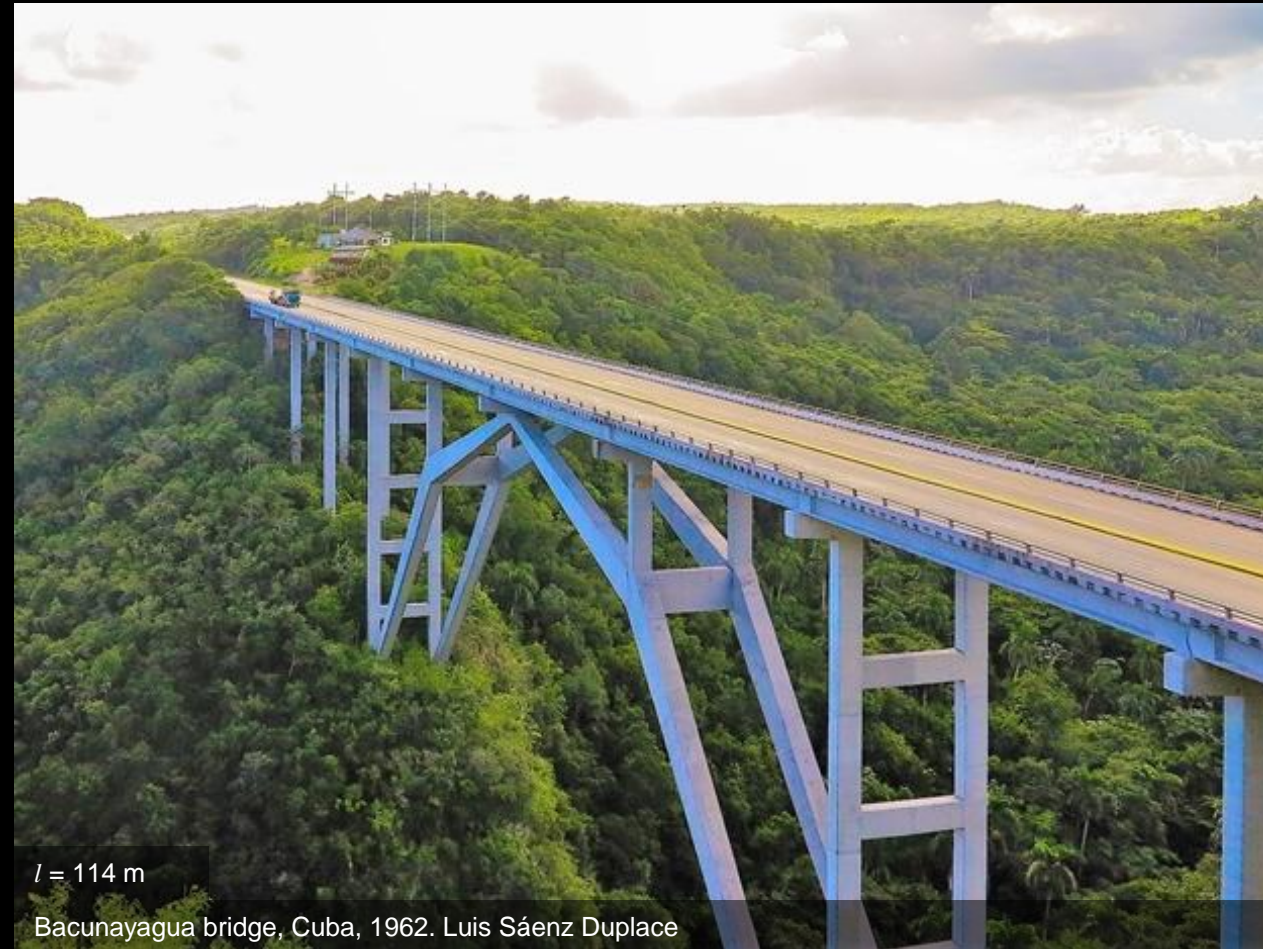
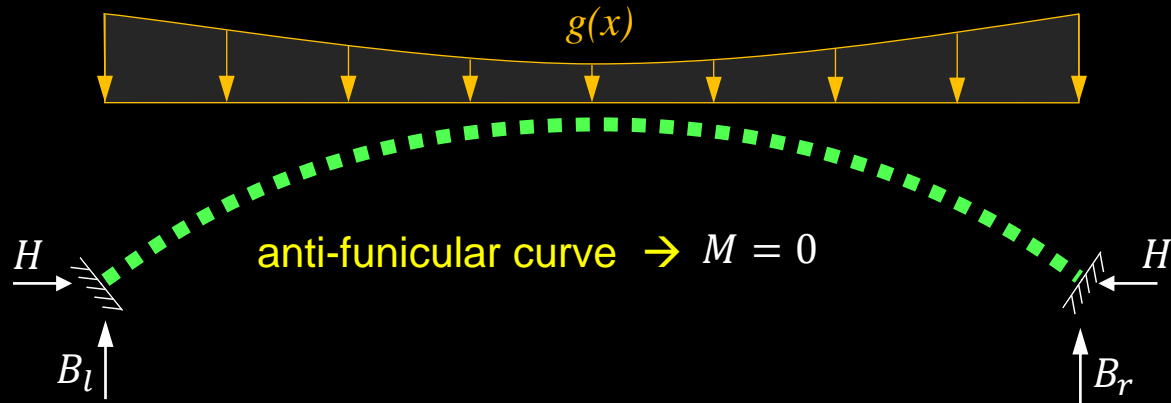

Arch bridges – Design: Arch rib geometry

Determination of the geometry of the arch

- The analytical equation to determine the anti-funicular geometry for a given load $g(x)$ is a **2nd order ordinary differential equation** (see figure).
- The **arch thrust H** (horizontal component of arch normal force) is constant if only vertical loads act.
- For any value of the **arch thrust $H > 0$** , (positive H = compression in arch rib), an anti-funicular geometry is obtained (all are geometrically similar):
 - **small $H \leftrightarrow$ large rise f** (high arch)
 - **large $H \leftrightarrow$ small rise f** (low arch)
- If the arch axis (centre of gravity of the arch rib) coincides with the resulting curve, the load $g(x)$ causes **pure compression in the arch rib**.

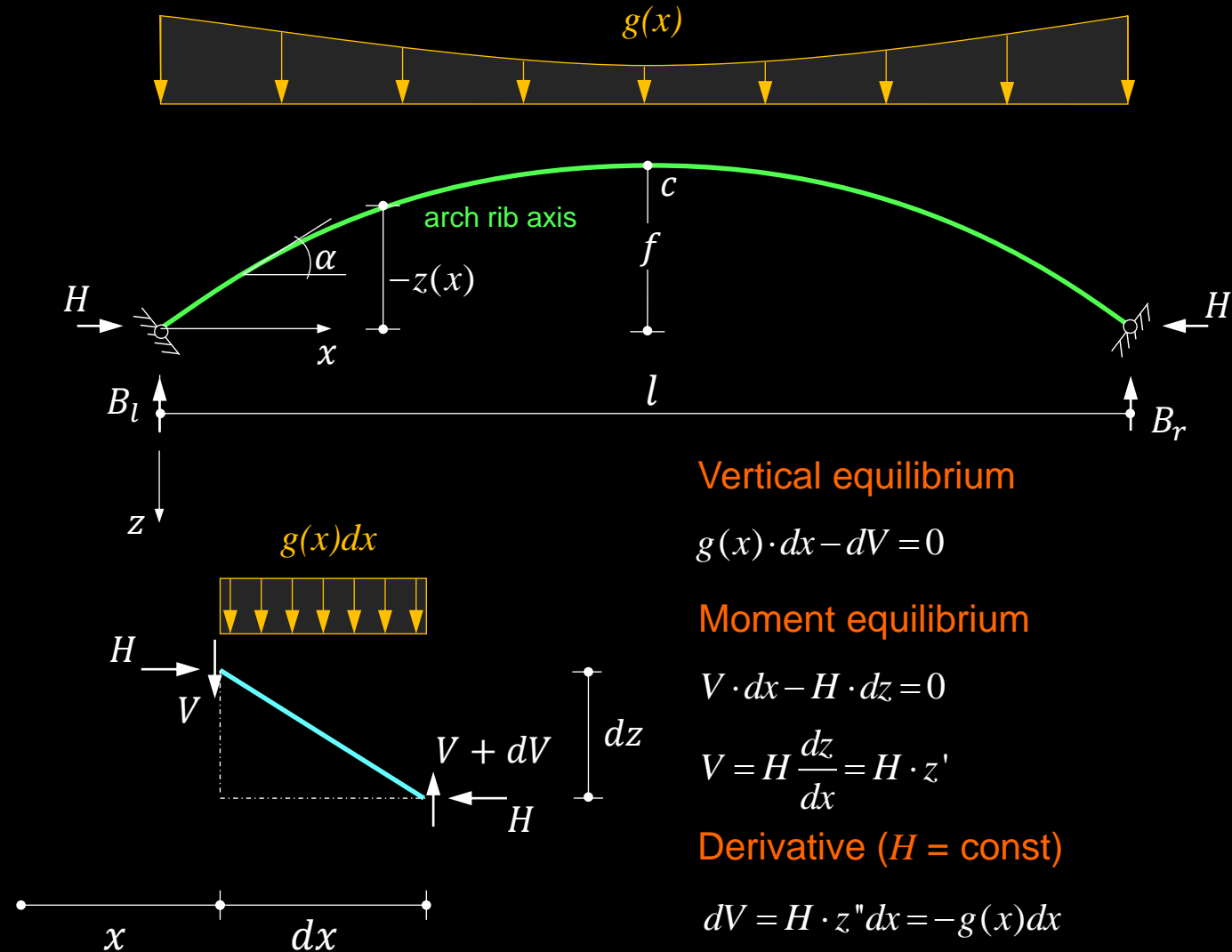

Vertical equilibrium

$$g(x) \cdot dx - dV = 0$$

Moment equilibrium

$$V \cdot dx - H \cdot dz = 0$$

$$V = H \frac{dz}{dx} = H \cdot z'$$

Derivative ($H = \text{const}$)

$$dV = H \cdot z'' dx = -g(x) dx$$

$$z'' = \frac{g(x)}{H}$$

Arch bridges – Design: Arch rib geometry

Determination of the geometry of the arch

- Generally, the differential equation has to be **integrated numerically since $g(x)$ is not constant**:
 - the self-weight of the arch is **proportional to $1/\cos\alpha$** (relevant weight: per horizontal length)
 - the arch normal force for constant thrust H is also proportional to $1/\cos\alpha$; the arch section is often increased towards the springing lines accordingly (→ **arch self weight increasing \approx with $1/\cos^2\alpha$**)
 - **point loads applied by spandrel columns** differ even if “smeared” over column spacing due to varying column height
- The “exact” anti-funicular geometry can be determined **numerically in many different ways**, even accounting for arch compression / second order effects (geometrical non-linearity).
- On the following slides, a method for determining the funicular curve by **simple hand calculations**, useful for pre-dimensioning, is presented.

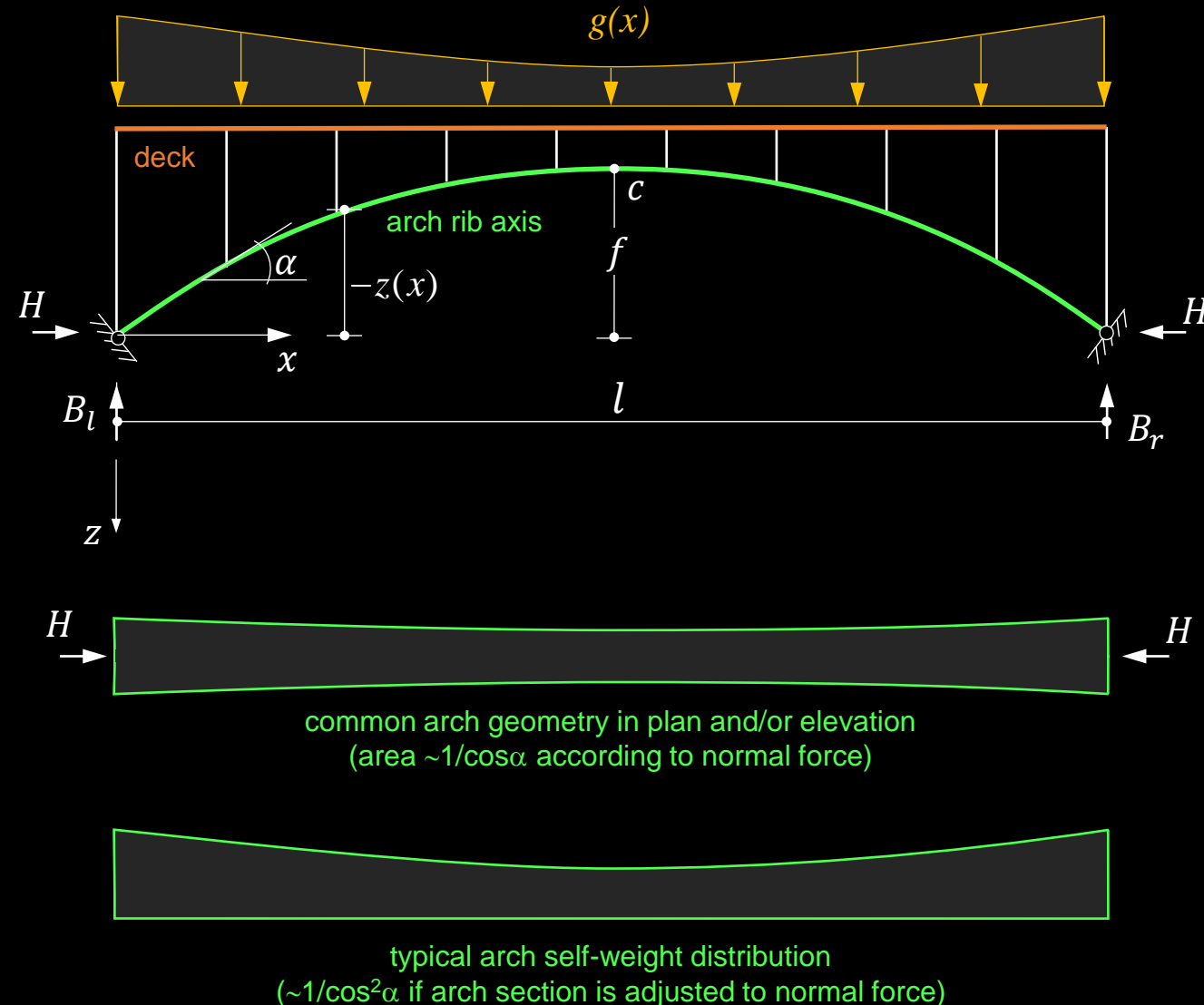

Arch bridges – Design: Arch rib geometry

Determination of the geometry of the arch

1. Determine the bending moments $M_0(x)$ in a simply supported girder (span = arch span), loaded by all permanent loads of the arch (arch rib, spandrel columns, deck girder, superimposed dead load)
2. The bending moments in the arch rib $M^A(x)$, differ from $M_0(x)$ by the moment due to the horizontal thrust H :

$$M^A(x) = M_0(x) + H \cdot z(x)$$

3. Imposing the condition $M^A = 0$ (anti-funicularity), with the bending moment at the crown $M_0^c = M_0(l/2) = H \cdot f$, the arch thrust = reaction H and the anti-funicular geometry $z(x)$ follow for a chosen value of the rise f :

$$\left. \begin{aligned} z(x) &= -\frac{M_0(x)}{H} \\ H &= \frac{M_0^c}{f} \end{aligned} \right\} z(x) = -\frac{M_0(x)}{M_0^c} f$$

(as postulated, the anti-funicular geometry is geometrically similar to the funicular polygon)

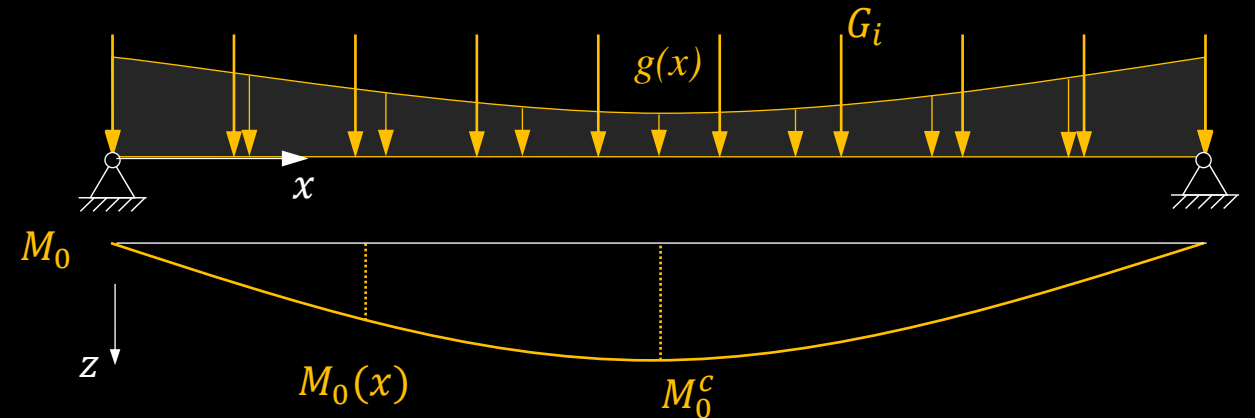
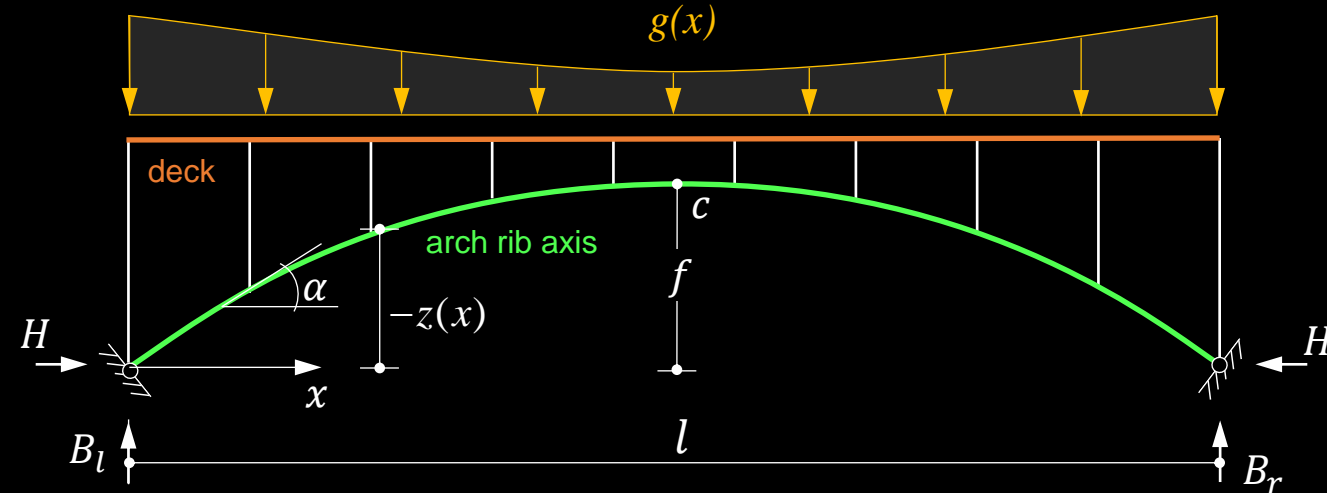

Arch bridges – Design: Arch rib geometry

Determination of the geometry of the arch

- An **iterative procedure** is required since the weights of the arch rib and spandrel columns depend on the geometry of the arch rib.
- As a **first approximation in preliminary design**, the mean permanent loads \bar{g} over the entire length of the arch can be used for further simplification.
- Hence, the arch is subjected a uniformly distributed load (corresponding to the total permanent load of the structure supported by the arch divided by its span), resulting in a quadratic parabola for the arch axis:

$$H(\bar{g}) \cong \frac{\bar{g} \cdot l^2}{8f} \quad z(x) = -\frac{8f}{\bar{g} \cdot l^2} M_0(x)$$

And the axial force in the arch is:

$$N(\bar{g}) = -\frac{H(\bar{g})}{\cos \alpha}$$

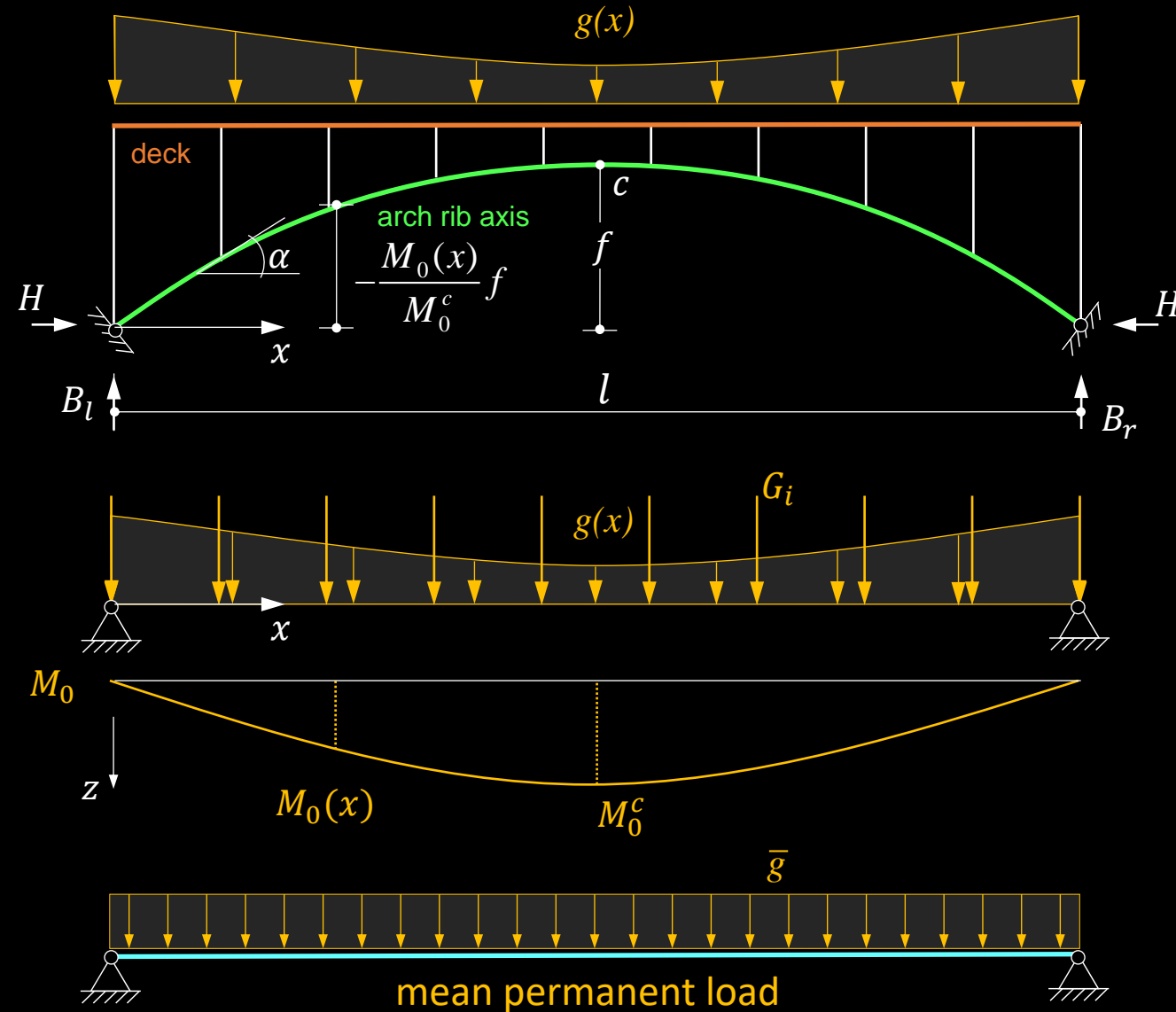

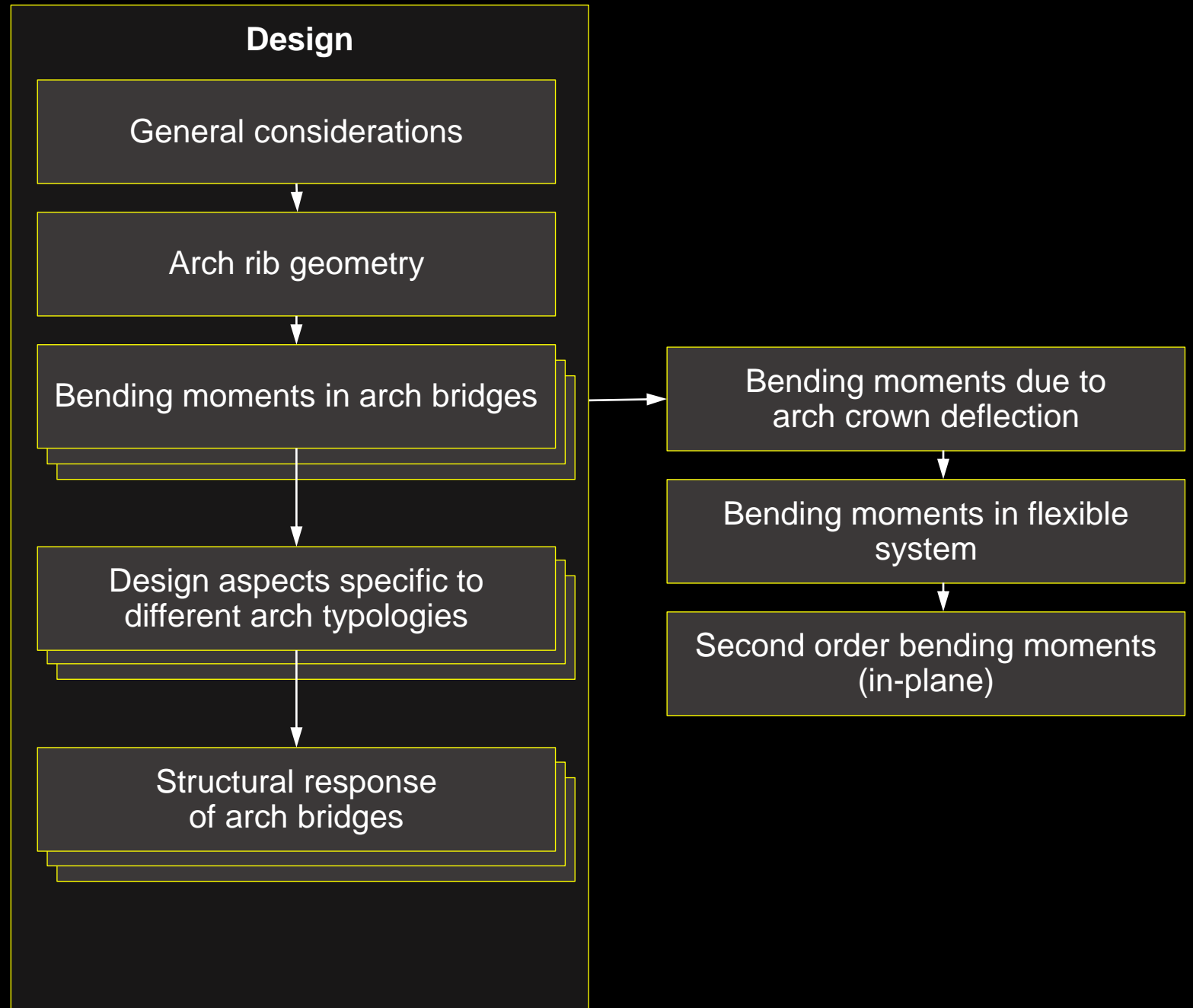

Arch bridges

Design – **Bending moments due to arch crown deflection**

(“Biegemomente infolge Scheiteleinsenkung”)

Arch bridges – Design: Bending moments due to arch crown deflection

Deflections due to horizontal support displacements Δl

- Arches can accommodate **horizontal support displacements Δl** with little axial restraint by adjusting their shape
 - deflection at arch crown δ^c
 - stress-free arch crown deflection in **three-hinged arches** (see figures):
 - causing bending moments in **two-hinged and fixed arches**, similar arch crown deflection:

$$\delta^c = \Delta l \frac{l}{4f}$$

$$\delta^c \approx \Delta l \frac{l}{4f}$$

Three-hinged arch with horizontal support displacement Δl

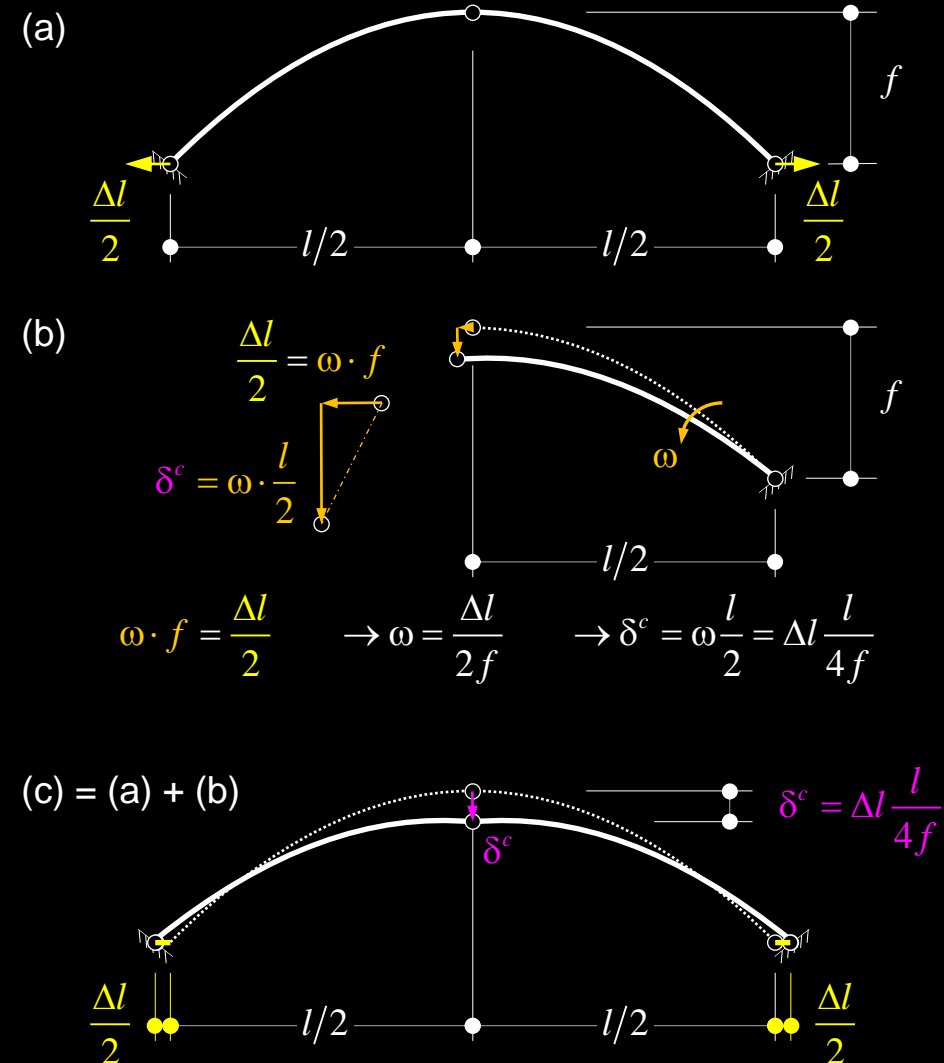

Arch bridges – Design: Bending moments due to arch crown deflection

Deflections due to imposed deformations ε

- A contraction (and, with opposite sign, expansion) of the arch rib due to imposed deformations ε (temperature change, shrinkage, ...) has a similar effect as horizontal support displacements
- With $\Delta l = \varepsilon \cdot l$, the deflection of the crown is approximately equal to: (exact for three-hinged arch)

$$\delta^c \approx \varepsilon \cdot l \frac{l}{4f}$$

Three-hinged arch with imposed strain ($\varepsilon = \alpha_T \Delta T, \varepsilon_{cs}, \dots \square 1$)

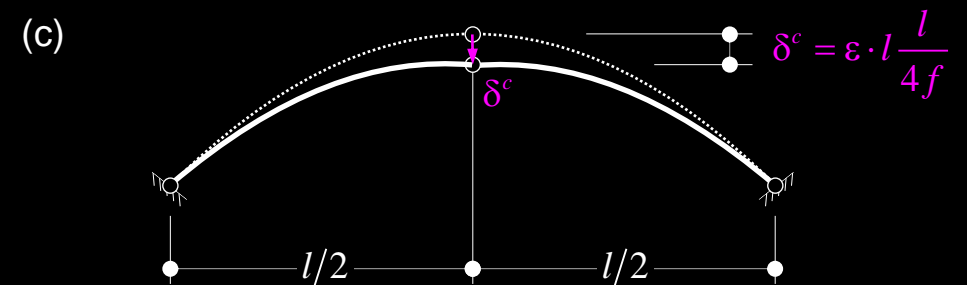
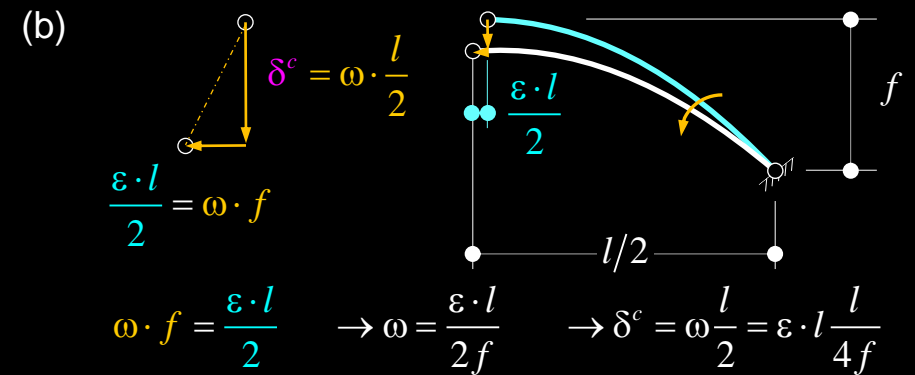
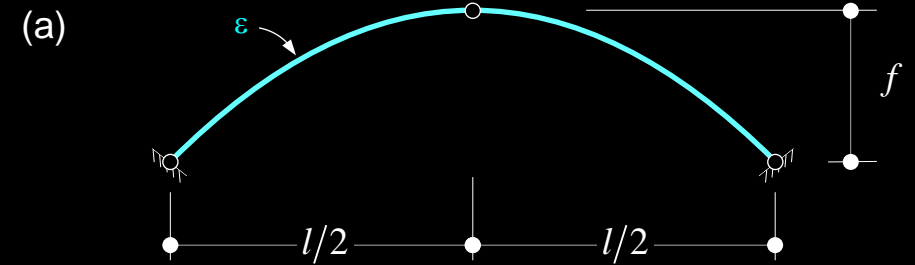

Arch bridges – Design: Bending moments due to arch crown deflection

Deflections due to arch compression N/EA

- The **arch rib** is axially very stiff, but **not perfectly rigid**
 - arch rib is compressed by arch normal force N
 - **deflections under permanent load** even if a perfectly anti-funicular geometry has been chosen
- In preliminary design, the **vertical deflection of the arch crown** due to permanent loads g can be estimated based on the arch compression at the crown $\frac{H(\bar{g})}{EA^{A,c}}$ (with $A^{A,c}$ = cross-sectional area of arch at the crown) as

$$\delta^c \cong \frac{H(\bar{g})}{EA^{A,c}} \frac{1+3(f/l)^2}{4f/l} l \quad (\text{for } EA^A = EA^{A,c} = \text{const.})$$

if the arch rib has a constant cross-section A (i.e., normal arch compression \approx proportional to $N=H/(\cos\alpha)$, and as

$$\delta^c \cong \frac{H(\bar{g})}{EA^{A,c}} \frac{l}{4f} l \quad (\text{for } EA^A = \frac{EA^{A,c}}{\cos\alpha} \rightarrow \frac{H(\bar{g})}{EA^A} \approx \text{const.})$$

if the arch rib cross-section A is proportional to $1/(\cos\alpha)$ (i.e., constant arch compression as in case of imposed ε).

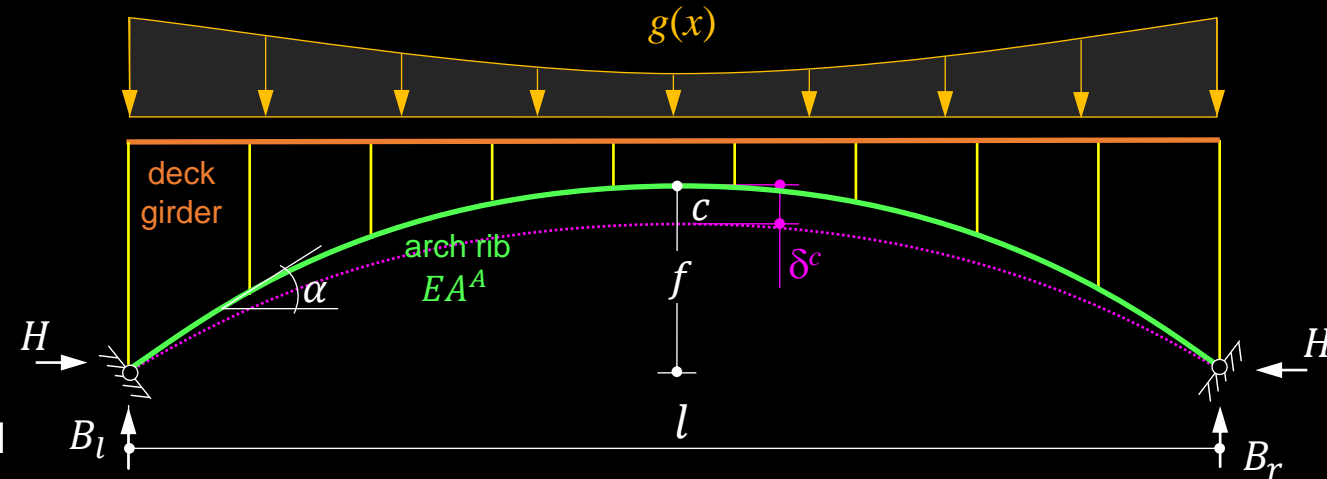

NB. The deflections due to arch compression (caused by dead load, imposed deformations or displacements) are **much higher in flat arches** (low ratios f/l):

$\frac{f}{l}$	$\frac{l}{4f}$	$1 + 3\left(\frac{f}{l}\right)^2$	$\frac{1+3(f/l)^2}{4f/l}$
1/2	0.5	1.750	0.875
1/4	1.0	1.188	1.188
1/6	1.5	1.083	1.625
1/8	2.0	1.047	2.094
1/10	2.5	1.030	2.575
1/12	3.0	1.021	3.063
1/14	3.5	1.025	3.554
1/16	4.0	1.012	4.047

(example: for $f/l = 1/8$, the crown deflects twice as much as the arch rib contracts)

(see also diagram on slide 120, case study)

Arch bridges – Design: Bending moments due to arch crown deflection

Bending moments due to arch compression

- The arch rib is much stiffer axially than arch rib and deck girder in bending
 - deflections of arch rib (due to N/EA , ε and/or Δh) are imposed to arch rib and deck girder
 - bending moments in arch rib and deck girder proportional to their stiffness and crown deflection δ^c
 - In clamped arches (with continuous deck), the bending moments can be estimated from δ^c as follows (analogous $M \leftrightarrow \delta^c = \delta_{\text{midspan}}$ in a continuous girder):

$$\left. \begin{aligned} \delta^c &= \frac{\bar{g}l^4}{384EI} \\ M^c &= -\frac{1}{2}M^s = \frac{\bar{g}l^2}{24} \end{aligned} \right\} \rightarrow \begin{cases} M^{D,c} = -\frac{M^{D,s}}{2} \cong \frac{16EI^D}{l^2} \delta^c & \text{deck girder} \\ M^{A,c} = -\frac{M^{A,s}}{2} \cong \frac{16EI^A}{l^2} \delta^c & \text{arch rib} \end{cases}$$

$$\left(\frac{M^c}{\delta^c} = \frac{\bar{g}l^2}{24} \cdot \frac{384EI}{\bar{g}l^4} = \frac{16EI}{l^2} \text{ is independent of } \bar{g} \right)$$

where M^D = moment in deck girder, M^A = moment in arch rib, c = crown, s = springing line (arch abutment)

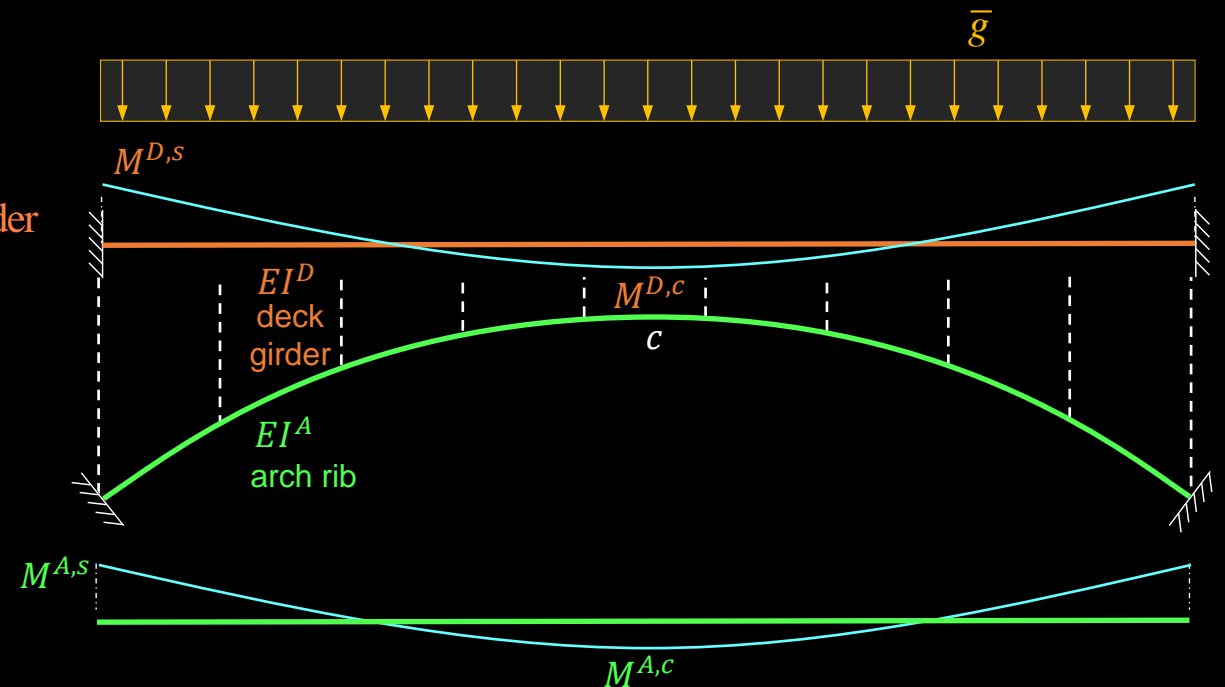
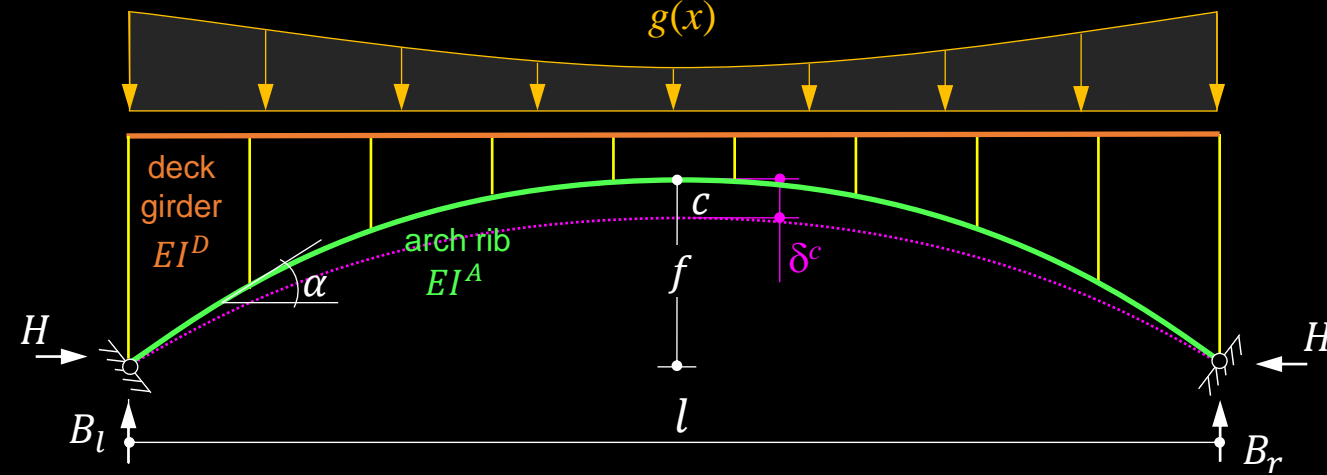

Arch bridges – Design: **Bending moments due to arch crown deflection**

Bending moments due to arch compression

- Bending moments due to arch compression generally occur in **arches built on conventional centring**.
- In concrete arches, the **crown deflection increases with time due to creep**, but the **bending moments remain constant** (one casting system, see Advanced Structural Concrete)
- If the arch is **lifted off the formwork by opening it in the crown (with hydraulic jacks, see figure)**, or the arch is built by stay cantilevering, the arch rib is already compressed at closure
→ **no crown deflection at $t = 0$** (time of closure), but
→ in concrete arches, **crown deflections and corresponding bending moments build up** over time due to **creep**
→ bending moments of up to **80% of the values of the arch built on centring** (= one casting system, see Advanced Structural Concrete) can result at $t = \infty$
- The benefit of opening concrete arches in the crown can be increased if the **jacks are kept installed**, adjusting the jacking force over a **long period of time** (as done e.g. in the Krk Bridges during 5 years, see section *Erection*).



Arch bridges

Design – **Bending moments in flexible system**

Arch bridges – Design: Bending moments in flexible system

General behaviour – Load sharing

- Under loads causing bending moments in the arch (\neq proportional to loads used for determining the anti-funicular geometry, see Slide 22 for decomposition of load), the system acts like a flexible frame
 - deflections of arch rib and deck girder equal (deck arch, stiff columns) or very similar (tied arch, flexible hangers)
 - bending moments shared among deck girder and arch rib in proportion to their stiffness
- Generally, the bending stiffness of deck girder and arch rib is of similar magnitude, and both elements carry a portion of the total bending moments, see figure.

Note that this “load sharing” also applies to the bending moments due to arch compression, as these are proportional to the stiffnesses as well.

General load
(part of load not proportional to loads used for determining the anti-funicular geometry generates bending moments)

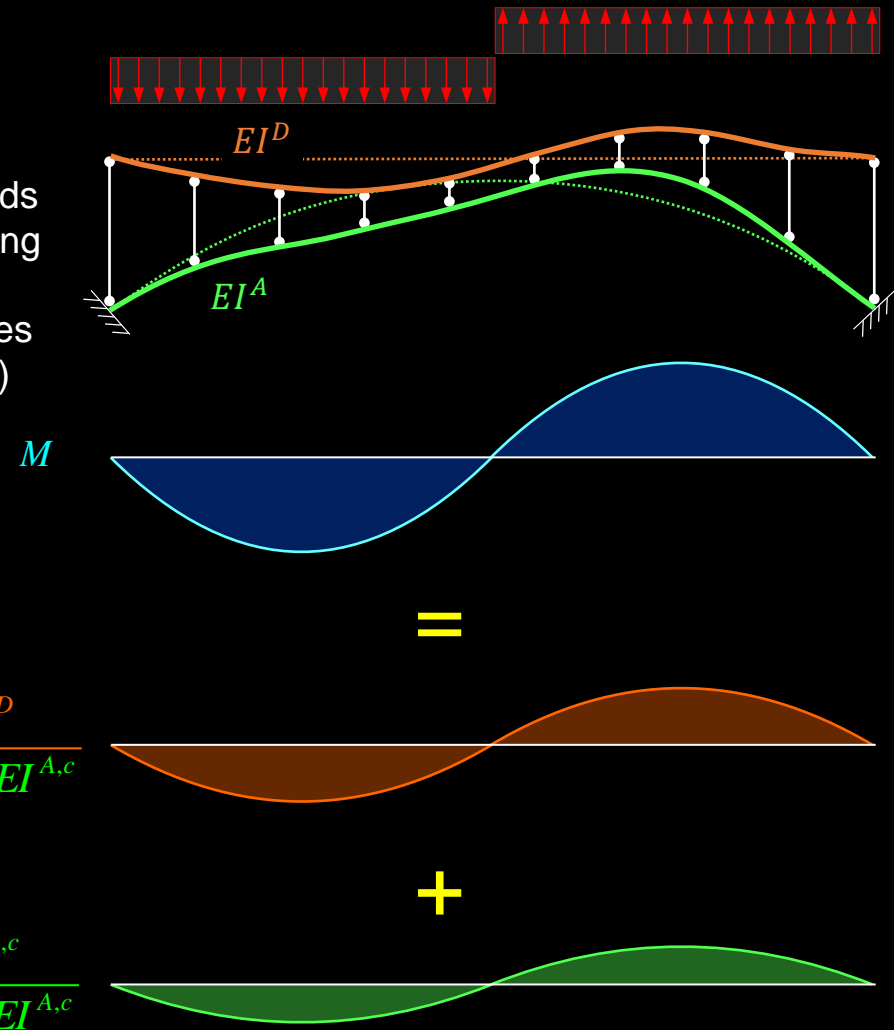

$$M^D \approx M \frac{EI^D}{EI^D + EI^{A,c}}$$

$$M^A \approx M \frac{EI^{A,c}}{EI^D + EI^{A,c}}$$

Arch bridges – Design: Bending moments in flexible system

Solution using force method – General case

- Basically, the **bending moments in the flexible system** can be determined using the **force method**
 - select isostatic **basic system** and introduce redundant variables
 - determine **flexibility coefficients**
 - formulate **compatibility** and solve for redundant variables
- However, even if the columns (hangers) are idealised as pin-jointed members, the **solution is tedious in the general case**
 - use **frame analysis software**
 - for preliminary design, **estimate bending moments** using values shown on **slide 63**

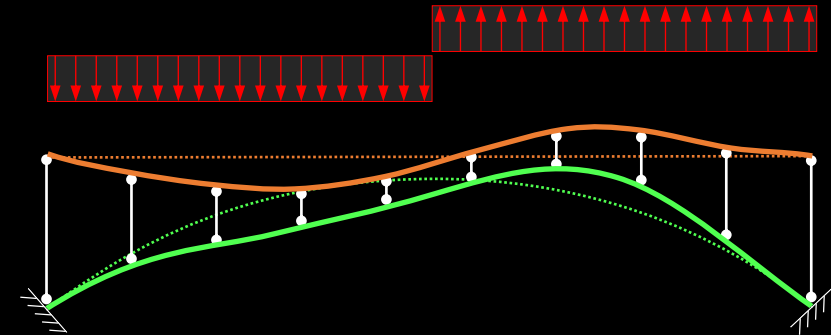

Redundant moments:

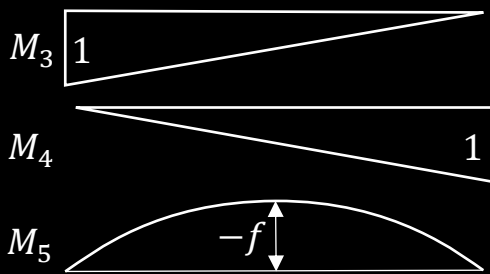

$$\delta_{ik} = \int_0^l M_i \frac{M_k}{EI^D} d\xi + \int_0^l M_i \frac{M_k}{EI^A} ds$$

δ_{ik} : flexibility coefficients
 D : deck girder
 A : arch

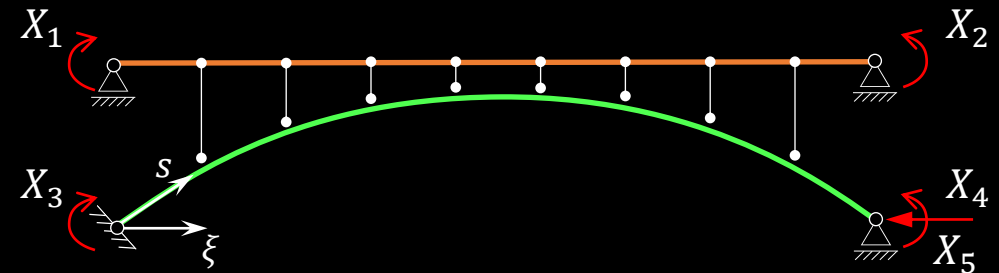

Arch bridges – Design: Bending moments in flexible system

Solution using force method – Deck-stiffened arches

- If the bending stiffness of the deck girder is much **higher** than that of the arch rib, the **latter** can be neglected
 - “**deck-stiffened arch**”
 - bending moments carried (almost) by the **deck girder alone**
 - **reduced degree of statical indeterminacy**
- If the columns (hangers) are idealised as pin-jointed members, the system is **three times statically indeterminate**
 - solution using force method possible, but obsolete
 - use **frame analysis software**
 - for preliminary design, **estimate bending moments** using values shown on **slide 63**

Redundant moments:

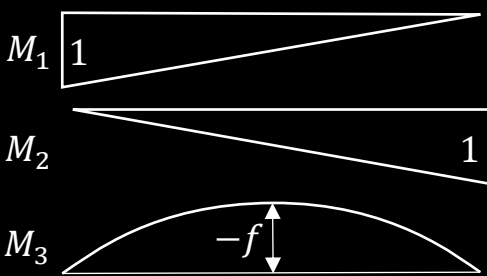

$$\delta_{ik} = \int_0^l M_i \frac{M_k}{EI^D} d\xi$$

δ_{ik} : flexibility coefficients
 D : deck
 A : arch

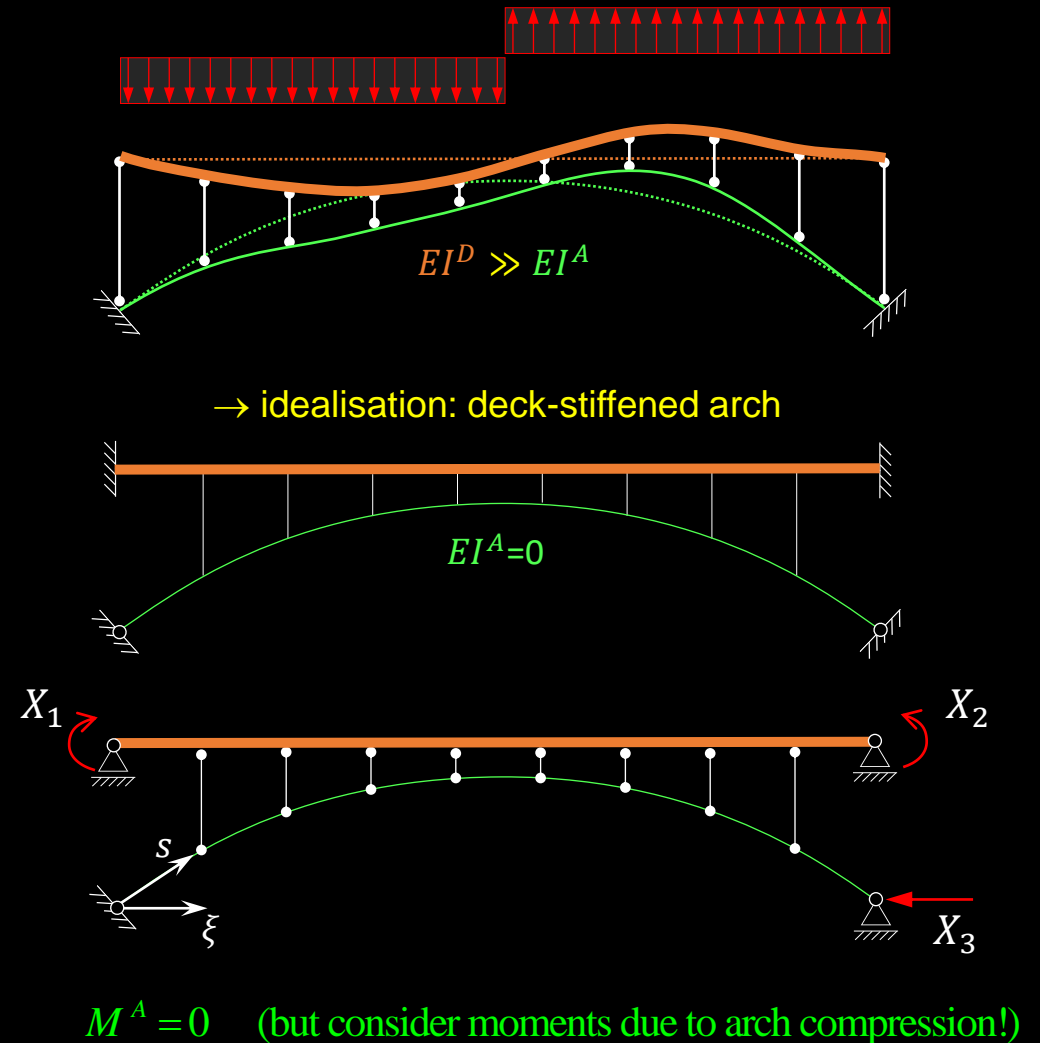

Arch bridges – Design: Bending moments in flexible system

Solution using force method – Stiff arches

- If the bending stiffness of the deck girder is much lower than that of the arch rib, the former can be neglected
 - “stiff arch”
 - bending moments carried (almost) by the arch rib alone
 - reduced degree of statical indeterminacy
- If the columns (hangers) are idealised as pin-jointed members, the system is three times statically indeterminate
 - solution using force method possible, but obsolete
 - use frame analysis software
 - for preliminary design, estimate bending moments using values shown on slide 63

Redundant moments:

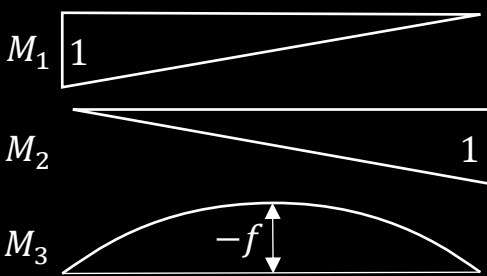

$$\delta_{ik} = \int_0^l M_i \frac{M_k}{EI^A} ds = \int_0^l M_i \frac{M_k}{EI^{A,c}} d\xi$$

(for $EI^A \cos \alpha = EI^{A,c}$)

δ_{ik} : flexibility coefficients

D : deck

A : arch

A,c : arch at crown

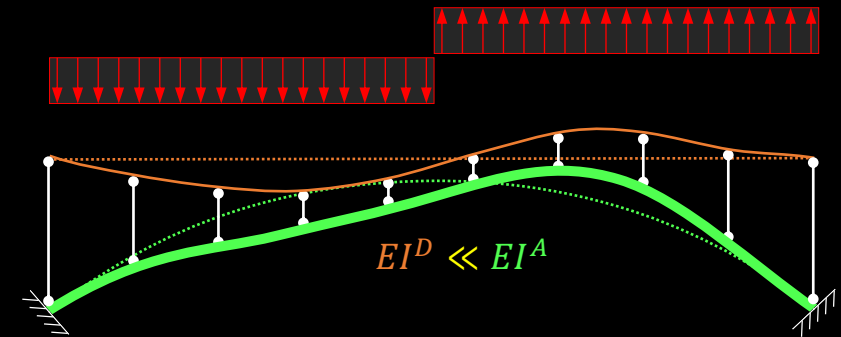

→ idealisation: stiff arch

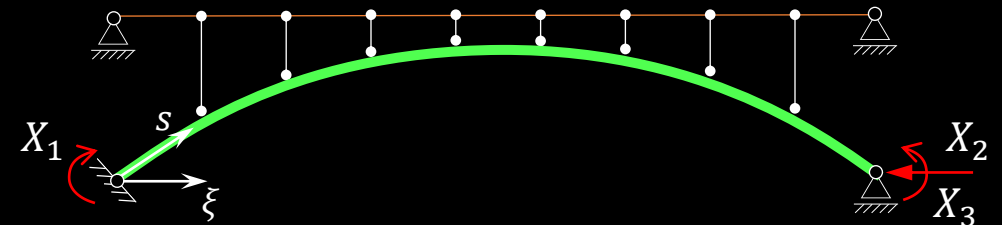
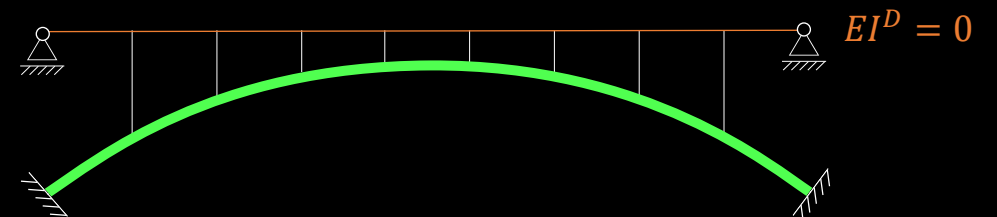

$M^D = 0$ (but consider moments due to arch compression!)

Arch bridges – Design: Bending moments in flexible system

Approximate values of bending moments due to traffic load (clamped arch with continuous deck girder)

- Generally, the maximum bending moments need to be determined considering different load positions (e.g. using influence lines)
- In preliminary design, it is sufficient to check the maximum bending moments
 - at the springing lines (arch abutments)
 - at the quarter-points
 - at the crown
- These may be estimated using the two load cases illustrated in the figure:
 - symmetrical load over middle third of span
 - asymmetrical load on one half span
 and distributed among arch rib and deck girder according to their stiffnesses

$$M^D \approx M \frac{EI^D}{EI^D + EI^{A,c}} \quad M^A \approx M \frac{EI^{A,c}}{EI^D + EI^{A,c}}$$

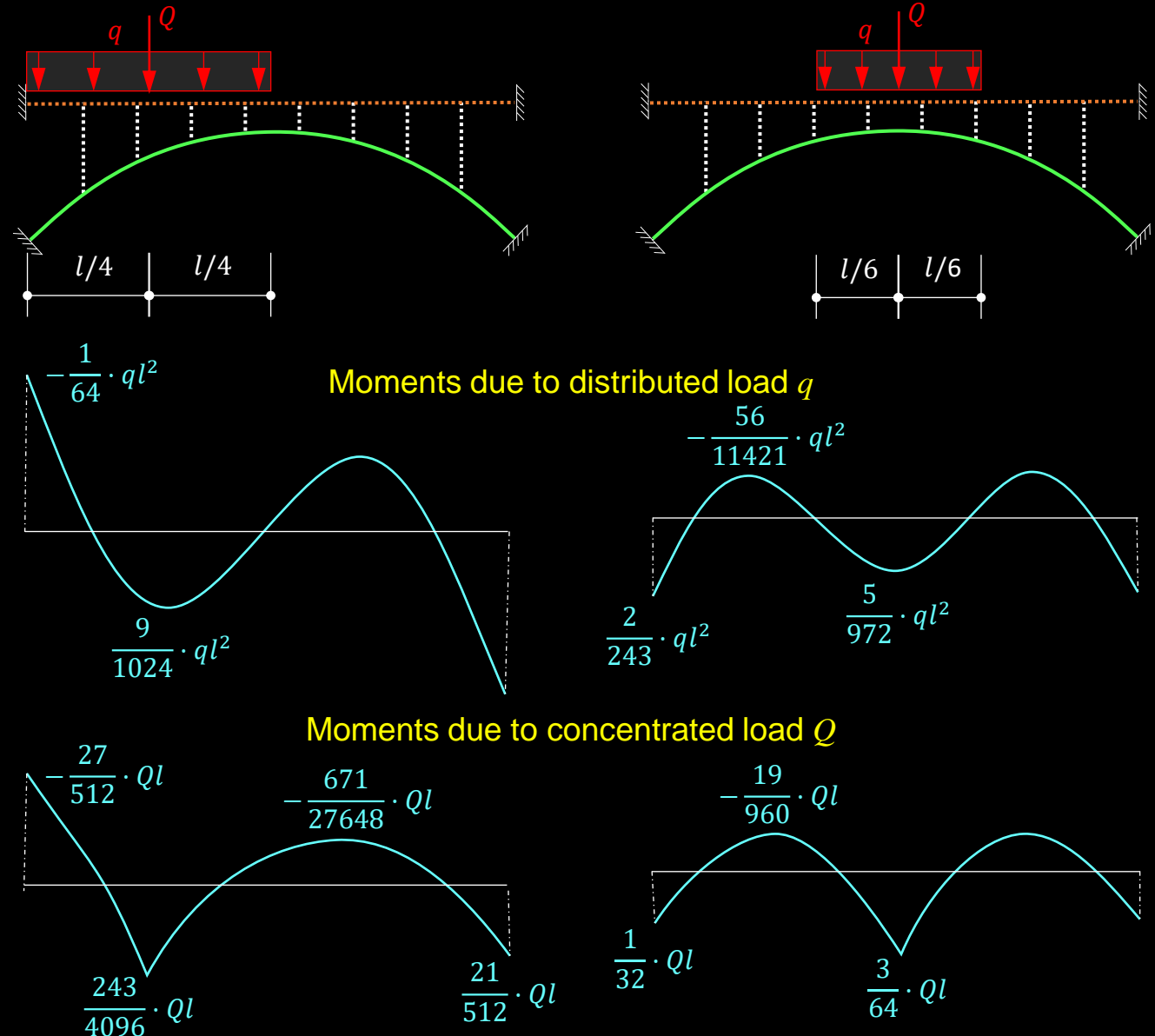

Arch bridges

Design – **Second-order bending moments**

Arch bridges – Design: Second order bending moments

- Arches are **compression members**
 - in addition to the (first order) moments in the flexible system, see previous slides, **second order bending moments must be considered** unless the arch is very stiff and they are negligible
 - for **deck arches**, second order analysis can usually be limited to in-plane bending moments (deck girder provides lateral stability)
 - for **tied arches**, **out-of-plane stability** (transverse buckling of the arch resp. corresponding 2nd order bending moments) are typically more critical
- In detailed design, a second-order analysis is carried out, assuming suitable imperfections (see substructure chapter) and the governing load positions, which typically are:
 - **in-plane** stability: traffic load in one **half-span**
 - **out-of-plane** stability: traffic load in **full span**
- In the preliminary design of deck arches, it is sufficient to consider **anti-symmetrical in-plane buckling** see figures and next slide.

In-plane buckling of (deck) arch

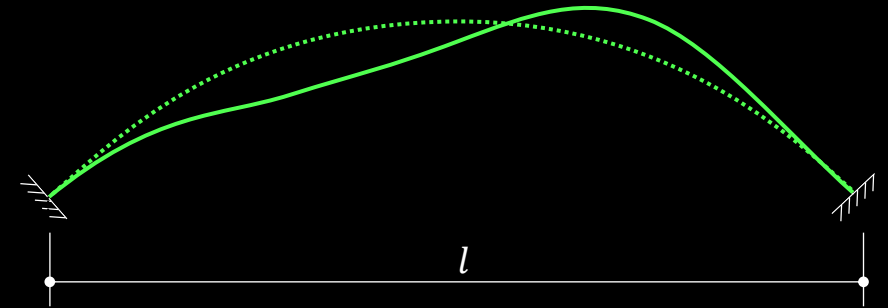

Approximate in-plane buckling length and deflected shape (clamped-hinged)

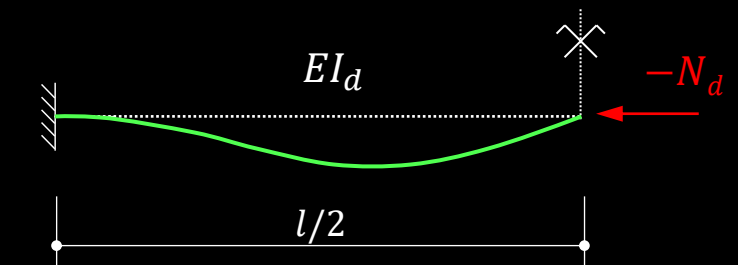

Maximum eccentricity

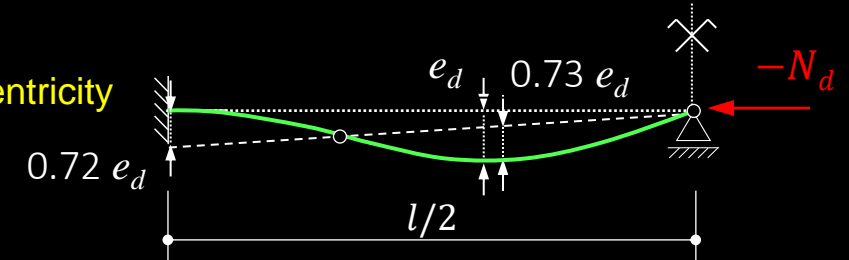

Arch bridges – Design: Second order bending moments (in-plane)

- In the preliminary design of concrete deck arches, 2nd order in-plane bending moments can be determined using the curvature based method of SIA 262, see substructure chapter, considering arch rib and deck girder together as a compression member.
- If the deck is prestressed and the arch stiffness increases towards the abutments in line with the arch normal force, i.e.

$$EI^A(x) \approx \frac{EI^{A,c}}{\cos \alpha(x)}$$

a constant bending stiffness may be assumed:

$$EI_d \cong \frac{1}{4} (EI^{A,c} + EI^D) \rightarrow \chi_d = 4 \frac{M_{Rd}^{A,c} + M_{Rd}^{D,c}}{EI^{A,c} + EI^D}$$

- The first-order eccentricities correspond to the bending moments for traffic load on one half span (previous slides), and the total eccentricity is as usual: $e_d = e_{0d} + e_{1d} + e_{2d}$
- The c-factors (superposition of actions) are given in the figure, and the resulting bending moments are resisted by arch rib and deck girder jointly, i.e.

$$M^D \approx -N_d e_d \cdot \frac{EI^D}{EI^D + EI^{A,c}} \quad M^A \approx -N_d e_d \cdot \frac{EI^{A,c}}{EI^D + EI^{A,c}}$$

Approximate verification of in-plane 2nd order moments in deck arch

$$e_d = e_{0d} + e_{1d} + e_{2d} \quad \left\{ \begin{array}{l} e_{0d} = \alpha_i \cdot \frac{l_{cr}}{2} \\ e_{1d} = \frac{M_{1d}}{-N_d} \\ e_{2d} = \chi_d \frac{l_{cr}^2}{c} \end{array} \right.$$

eccentricity due to geometric imperfection
first order eccentricity of action
eccentricity due to member deformation

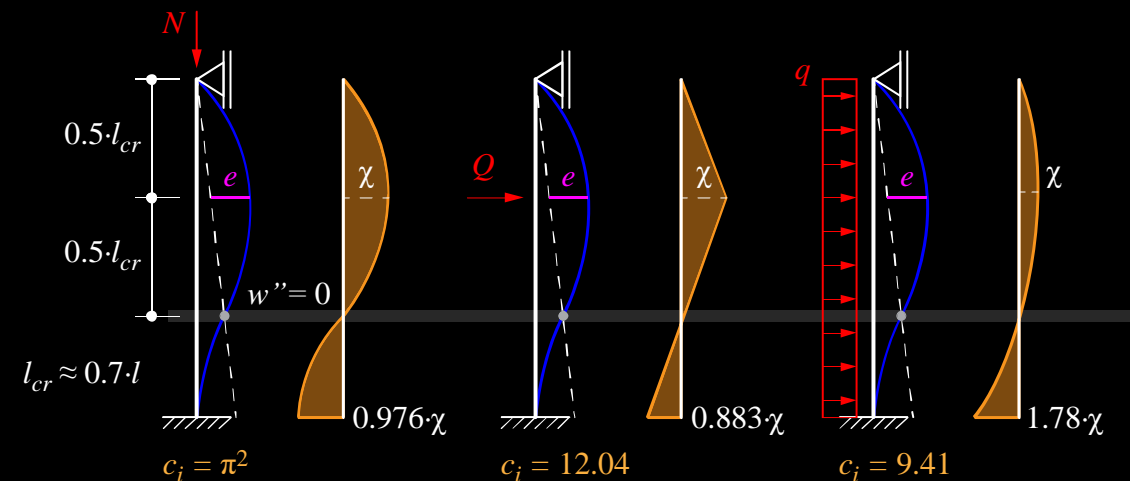

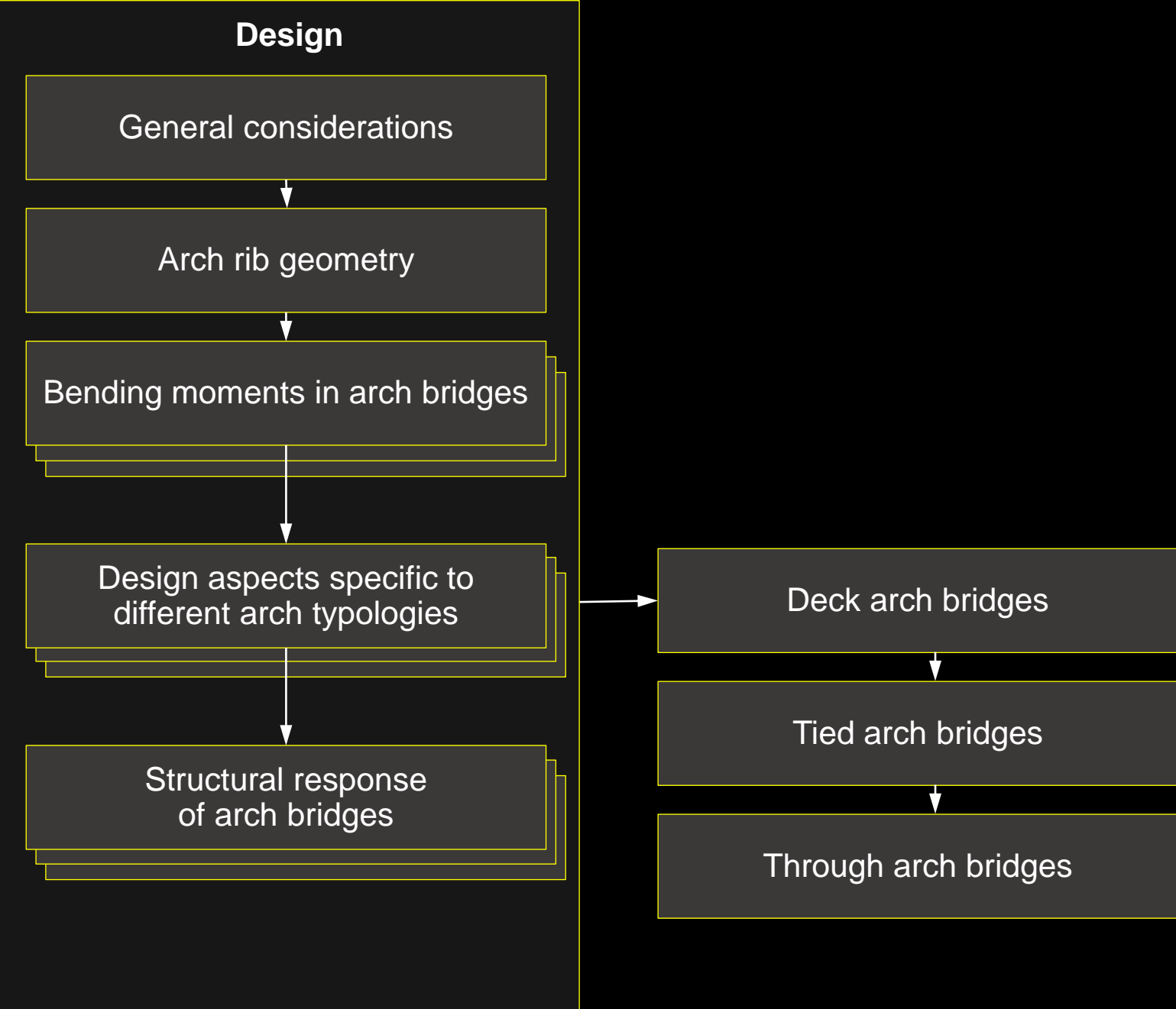

Arch bridges

Design – Deck arch bridges

Arch bridge – Design: Deck arch bridges

Deck girder – General

- The deck girder is supported by the arch through the axially stiff spandrel columns
 - deck girder and arch share the **same deflections**
 - the cross-sections of girder and arch must be chosen in consideration of their interaction:
 - ... **stiff arch ↔ slender deck girder**
 - ... **slender arch ↔ stiff deck girder**
 - the **stiffness ratio of deck and arch EI^D/EI^A** is highly relevant for the structural response
- The **girder depth** is usually kept **constant** over the entire length of the bridge, and the girder needs to resist **additional bending moments due to frame action** (crown deflects due to arch compression, see structural response)
 - less slender than in girder bridges
 - for prestressed concrete $1/15 \leq h/l \leq 1/12$



Arch bridge – Design: Deck arch bridges

Deck girder – Cross-section

- For reasonably stiff arches ($EI^D \ll EI^A$), double-T or solid slab deck girders can be used, regardless of the arch span
 - bending moments in flexible system primarily resisted by arch rib
 - bending moments in the deck girder depend mainly on the spandrel column span
 - behaviour of deck girder similar to continuous girder bridges (hogging moments $\approx 2 \cdot$ sagging)

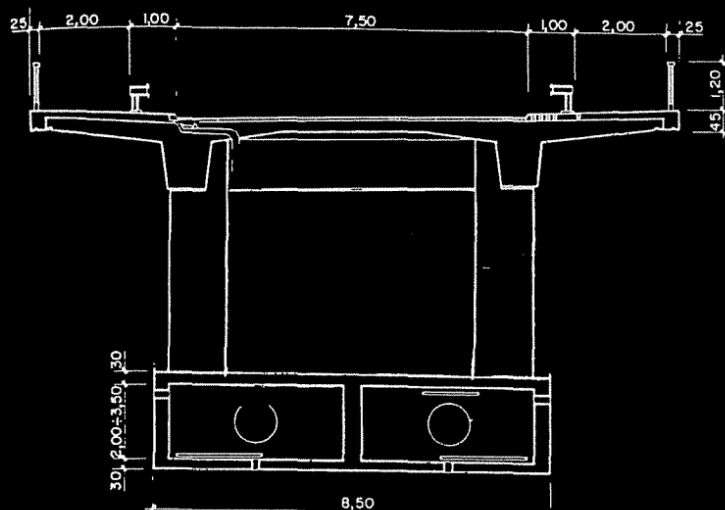

$l = 143 \text{ m}$

$f/l = 1 / 4.8$

Argentobel Bridge, Germany, 1986. BUNG Ingenieure AG

Arch bridge – Design: Deck arch bridges

Deck girder – Cross-section

- For stiff arches ($EI^D \ll EI^A$), slender steel-concrete composite decks are also possible, regardless of the arch span.



$l = 255 \text{ m}$

$f/l = 1 / 5.5$

Arco de los Tilos, S. Pérez Fadón / J.E. Herrero Beneitez, Isla de La Palma, Canarias, 2004.

Arch bridge – Design: Deck arch bridges

Deck girder – Cross-section

- In flexible arches ($EI^D \approx EI^A$ or even $EI^D > EI^A$), the stiffness of the deck girder has a significant influence on the behaviour of the frame system
 - significant part of **frame moments resisted by deck girder**
 - **higher deck girder stiffness** required
 - **box girder cross-sections** for deck of long-span arches
 - sagging and hogging moments in the girder of similar magnitude over the entire length of the arch



Arch bridge – Design: Deck arch bridges

NB. Aesthetics (arch abutments in river)?



Veitshöchheim viaduct, Germany, 1986. ILF Beratende Ingenieure & Leonhardt, Andrä und Partner

Arch bridge – Design: Deck arch bridges

NB. Aesthetics (arch abutments on shore)!



$l = 324 \text{ m}$

$f/l = 1 / 4.5$

Viaducto del Embalse de Alcántara (Río Tajo), Extremadura, Spain, 2016. CFCSL.

Arch bridge – Design: Deck arch bridges

Deck girder – Prestressing

- Concrete deck girders are commonly **fully prestressed for permanent loads**
 - higher, uncracked stiffness improves **global stability of the frame system** (cracked-elastic second-order analysis is subjected to many uncertainties)
 - enhanced durability

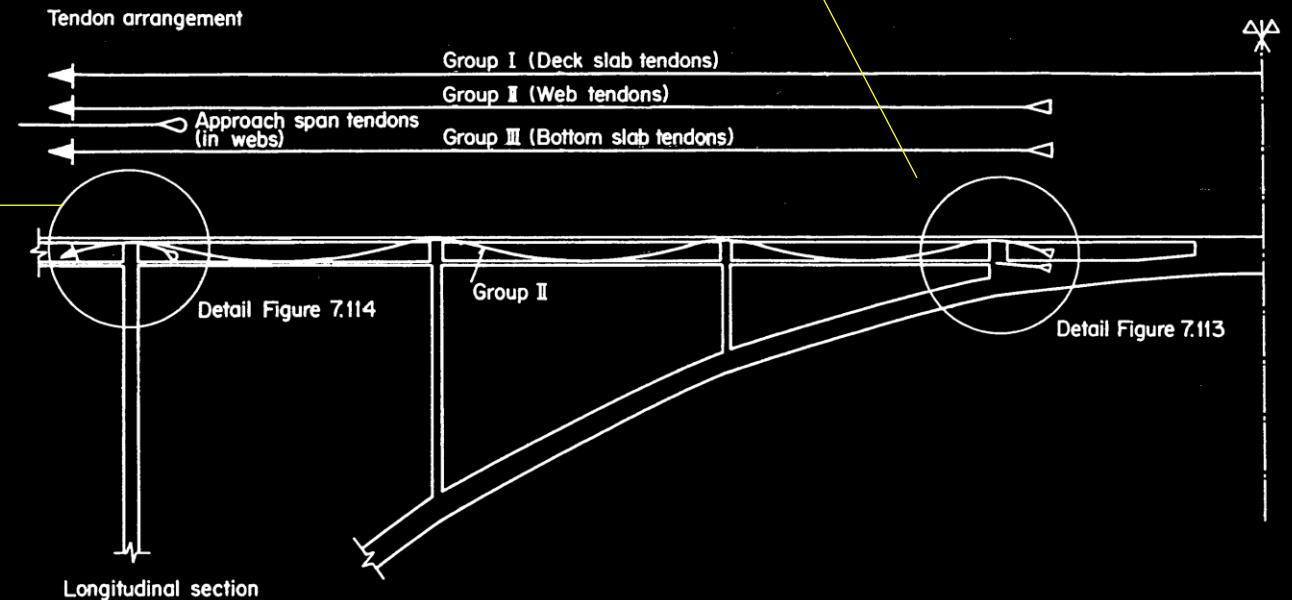
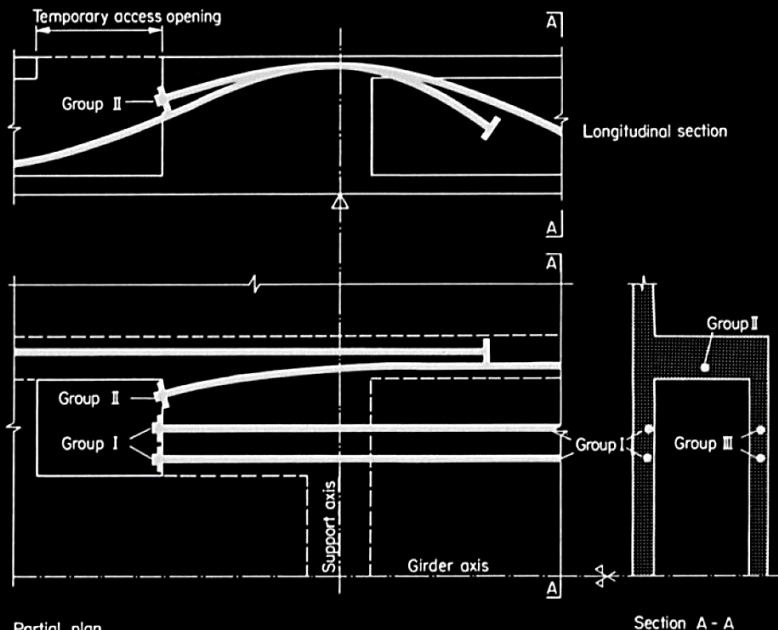
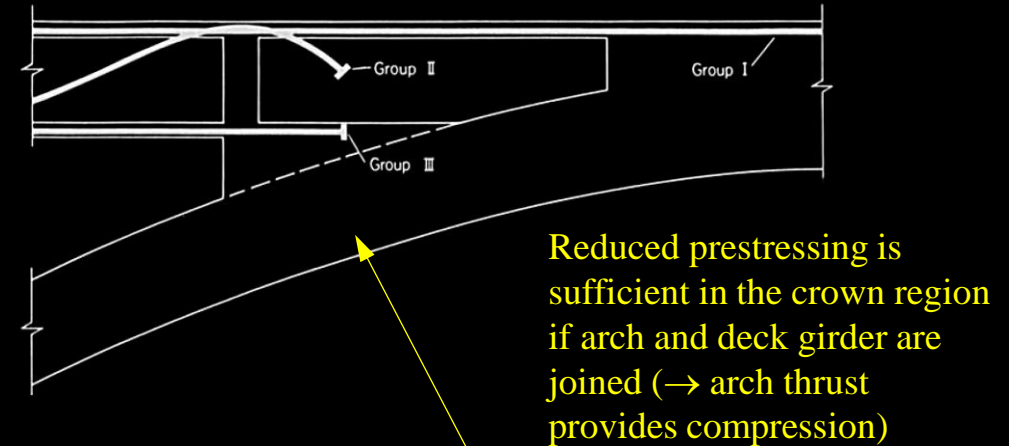

Arch bridge – Design: Deck arch bridges

Arch rib

The arch transmits a significant horizontal reaction to the supports → a strong soil is ideal

The structural response of the arch depends strongly of the ratio of rise-span f/l



The structural response of the arch depends strongly on the **supports and hinge** arrangement:

- clamped arch
- two-hinged arch
- three-hinged arch



Arch bridge – Design: Deck arch bridges

Arch rib

- Clamped arch:

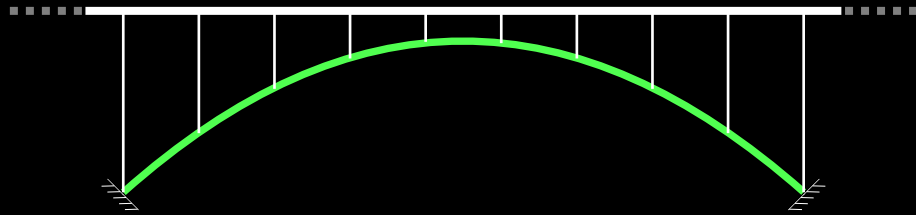

- robust (specially during construction)
- superior for non-symmetric actions
- low clamped arches $f/l < 1/10$ are sensitive to imposed deformations and movements of the foundation (see structural response)
- high arches are more economical (but low arches often aesthetically more satisfactory).



$l = 255 \text{ m}$

$f/l = 1/5.5$

Tilos Bridge, Spain, 2004. S. Pérez-Fadón Martínez and J.E. Herrero Benítez

Arch bridge – Design: Deck arch bridges

Arch rib

Usual **cross sections** of large-span arch ribs are:

- Hollow sections (single- or multi-cell)
 - ... low weight
 - ... high stiffness (radius of gyration I/A)
- Trusses (in steel bridges)

For shorter spans $l < 150$ m, solid cross sections or U-shaped cross sections are suitable

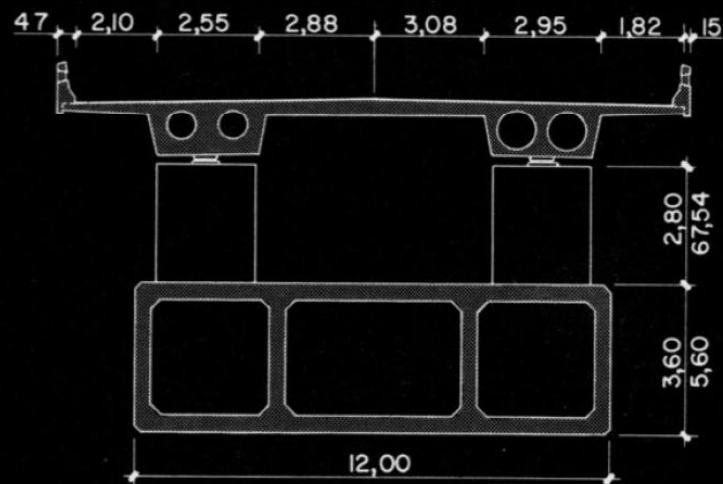

Arch bridge – Design: Deck arch bridges

Arch rib

Usual **cross sections** of large-span arch ribs are:

- Hollow sections (single- or multi-cell)
 - ... low weight
 - ... high stiffness (radius of gyration I/A)
- Trusses (in steel bridges)

For shorter spans $l < 150$ m, solid cross sections or U-shaped cross sections are suitable

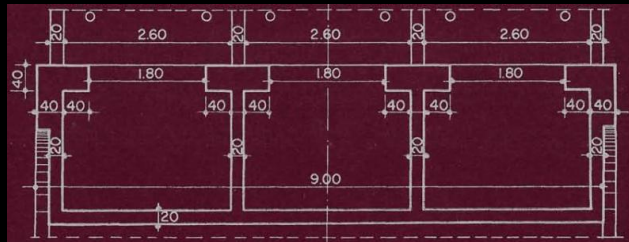
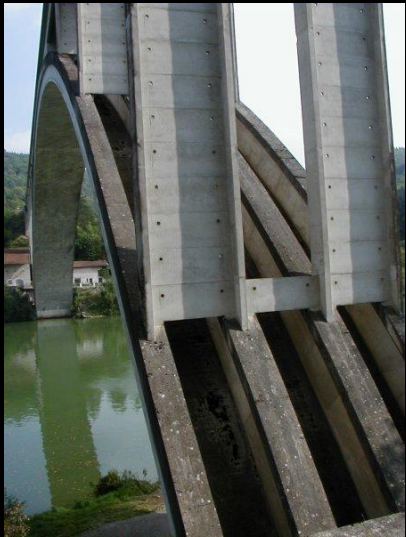

$$f = 30 \text{ m}$$

$$l = 125 \text{ m}$$

$$f/l = 1 / 4.17$$

Serrieres-sur-ain bridge, France, 1959. Jean Courbon

Arch bridge – Design: Deck arch bridges

Spandrel columns

- Spandrel columns should be monolithically connected to deck girder and arch where possible, e.g. using slender columns
 - enhanced durability
 - simpler construction
 - higher stiffness (frame) under non-anti-funicular load
- If hinged connections are required, concrete hinges are preferred (durability, maintenance) to bearings

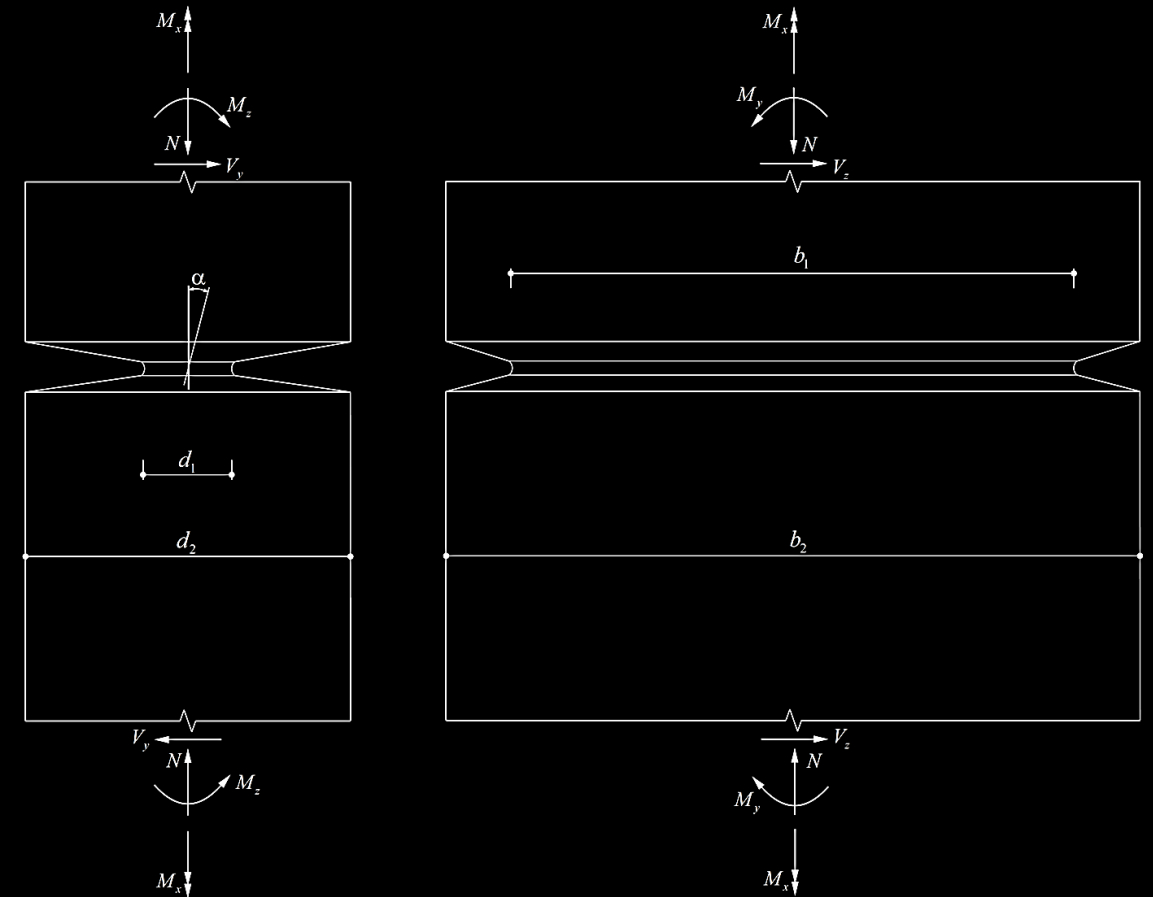
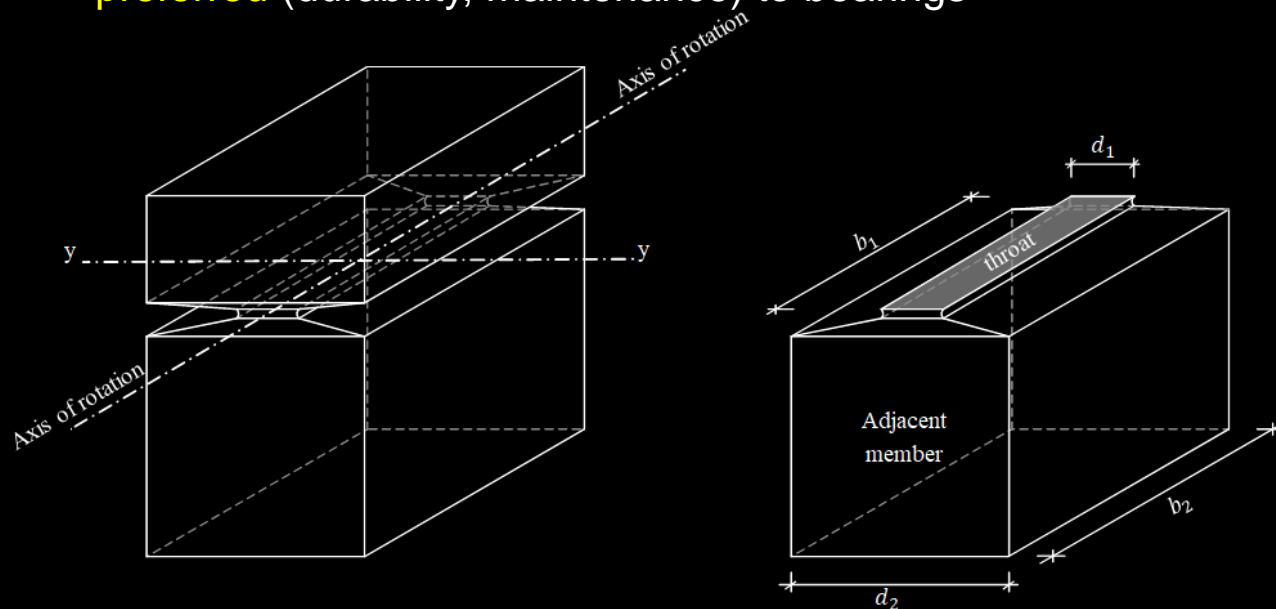

Arch bridge – Design: Deck arch bridges

Spandrel columns

- Spandrel columns should be monolithically connected to deck girder and arch where possible, e.g. using slender columns
 - enhanced durability
 - simpler construction
 - higher stiffness (frame) under non-anti-funicular load
- If hinged connections are required, concrete hinges are preferred (durability, maintenance) to bearings





Arch bridge – Design: Deck arch bridges

Stiffness of deck girder vs arch rib

- Basically, the **required bending stiffness** (stability, flexible system moments) can be arbitrarily allocated to the arch rib or the deck girder
- **Concrete arch ribs have a high moment capacity** without extra cost due to the compressive normal force, and a **high stiffness EI^A of the arch rib** is also favourable during construction
 - for **structural efficiency**, the concrete **arch rib should be stiffer** in bending **than the deck** (such that it will carry most of the moments)
- On the other hand, the deck girder always provides a minimum stiffness
 - **very slender arches possible** if built on centring
 - “**secret**” of the **elegance** of arch bridges designed by **Christian Menn**
 - however, arches built on centring are **uneconomical** (even if still built occasionally, if economy is of little importance)

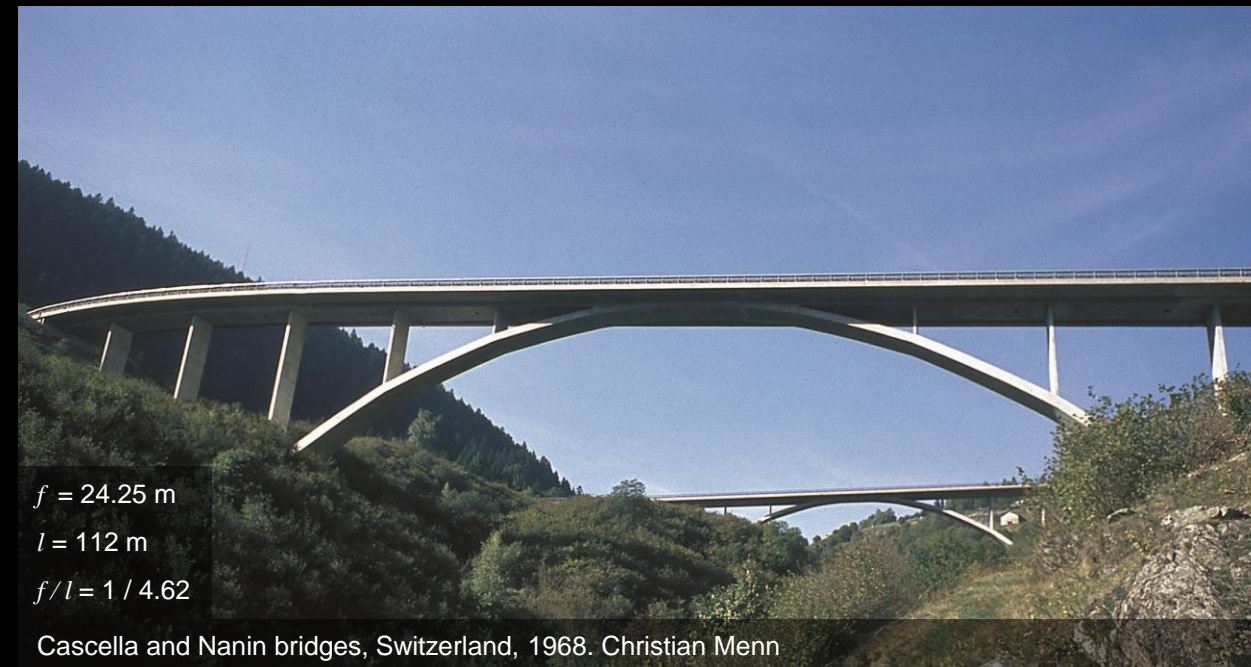
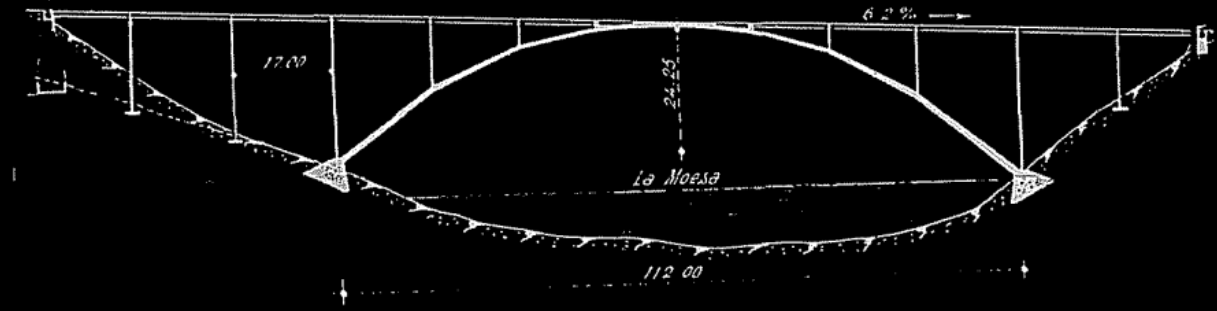

Arch bridge – Design: Deck arch bridges

Aesthetics

When designing a deck arch bridge, the following points – mostly proposed by Ch. Menn – should be considered; note that these are no rules, but merely **points of orientation**:

- The connecting line of the **arch abutments** (springing line) resp. the arch intersection with the ground should be **parallel to the girder** (top figure).
- Providing **at least 4-6 spandrel columns** at equal distance (5-7 equal parts) is preferable (if less spandrel columns are required, check feasibility of strut-frame bridge, see frame bridges, and if not possible, provide polygonal arch).
- If arch and deck (stiffening girder) are **separated**, **no column should be provided at midspan**.
- If **arch and deck (stiffening girder) are joined monolithically**, a satisfactory appearance is obtained by using the same depth for girder and arch and making sure that the arch axis is tangent to the (extended) girder soffit line (intrados), see bottom figure).

Deck arch elevation
[Menn 1990]

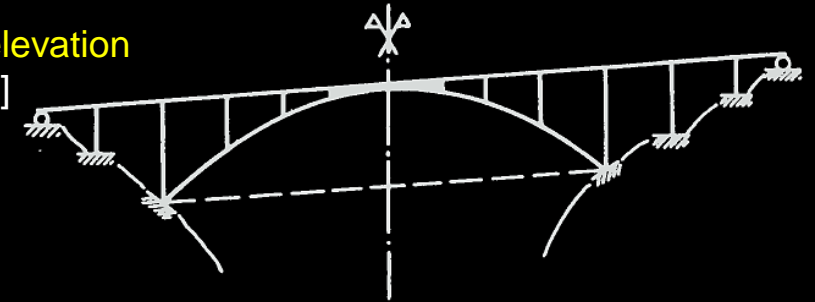

Joined crown
[Menn 1990]



Separated crown
[Menn 1990]

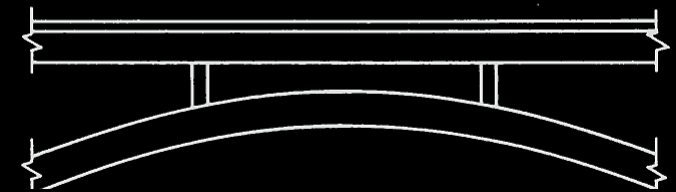

Proposed geometry of joined crown
[Menn 1990]

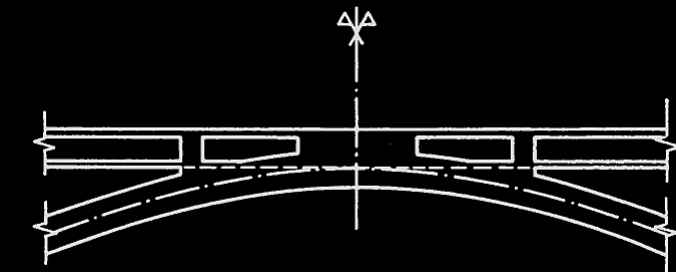

Arch bridges

Design – Tied arch bridges

Arch bridge – Design: Tied arch bridges

- As already outlined (general considerations), **tied arch bridges are suitable for**
 - locations with **soft soil**
 - **single-span bridges with low clearance**
- The **in-plane stability** of the arch rib is ensured by the **deck girder acting in tension**.
- Other than in deck arches, the arch rib is not commonly stabilised by the deck girder
 - **out-of-plane stability** (transverse buckling) is a **governing design parameter** of tied arches
- Transverse stability can be ensured by:
 - **transverse bracings** between two arch ribs running along the outside of the deck
 - **inclined arches connected** at midspan
 - **transverse U-frames** consisting of (stiff) “hangers” and deck (as in classic trough-section girder bridges)
 - **arches with high transverse stiffness** (for short spans)

Fort Pitt bridge, Pittsburgh, USA, 1959. George S. Richardson

$l = 229$ m

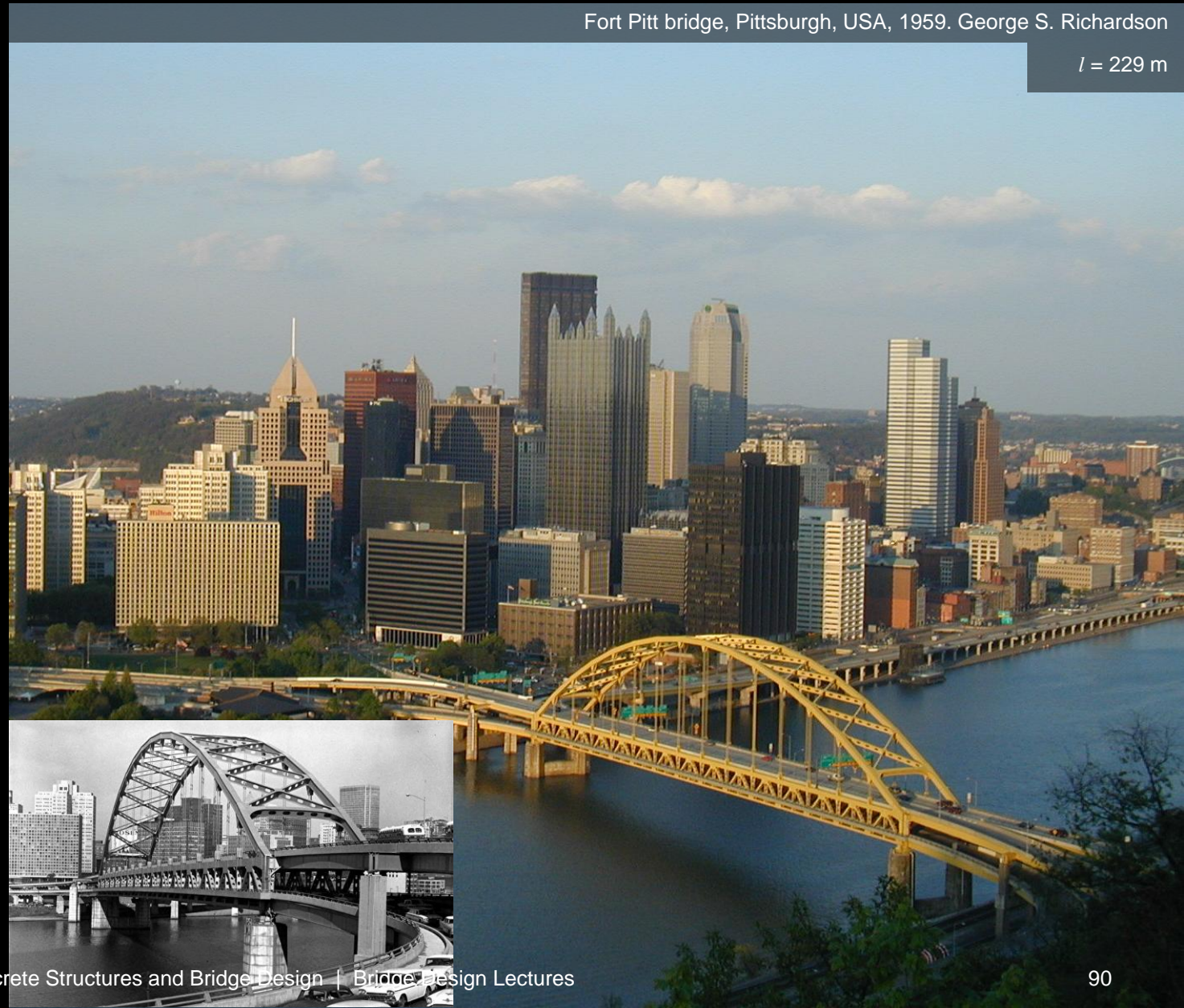

Arch bridge – Design: Tied arch bridges

Tied arches are often steel bridges. The Rheinhauser Brücke in Duisburg is the longest tied arch in Germany (since 1988 “Brücke der Solidarität”).

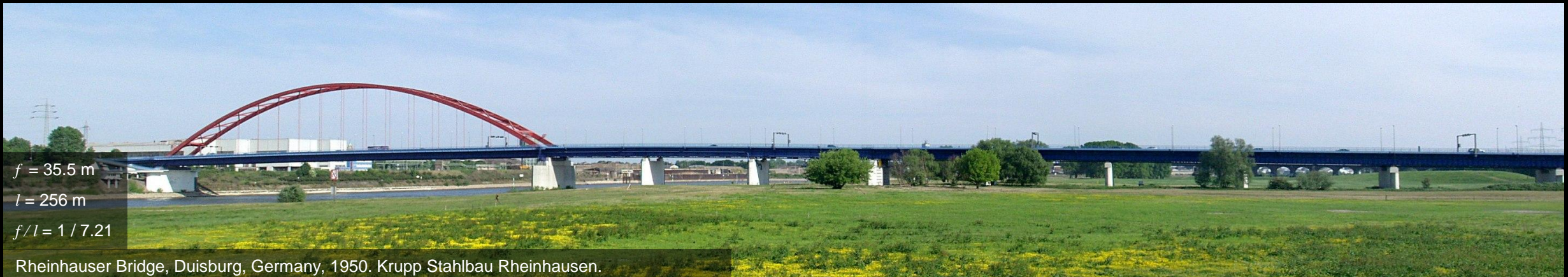

$f = 35.5 \text{ m}$

$l = 256 \text{ m}$

$f/l = 1 / 7.21$

Rheinhauser Bridge, Duisburg, Germany, 1950. Krupp Stahlbau Rheinhausen.

Arch bridge – Design: **Tied arch bridges**

The Barqueta Bridge was the first tied arch with one central arch rib above the roadway (rather than joining two continuous arch ribs).

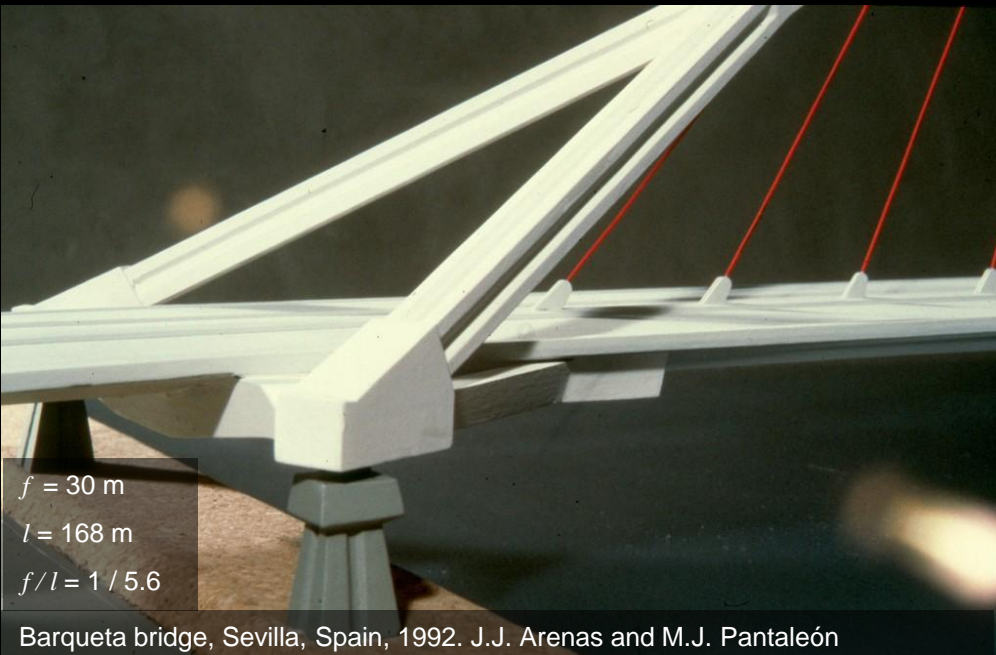
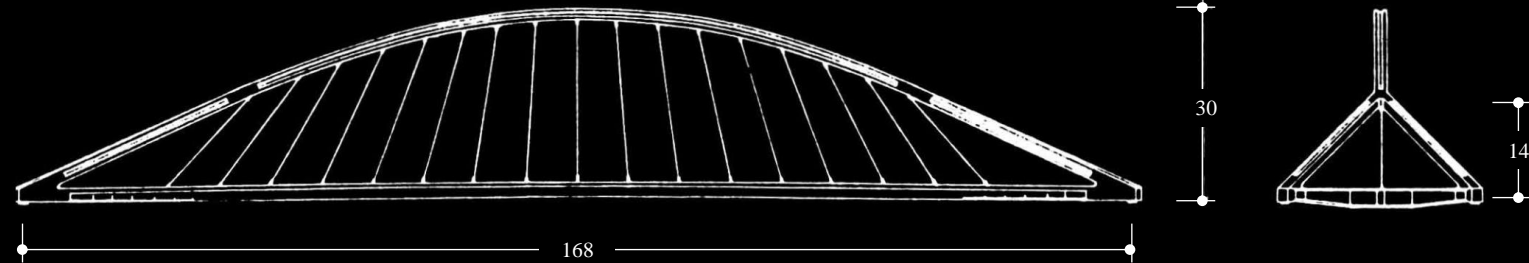

Arch bridge – Design: Tied arch bridges

Concrete tied arch bridges are less frequent. The Puente del Tercer Milenio in Zaragoza is one of few large-span concrete tied arches.

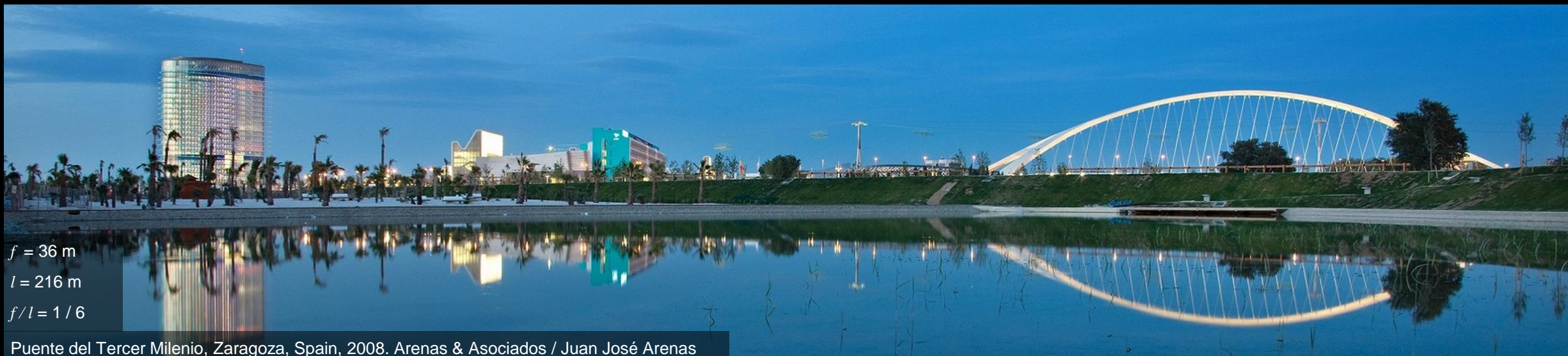

$f = 36 \text{ m}$
 $l = 216 \text{ m}$
 $f/l = 1/6$

Puente del Tercer Milenio, Zaragoza, Spain, 2008. Arenas & Asociados / Juan José Arenas

Arch bridge – Design: Tied arch bridges

- Arches with transverse bracings or connected arch ribs (previous two examples) require a minimum height of the to provide sufficient clearance on the bridge.
- In smaller span arches, such bracings can be eliminated if the “hangers” act as frames, stabilising the arch ribs
→ provide hangers with transverse stiffness
→ transverse frame action of deck-hanger-arch
- Such arches can be very slender, and are attractive to cross as they generate a «curtain effect» to the user (bottom photos).



Arch bridges – Design: **Tied arch bridges**

- Aesthetically, the **elevated arch ribs** of tied arch bridges should be **slender and are thus flexible**
→ stiffness (for non-anti-funicular loads) of tied arch bridges must be ensured by other elements
- Conventionally, **stiff deck girders** were used to ensure sufficient stiffness (previous examples)
- Alternatively, the **hangers can be used** to this end, with the following options
→ Hangers inclined in elevation forming a truss together with arch rib and deck girder
... hangers forming a Warren truss (Strebenzug) without intersections = **Nielsen arch**
... hangers intersecting = **Network tied arch**
→ Stiff “hangers” forming a Vierendeel girder together with arch rib and = **Vierendeel arch**
- **Network tied arches** have gained increasing popularity in the recent years due to their high structural efficiency (photo and next slides).



$l = 71 \text{ m}$

$f/l = 1 / 4.73$

Arch bridge – Design: Tied arch bridges

The Fehmarnsund bridge was the first long-span network tied arch bridge (conversion to local traffic only planned for 2028, new tunnel across Fehmarnsund connecting to Fehmarnbelt).

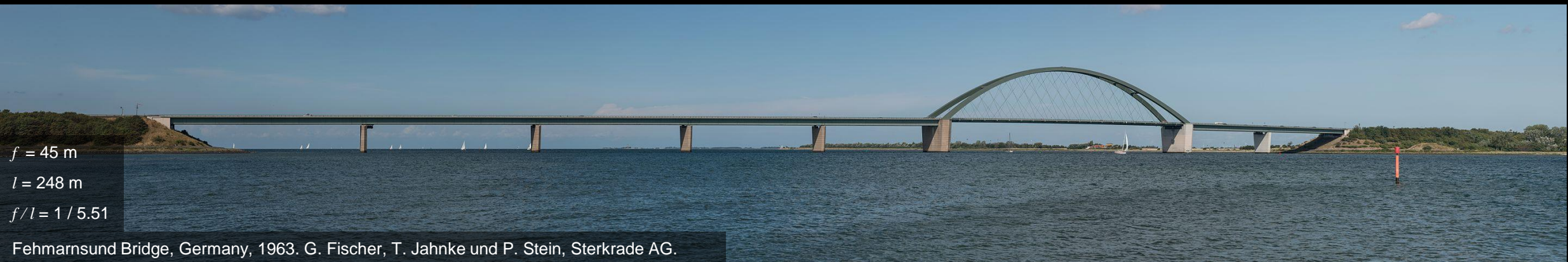

Arch bridge – Design: Tied arch bridges

- Network tied arch bridges are **very efficient** and can thus be used for very **long spans**.
- They are **aesthetically attractive** and very economical if an **efficient erection method** can be used.
- The slide shows the currently longest span network arch bridge.



$f = 75 \text{ m}$
 $l = 380 \text{ m}$
 $f/l = 1 / 5.1$

Bugrinsky bridge, Novosibirsk, Russia, 2014. Albert Koshkin / Sibmost

Arch bridge – Design: Tied arch bridges

- Thanks to their efficiency, network tied arch bridges can be designed **extremely slender and lightweight** (photos).
- However, they are **challenging for analysis and detailing**
 - **sign reversals** in the hanger forces, resulting in sagging hangers, **must be avoided** (critical for high live load to dead load ratio and flat hangers)
 - hangers are prestressed, analysis needs to account for **hanger preload** (similar as in cable-stayed bridges)
 - steep hangers are **prone to fatigue** (high load variation due to slender deck)
 - hanger arrangement requires **complicated details** (no standard connections)
- For these reasons, designers were reluctant using this efficient bridge typology for many decades.
- However, with **modern analysis, drafting and fabrication methods**, these challenges can be mastered.



Brandanger Bridge, Norway, 2010. Aas-Jakobsen.

Arch bridge – Design: **Tied arch bridges**

Vierendeel arches have only been used in few bridges, despite a large number of such bridges being built in Belgium in the 1930s over the Albert Canal.



Gellik Railway Bridge (Spoorbrug bij Gellik), Albert Canal, Belgium, 1934. Span 112.75 m



Lanaye Bridge, Albert Canal, Belgium, 1932. Span 68 m

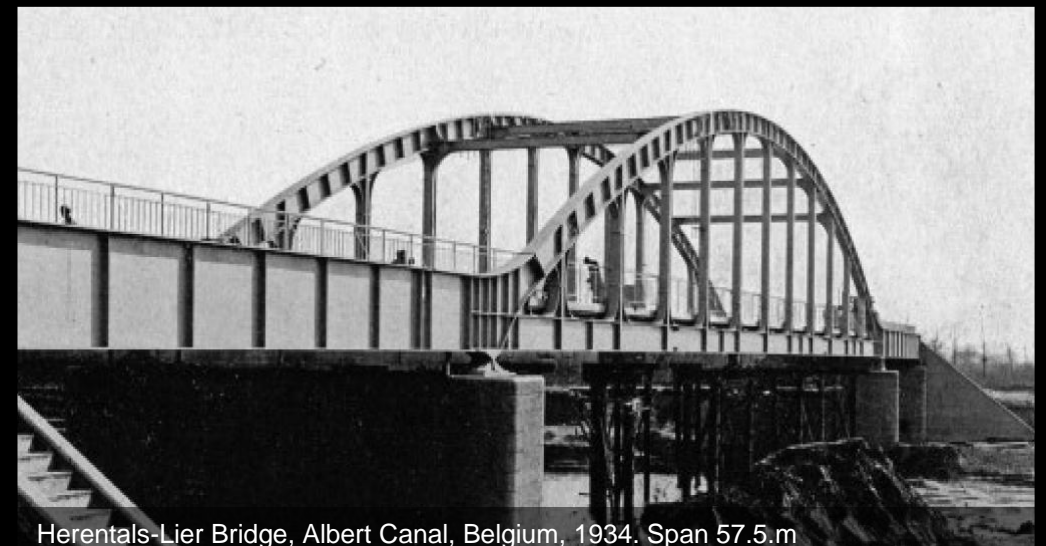

Herentals-Lier Bridge, Albert Canal, Belgium, 1934. Span 57.5 m

Arch bridges

Design – **Through arch bridges**

Arch bridge – Design: **Through arch bridges**

- The **logic of form** is a strong positive point of **deck arches** – which are obviously true arches.
- At least to structural engineers, the force flow is equally clear in **tied arches** (laymen often think they are true arches).
- In **through arches**, however, it is often **impossible to tell whether they act as true or tied arches**, even to experienced bridge designers, without closely inspecting the bridge ends or even consulting drawings.
- As an example, consider the Castelmoron Bridge:
 - **well-known bridge** (as it is one of the few original Nielsen arch bridges) in the bridge community
 - arch exhibits no kink at the hinges at deck level: indicates that any **tie force in the deck girder would be continuous** (equal in main span and adjoining part of the bridge)
 - but the adjoining part of the bridge **might act as V-struts**



Arch bridge – Design: **Through arch bridges**

- Few bridge designers would thus bet much on how this bridge carries the loads without knowing more.
- Only a **virtual visit to the bridge** reveals that
 - it is (most likely) **acting as true arch**, as there is no element that could transfer the arch thrust from the springing line back up to the girder
 - its soffit is also worth having a closer look



Arch bridge – Design: **Through arch bridges**

- When designing a through arch, which makes sense in many cases (clearances vs road alignment), it should be ensured that the force flow is legible.
- This slide shows a clear example of a **through arch acting as true arch**.

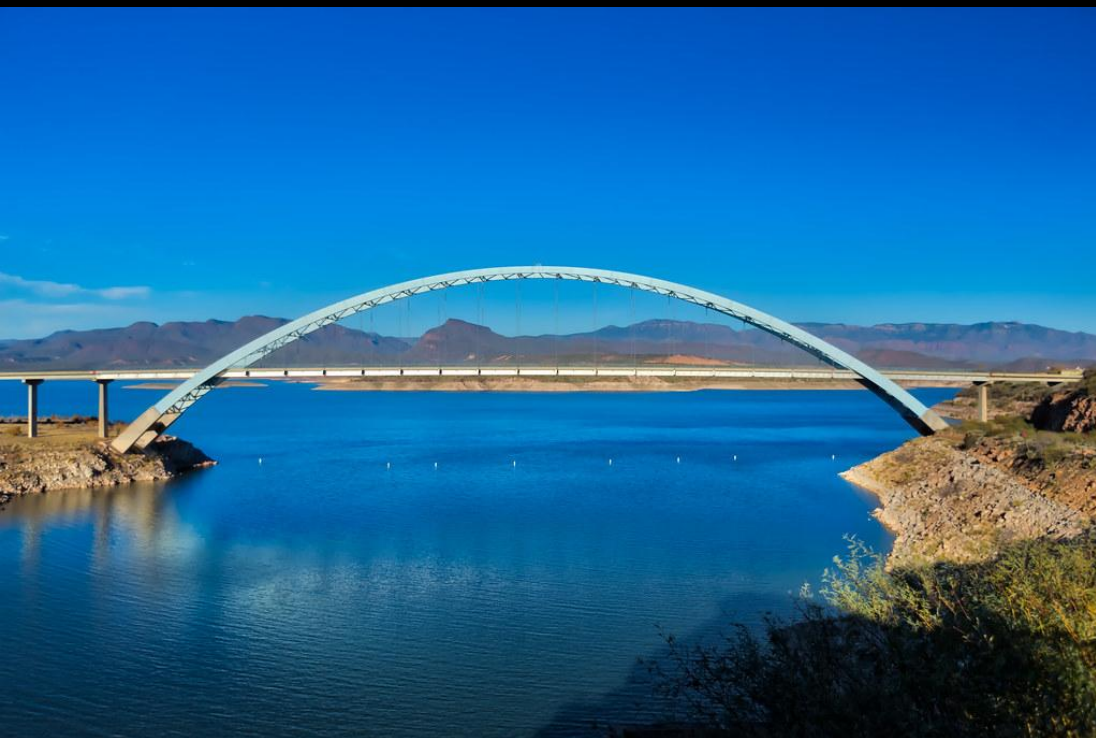

$l = 329 \text{ m}$

$f/l = 1 / 4.7$

Theodore Roosevelt lake bridge, Arizona, USA, 1990. Howard, Needles, Tammen & Bergendoff

Arch bridge – Design: **Through arch bridges**

- This slide shows an equally clear example of a **through arch acting as tied arch on V-struts**.

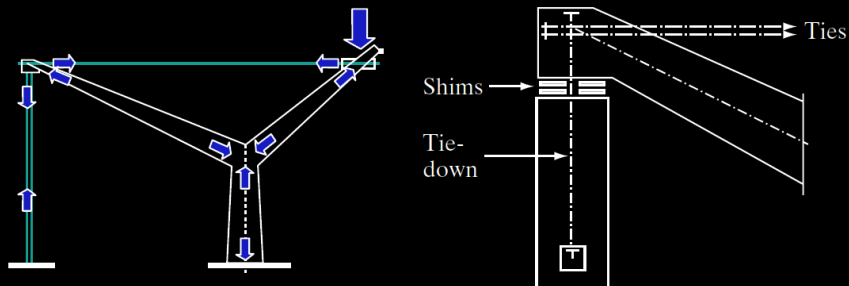
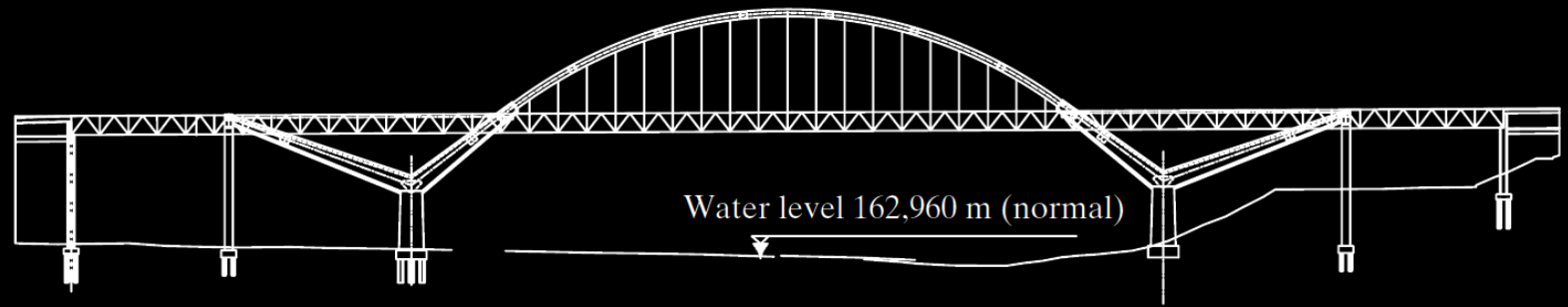

Arch bridges

Structural response

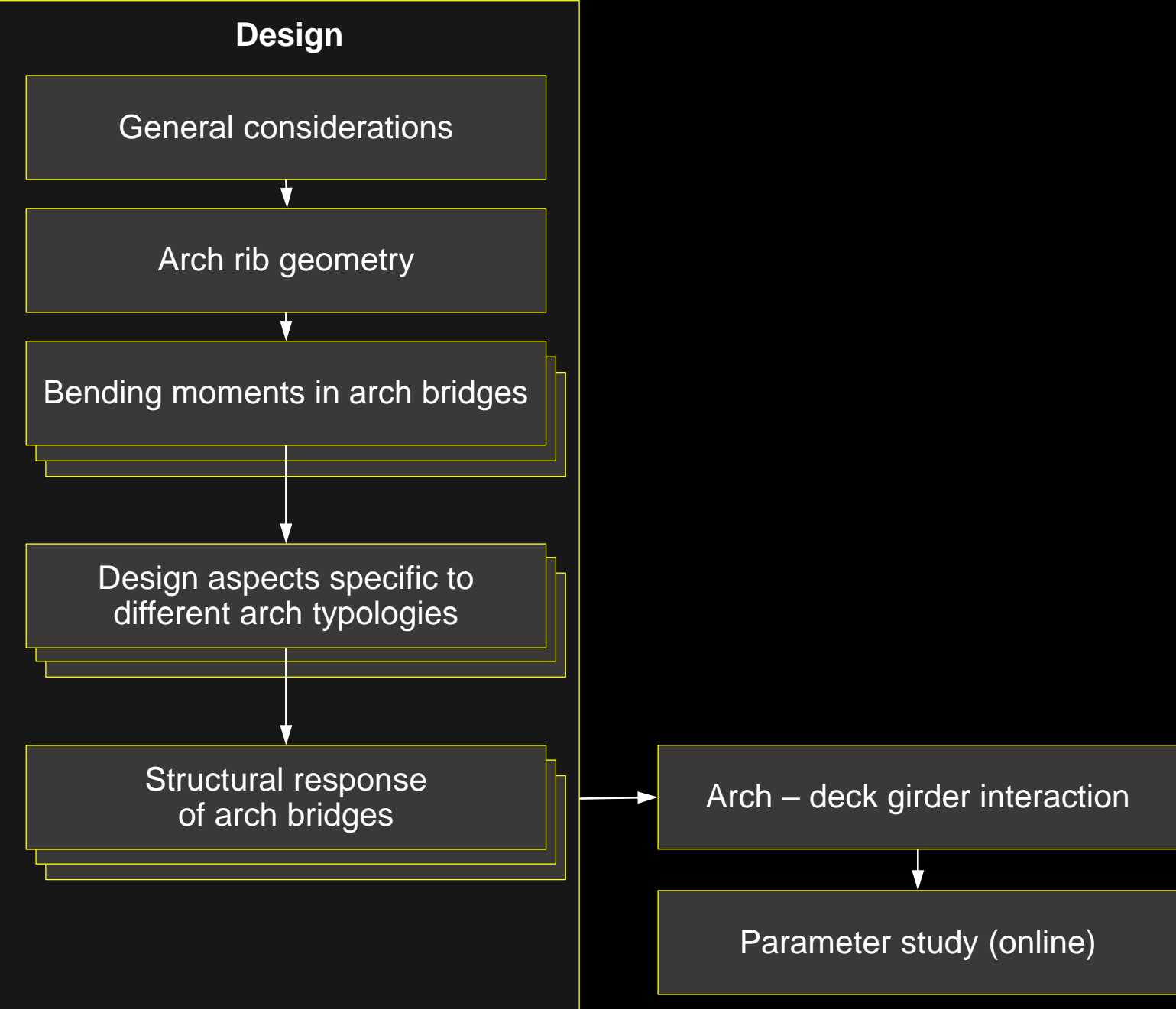

Arch bridges

Structural response – Arch-deck girder interaction

Arch bridges – Structural response: Arch-deck girder interaction

If an **anti-funicular arch geometry** is chosen, usually for permanent loads, arch bridges carry the corresponding loads efficiently.

However, **non-anti-funicular loads need to be accounted** for in design. Under such loads, the arch – arch rib, deck girder and spandrel columns or hangers – act as a **frame system**, whose behaviour depends on

- the **stiffness ratio of arch rib and deck girder**
- the **type of connection between arch rib and deck girder** (clamped or pin-jointed spandrel columns resp. “hangers” – see notes)

To better understand the behaviour, the bending moments in the frame system can be subdivided into two components:

- **fixed system**
- **flexible system**

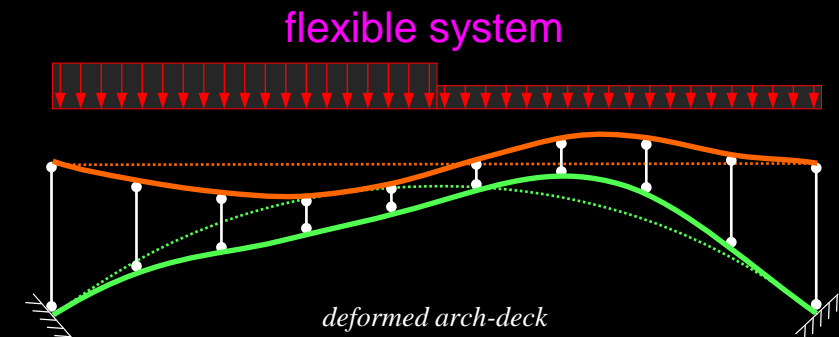
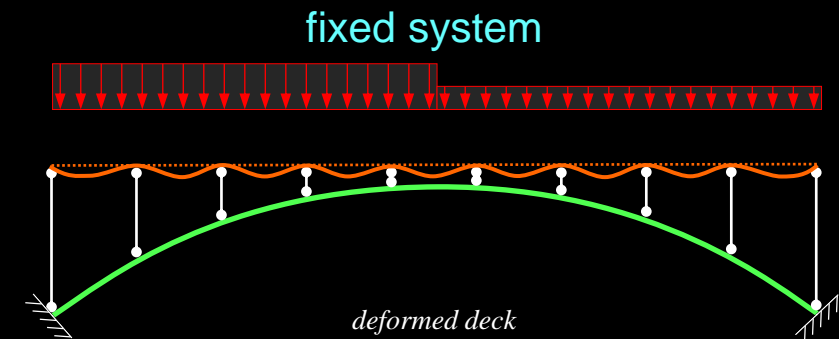

Arch bridges – Structural response: Arch-deck girder interaction

The following points have essentially been outlined in the *Design section*. Here, they are repeated and a *case-study* is presented to highlight some specific aspects.

- **fixed system**

- assume a perfectly rigid arch

- **bending moments in deck girder** corresponding to those in a **continuous beam** (replacing spandrel columns by supports).

- **flexible system**

- bending moments in the flexible system **involve arch deflections** due to non-anti-funicular loads

- generally, these **bending moments are shared by arch rib and deck girder** in proportion to their bending stiffnesses

- two ideal limiting cases can be considered:

- **deck-stiffened arches** (“*versteifter Stabbogen*”), where the entire flexible system moments are resisted by the deck girder (“*Versteifungsträger*”)

- **stiff arches** resisting the entire flexible system moments alone

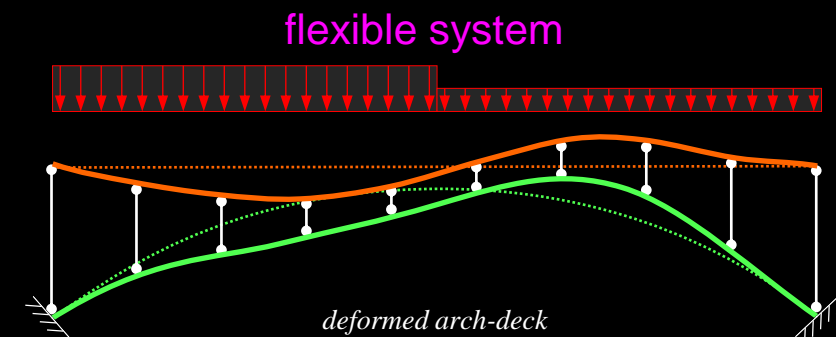
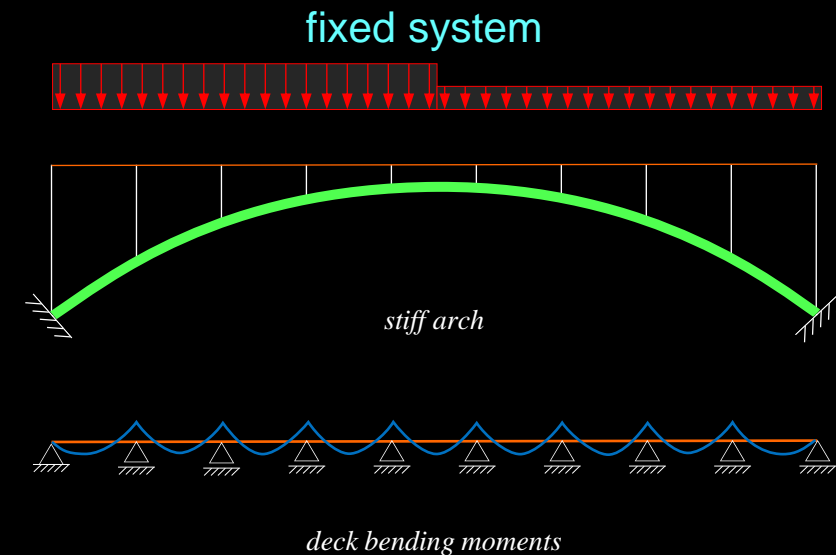

Arch bridges – Structural response: Arch-deck girder interaction

In this study, a **clamped deck-arch bridge**, with expansion joints of the deck above the arch abutments (intersection of springing line with arch axis) is considered (unlike Slide 63: deck continuous).

In the first part, **pin-jointed spandrel columns** are assumed.

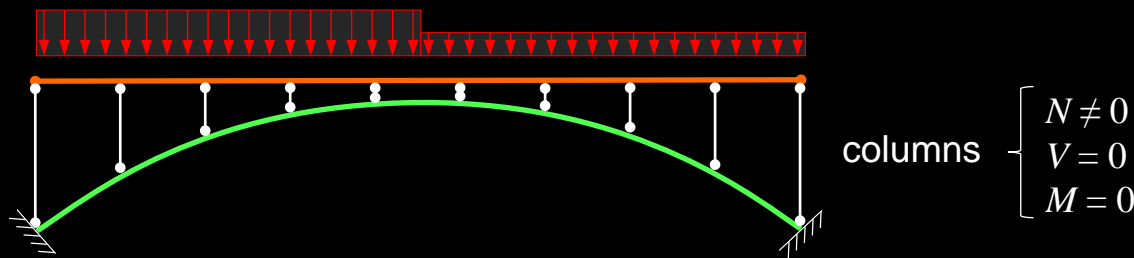

Two limiting cases:

- **deck-stiffened arch**
→ flexural deck girder stiffness $EI^D \gg$ flexural arch rib stiffness EI^A
- **stiff arch**
→ flexural arch rib stiffness $EI^A \gg$ flexural deck girder stiffness EI^D

In these limiting cases, either the **stiffening girder** or the **stiff arch** resists (almost) the entire bending moments.

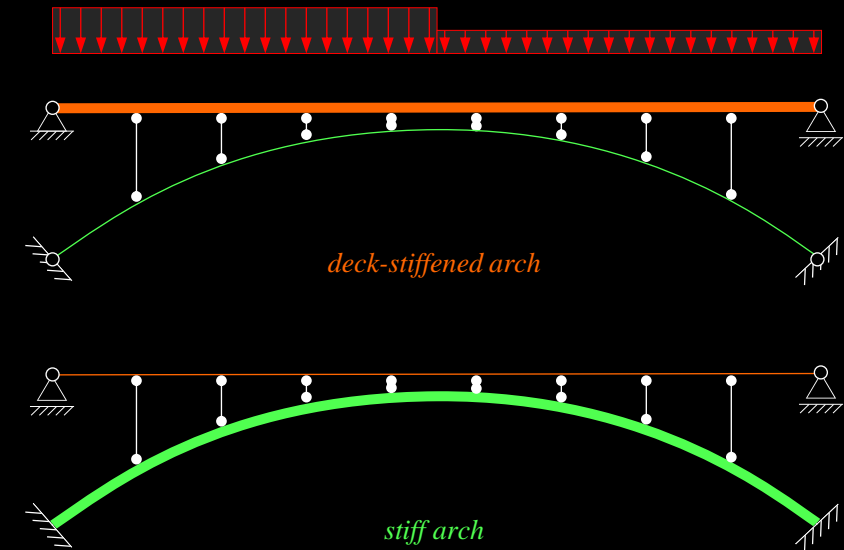

Arch bridges – Structural response: Arch-deck girder interaction

In this study, a **clamped deck-arch bridge**, with expansion joints of the deck above the arch abutments (intersection of springing line with arch axis) is considered (unlike Slide 63: deck continuous).

In the first part, **pin-jointed spandrel columns** are assumed.

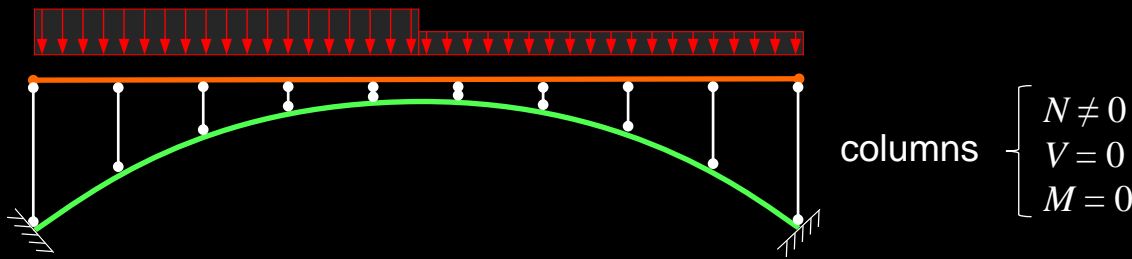

Two limiting cases:

- **deck-stiffened arch**
→ flexural deck girder stiffness $EI^D \gg$ flexural arch rib stiffness EI^A
- **stiff arch**
→ flexural arch rib stiffness $EI^A \gg$ flexural deck girder stiffness EI^D

In these limiting cases, either the **stiffening girder** or the **stiff arch** resists (almost) the entire bending moments.

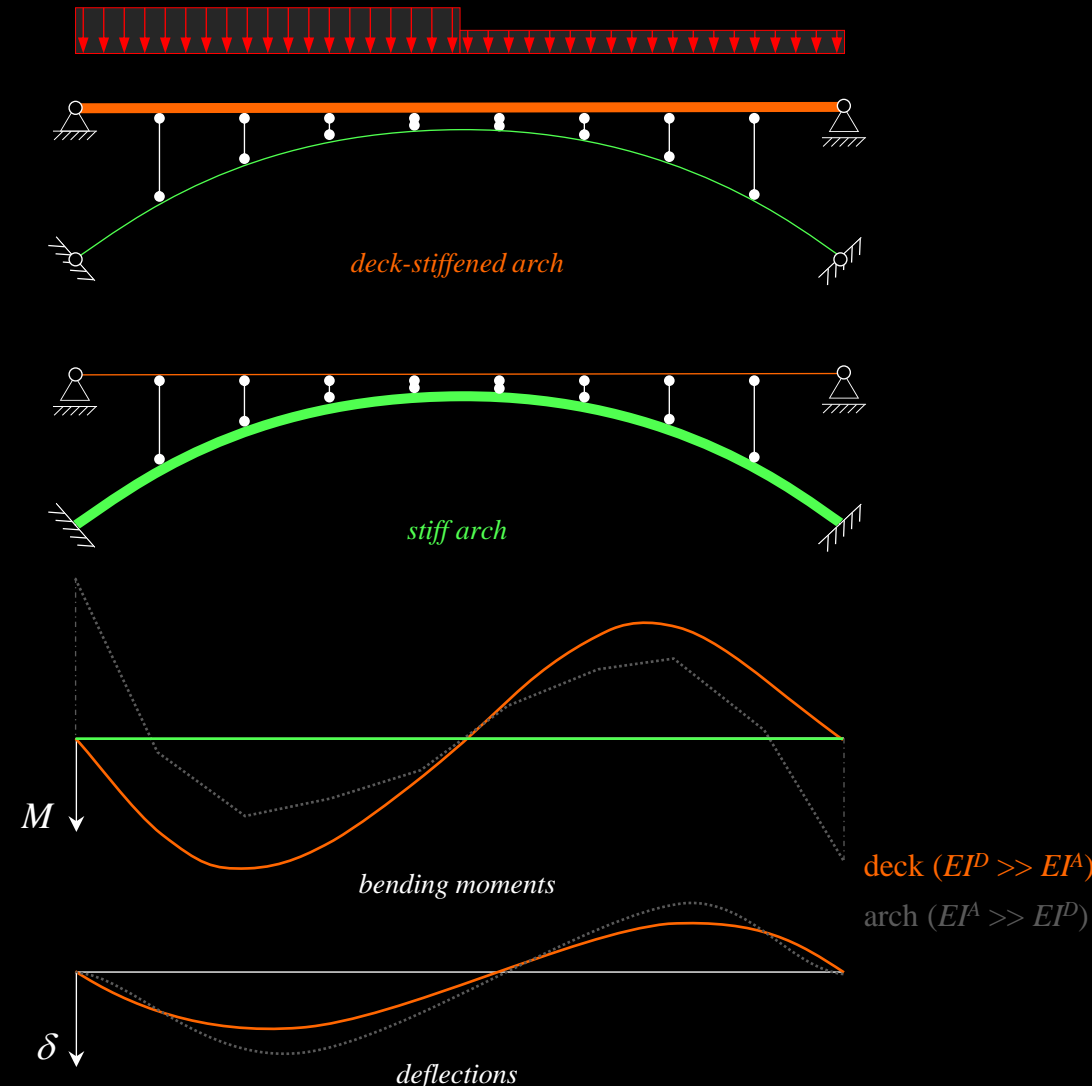

Arch bridges – Structural response: Arch-deck girder interaction

In this study, a **clamped deck-arch bridge**, with expansion joints of the deck above the arch abutments (intersection of springing line with arch axis) is considered (unlike Slide 63: deck continuous).

In the first part, **pin-jointed spandrel columns** are assumed.

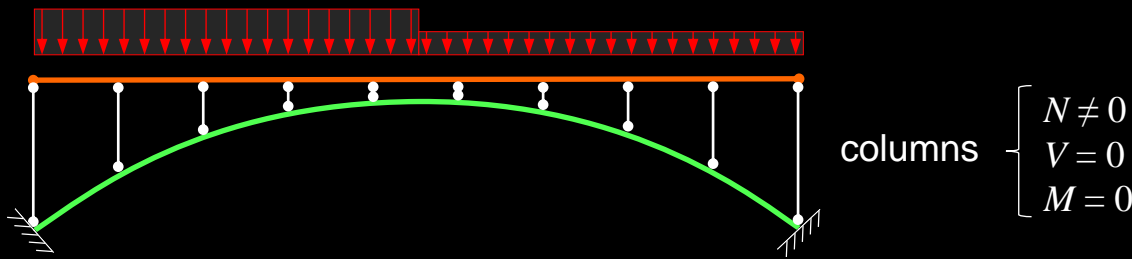

Two limiting cases:

- deck-stiffened arch
→ flexural deck girder stiffness $EI^D \gg$ flexural arch rib stiffness EI^A
- stiff arch
→ flexural arch rib stiffness $EI^A \gg$ flexural deck girder stiffness EI^D

In these limiting cases, either the **stiffening girder** or the **stiff arch** resists (almost) the entire bending moments.

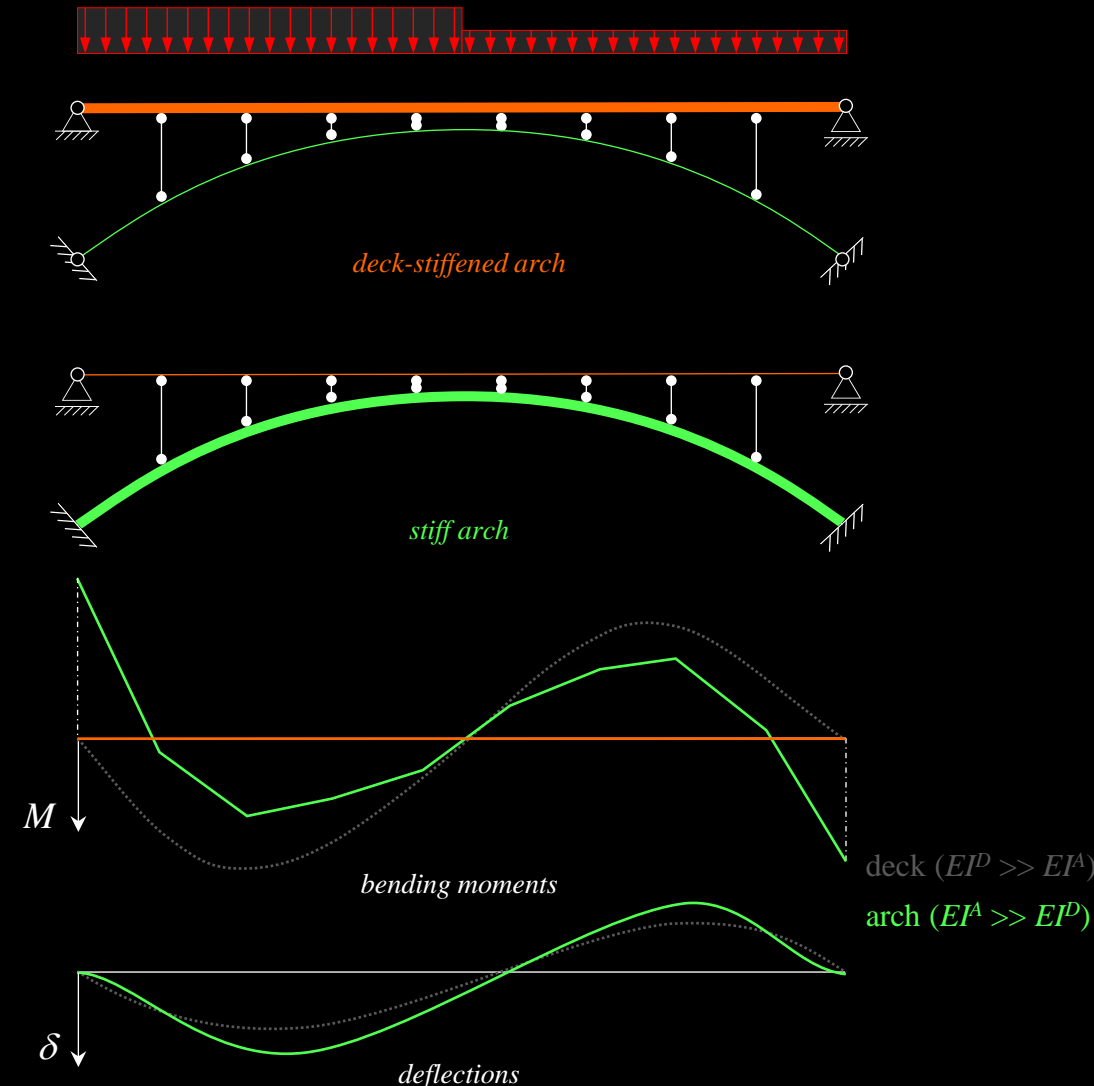

Arch bridges – Structural response: Arch-deck girder interaction

In this study, a **clamped deck-arch bridge**, with expansion joints of the deck above the arch abutments (intersection of springing line with arch axis) is considered (unlike Slide 63: deck continuous).

In the first part, **pin-jointed spandrel columns** are assumed.

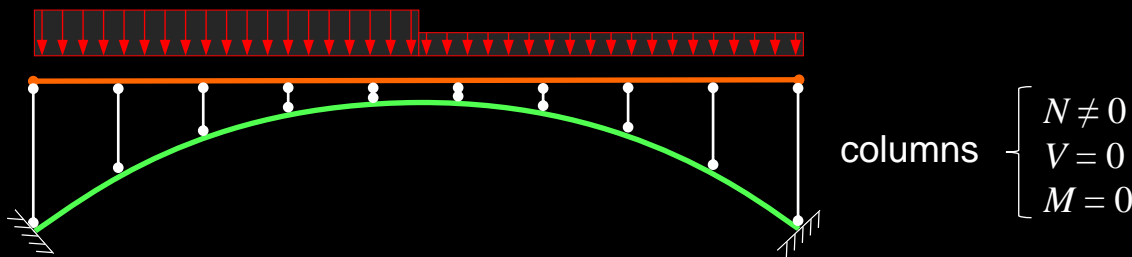

Two limiting cases:

- **deck-stiffened arch**
→ flexural deck girder stiffness $EI^D \gg$ flexural arch rib stiffness EI^A
- **stiff arch**
→ flexural arch rib stiffness $EI^A \gg$ flexural deck girder stiffness EI^D

In these limiting cases, either the **stiffening girder** or the **stiff arch** resists (almost) the entire bending moments.

The differences of bending moments and deflections between arch rib and deck girder are due to the different support conditions assumed here (clamped vs. simply supported). In the design section (Slide 63), both are assumed to be continuous.

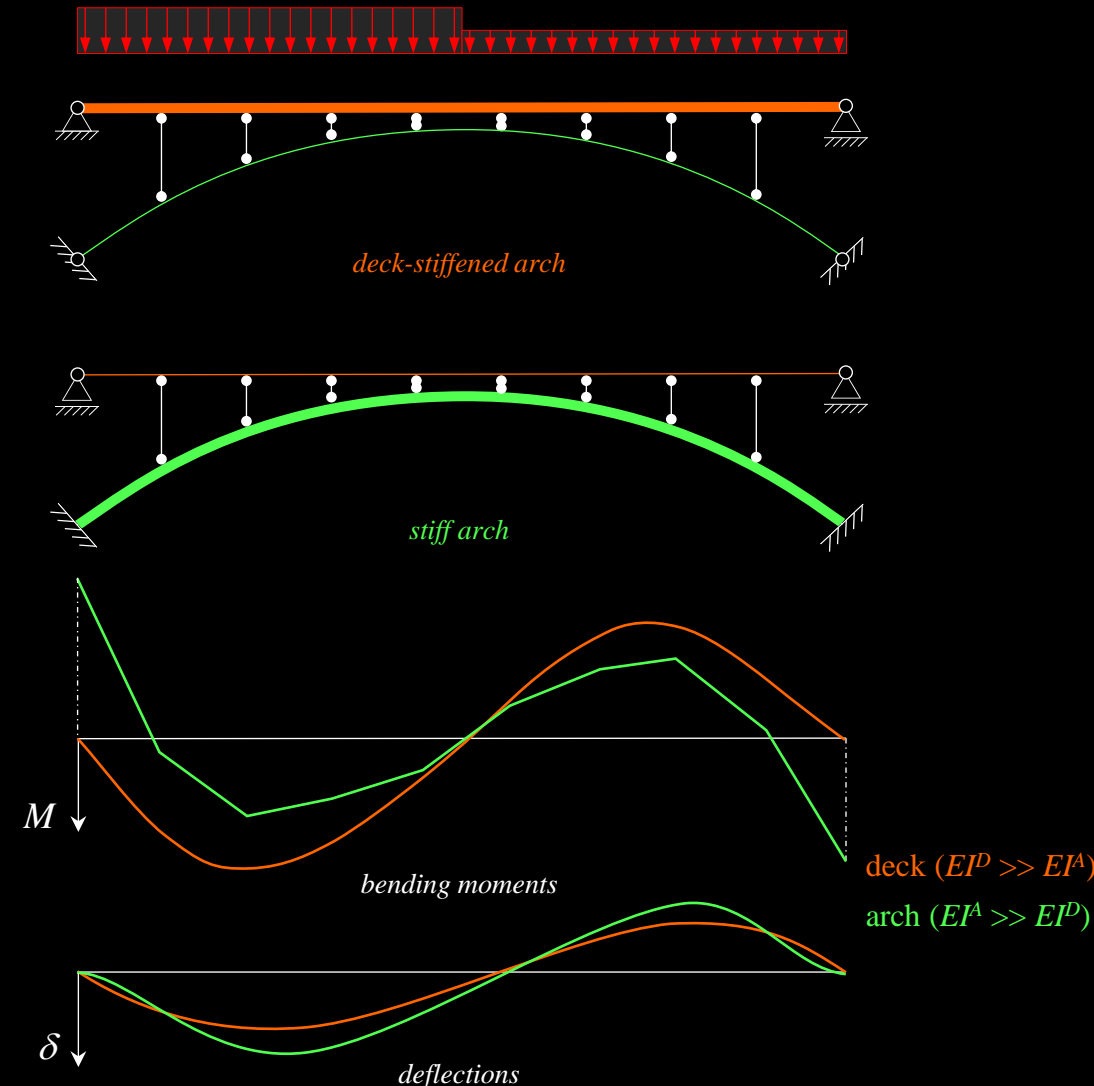

Arch bridges – Structural response: Arch-deck girder interaction

If the **spandrel columns are clamped**, rather than pin-jointed, arch rib and deck are not only coupled in terms of vertical deformations, but act as **frame system**.

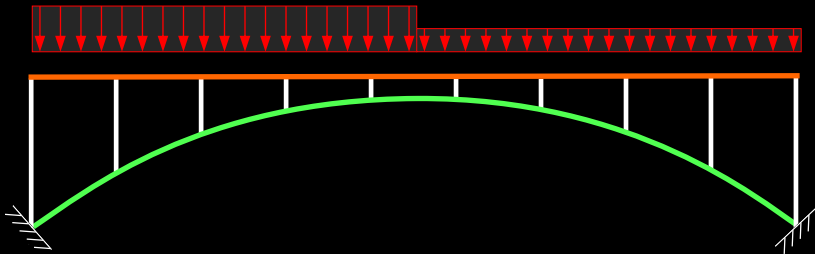

Clamped spandrel columns, together with deck girder and arch rib, act as **Vierendeel girder**

- significantly stiffer than sum of deck girder and arch stiffness
- deflections significantly reduced

The **short clamped spandrel columns** close to the crown have a **high flexural stiffness** and transfer the axial normal force from the arch rib to the deck.

In some cases, **shear forces and bending moments in such spandrel columns may be excessive** → (concrete) hinges may be provided to reduce these actions (e.g. Tamina bridge)

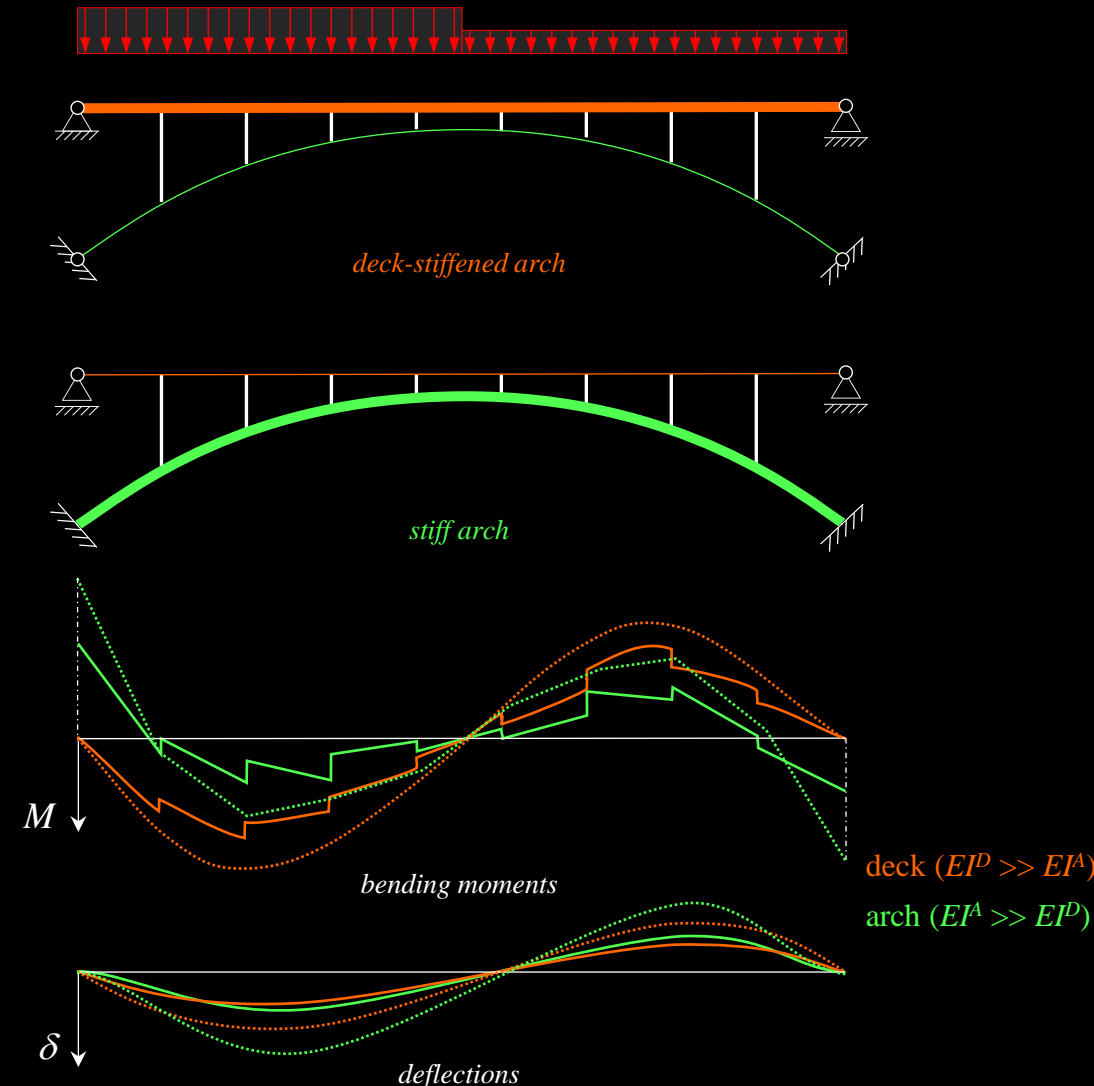

Arch bridges – Structural response: Arch support conditions / hinges

Effect of rise-to-span ratio f/l on bending moments

Here, a **uniform permanent load g** and a **linear analysis** is used. The arches considered are:

- **two-hinged arch**
- **clamped arch**

Using these assumptions and equations in the numerical example ($l=100$ m; $h=1.20$ m; $DL = 140$ kN/m), the following results are obtained (see graphs):

- The rise-span ratio f/l is highly relevant, having a strong impact on structural behaviour, particularly for small values of f/l (low arches)
- Bending moments increase exponentially with smaller values of f/l , particularly pronounced for $f/l < 1/10$. For $f/l = 1/15$, bending moments are up to 15 times higher than for $f/l = 1/5$.
- The crown displacement also grows progressively as f/l decreases, especially for $f/l < 1/10$
- Clamped and two-hinged arches show similar tendencies.

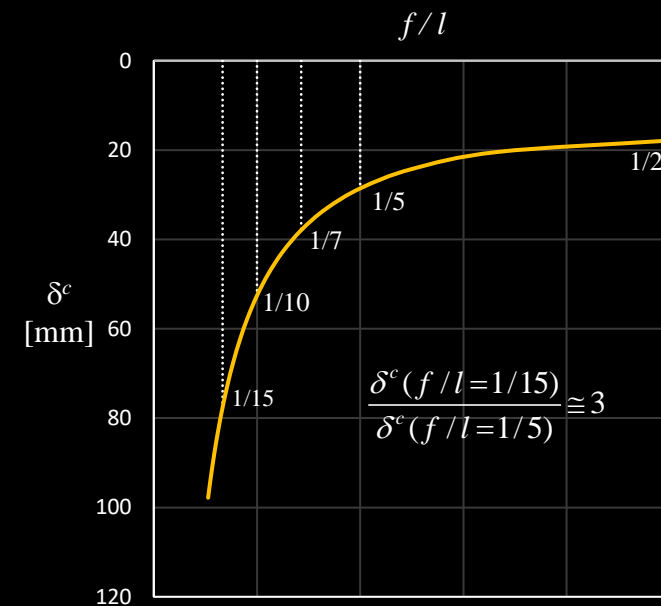
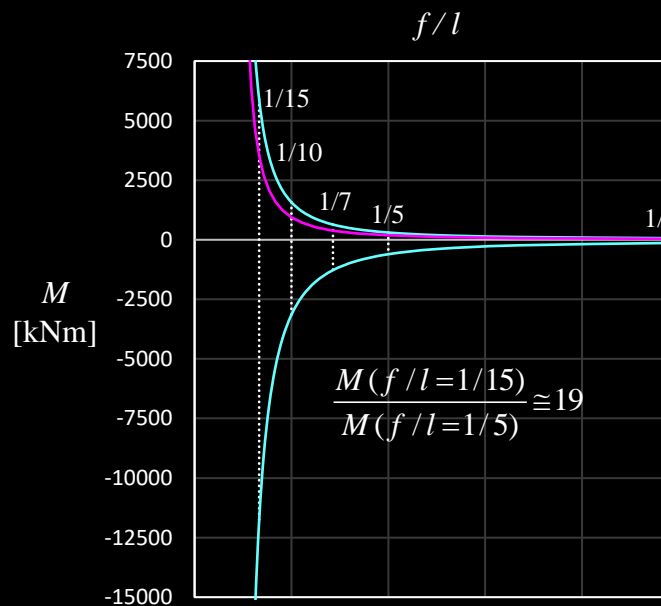
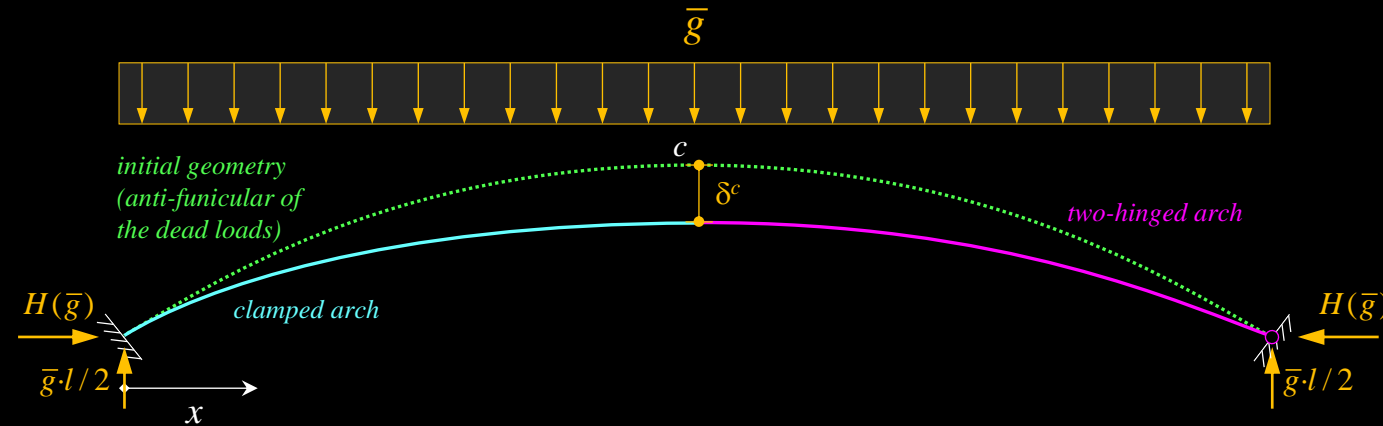

Arch bridges – Structural response: Arch support conditions / hinges

Effect of rise-to-span ratio f/l on bending moments

Here, a **uniform permanent load g** and a **linear analysis** is used. The arches considered are:

- **two-hinged arch**
- **clamped arch**

Note that similar results are obtained when the arches are subjected to **horizontal displacements of the supports**.

The resulting bending moments, for a low arch (rise-span ratio lower than 1/10), may exceed the moments produced by the gravity loads.

Conversely, the influence of imposed deformations are relatively small in arches which rise-span ratios $> 1/7$.

The numerical results correspond closely to the approximation (slide 55) for $EA=\text{const.}$, i.e.

$$\delta^c \cong \frac{H(\bar{g})}{EA^{A,c}} \cdot l \cdot \frac{1+3(f/l)^2}{4f/l} \text{ is a good approximation.}$$

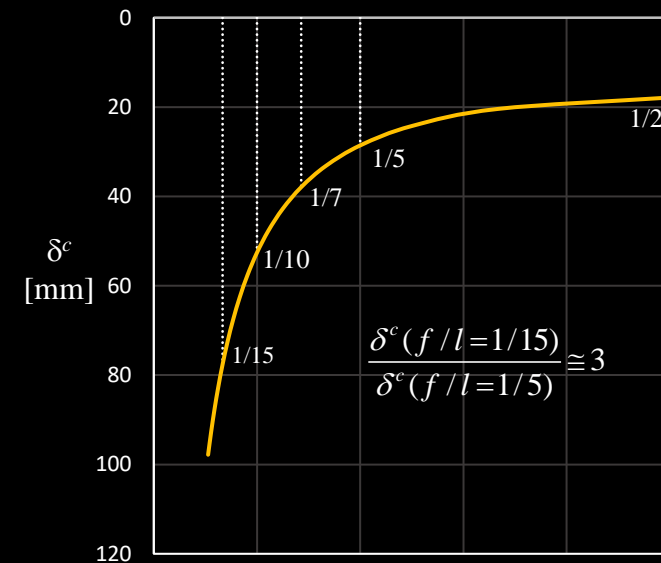
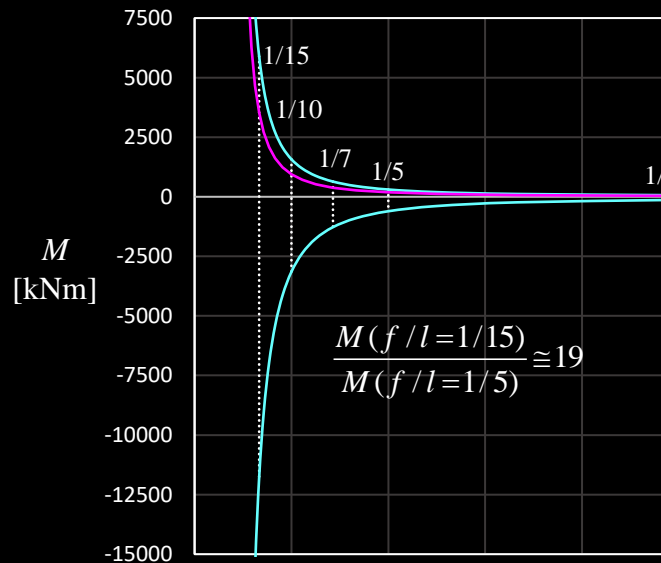
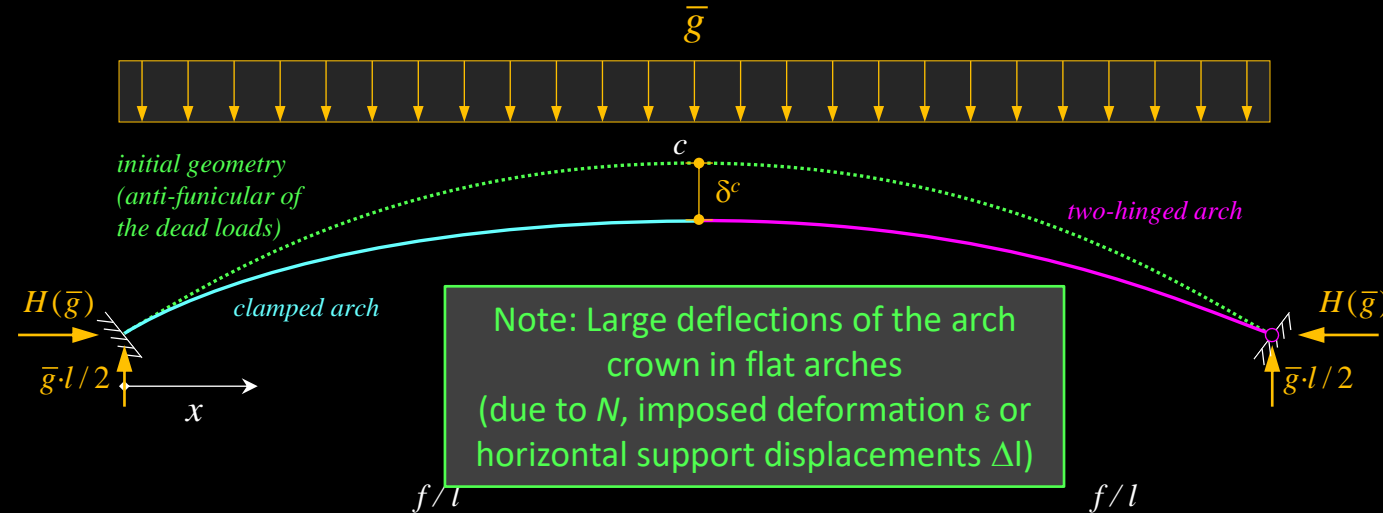

Arch bridges – Structural response: Arch support conditions / hinges

Permanent load + imposed deformation
1st and 2nd order analysis

- reinforced concrete
- three-hinged arches → two-hinged arches
- central span: 72.5 m
- $f/l = 1 / 15$



Le Veudre bridge, France, 1910. Eugène Freyssinet



Arch bridges

Erection methods

Introduction

Historical perspective



Anti-funicularity



Typologies



Design

General considerations



Arch rib geometry



Bending moments in arch bridges



Design aspects specific to different arch typologies



Structural response of arch bridges



Erection methods

General remarks and centrings



Cantilever-constructed steel arches



The Melan System and related methods



Vertical assembly and rotation



Cantilever-constructed concrete arches



Evolution of the Melan System



Final remarks

Arch bridges

Erection methods – **General remarks and centrings**

Arch bridges – Erection methods: **General remarks and centrings**

High relevance of erection method in arch bridges

- The construction process is an essential part of the conceptual design of any bridge
- While arches are very efficient structures in the final configuration
 - the efficient arch action is **only activated once the arch is able to transfer the arch thrust**, i.e., after **closure (Bogenschluss)**
 - the **load transfer during construction differs strongly from that in the final configuration**, undermining economy (see Conceptual Design)
 - the **construction process is particularly relevant** for the economy of arch bridges



$l = 79 \text{ m}$

$f/l = 1/3$

Gmündertobel Bridge, Switzerland, 1908, Emil Mörsch

Arch bridges – Erection methods: **General remarks and centrings**

Stone arches

- For centuries, stone arches have been erected on timber centrings (= arch or dome falsework)
- Information on Roman arch bridges, and more so their centrings, is scarce (Vitruvius gives some information)
- The practice of building stone bridges died out in Europe with the collapse of the Roman empire and only reappeared in the middle age (see notes)

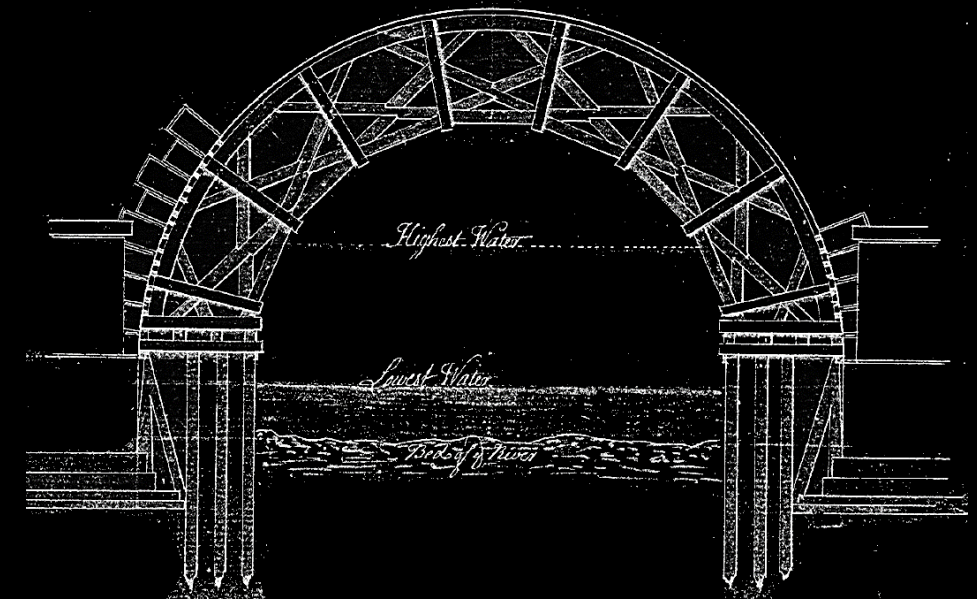

Arch bridges – Erection methods: **General remarks and centrings**



Pflanzgarten Viaduct in construction, Switzerland, 1908

Arch bridges – Erection methods: **General remarks and centrings**

- Though inherently inefficient for large spans (see previous slides), this method was used for the **first concrete arch bridges**, that were indeed “**concrete stone**” arch bridges, using concrete as inexpensive stone surrogate.

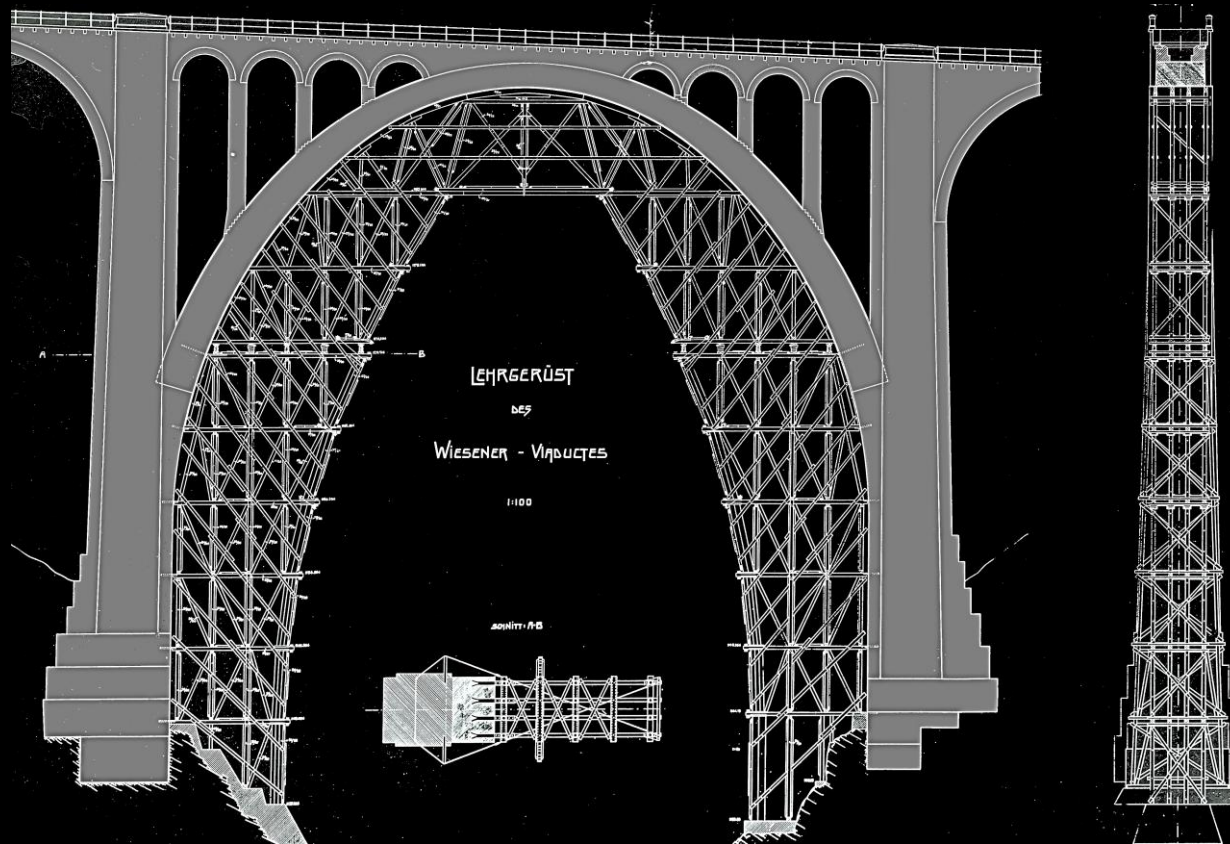

Arch bridges – Erection methods: **General remarks and centrings**

- **Centrings**, often using timber, were **also used for the first reinforced concrete arch bridges**.
- In many cases, the falsework was as attractive, if not even more appealing, than the final structure

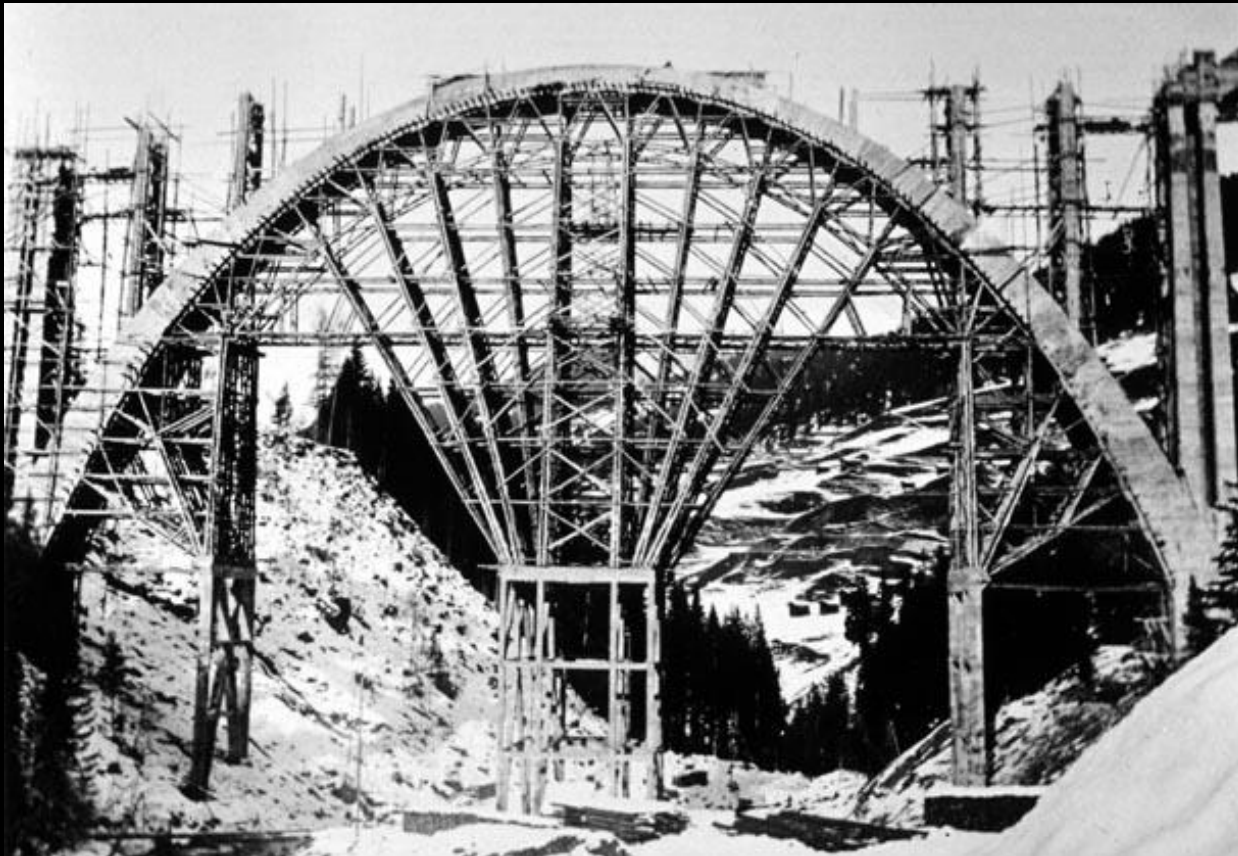

Arch bridges – Erection methods: **General remarks and centrings**

- Timber centrings can also be used for arch **bridges crossing water**. They can be assembled on shore (where the centring can easily be supported) and then floated in as **tied arch**.
- The most prominent example is Freyssinet's **Pont de Plougastel (Pont Albert-Louppe)** crossing the bay of Brest, see photos.
- “Wind deviation” devices (see photo below) were mounted on Freyssinet's iconic bridge after the construction of a modern cable-stayed bridge nearby, to protect the latter from turbulence – a disgrace.



Arch bridges – Erection methods: **General remarks and centrings**

- Large-span timber falsework arches need to be designed and detailed as meticulously as final structures.
- While there were no problems in the Plougastel bridge, the **similar falsework of the Sandö Bridge** – though with a substantially longer span (record concrete arch span at the time) – collapsed on the 31.8.1939. Eighteen construction workers died.
- The bridge was then finally built on a massive falsework with intermediate shoring.



missing parts of arch slab
at collapse of centring

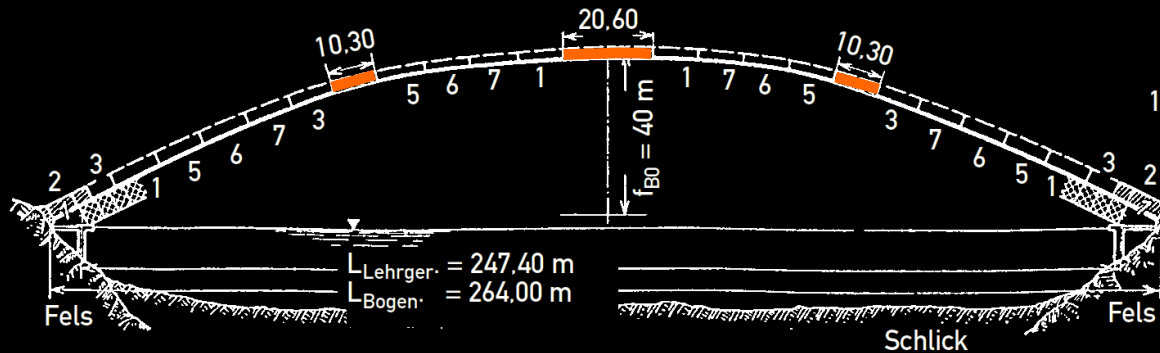

Arch bridges – Erection methods: **General remarks and centrings**

- The **Gladesville Bridge** in Sydney (main span 305) succeeded The Sandö Bride in 1964 as longest span concrete arch bridge.
- While looking similar, the Gladesville Bridge is more slender and featured several innovative construction methods, with a high degree of prefabrication, resulting in a highly efficient construction process (see notes).
- The bridge was designed mainly by T. Gee, a young British engineer (born 1934), and was the last major project in which E. Freyssinet was personally involved.



Arch bridges – Erection methods: **General remarks and centrings**

- Most of the **prominent early concrete arch bridges** were built using remarkable timber centrings.
- This and the following slides show three further extraordinary Swiss examples (Hundwilertobel Bridge, Salginatobel Bridge, Gueroz Bridge).



$l = 105 \text{ m}$
 $f/l = 1/2.9$

Hundwilertobel Bridge, Switzerland, 1925, A. Schläpfer, Ed. Züblin & Cie

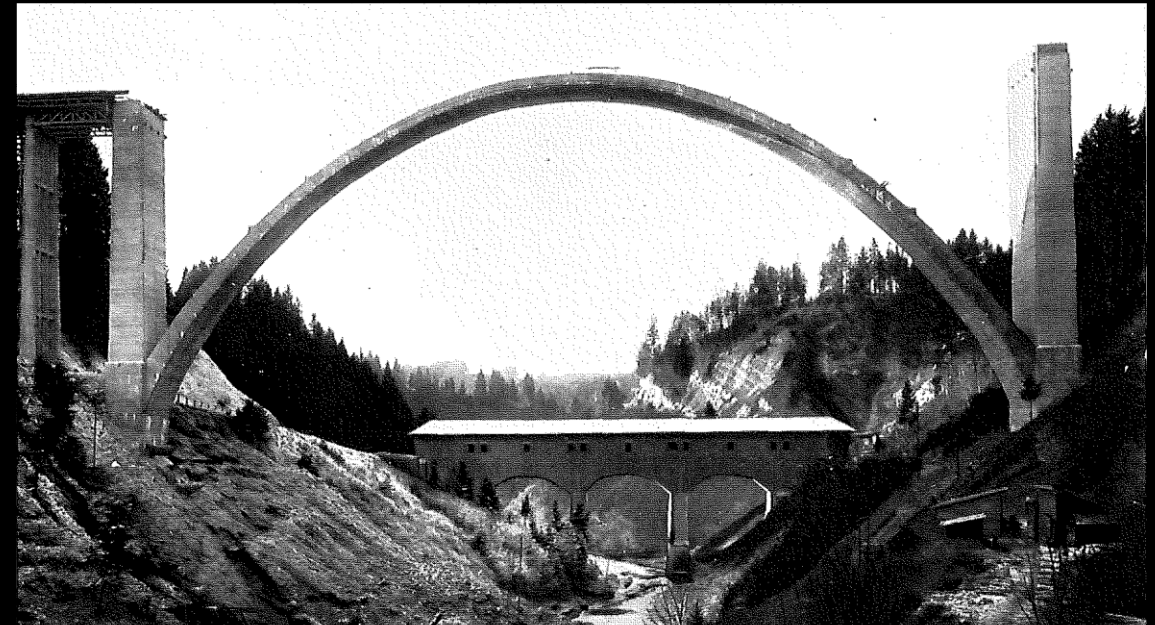

Arch bridges – Erection methods: **General remarks and centrings**

- These centrings were already expensive at the time, but still competitive with other construction methods due to the relatively low labour cost compared to materials, particularly steel.
- **Richard Coray** designed many of these centrings, whose erection was often challenging.

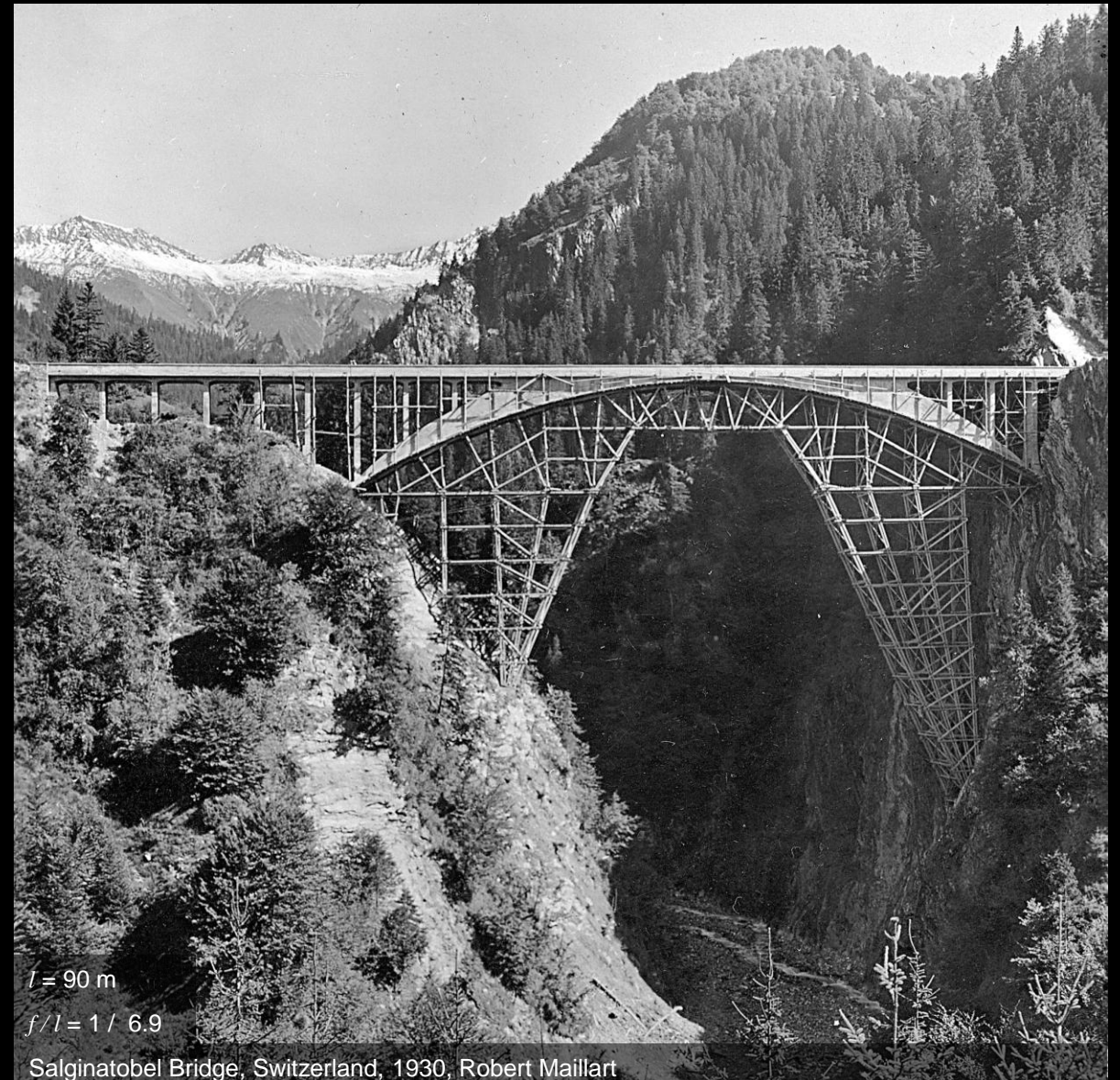

$l = 90 \text{ m}$
 $f/l = 1 / 6.9$

Salginatobel Bridge, Switzerland, 1930, Robert Maillart

Arch bridges – Erection methods: **General remarks and centrings**

- Centrings remained the **preferred construction method of many designers** for reinforced concrete arches until the 1940s, although alternative erection methods existed already (Melan system, see behind).
→ Consequently, only **few reinforced concrete arches with spans above 80, and only a handful above 100 m** were built (see notes).



Arch bridges – Erection methods: **General remarks and centring**

- Economy remained a problem of concrete arches cast on centring, despite **progress in construction and analysis methods** such as casting of the arches in rings (similar to the erection of stone arches in rings, e.g. in the Soliser Viadukt).
- In the **Tara bridge** (aka Đurđevića-Tara Bridge), the arch was **cast in three rings**, enabling a lighter centring (centring by R. Coray).

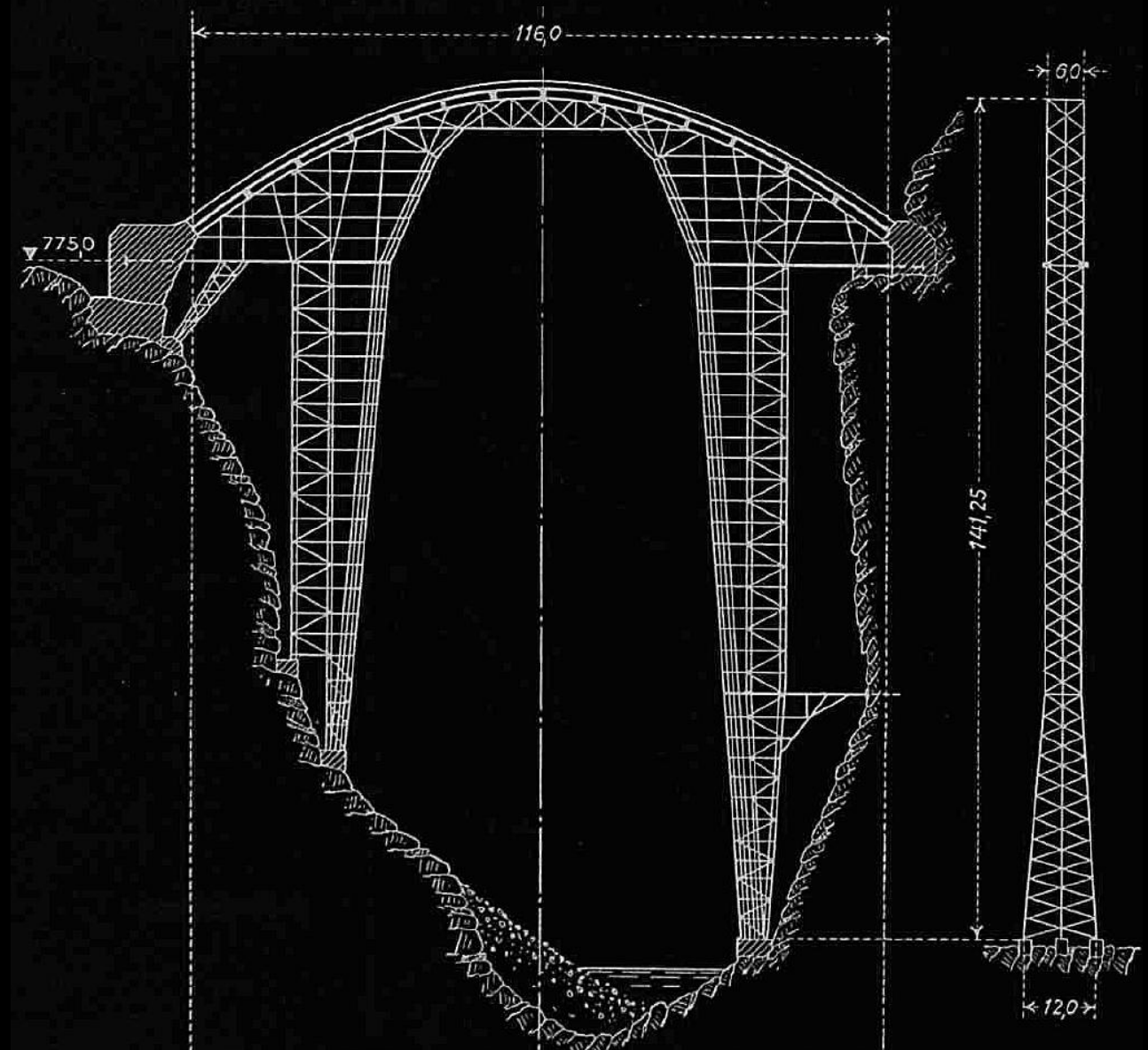

Arch bridges

Erection methods – **Cantilever-constructed steel arches**

Arch bridges – Erection methods: **Cantilever-constructed steel arches**

- On the other hand, for almost 150 years, **steel truss arch bridges have been built by cantilevering**, either with or without temporary supports or stays.
- Typically, they were designed as two- or three-hinged arches to minimise restraint
- The first, prominent example is the **Eads Bridge across the Mississippi**, built by cantilevering (with temporary towers and stays) as early as 1874, with three spans above 150 m.



$l = 159 \text{ m}$

Eads Bridge, USA, 1874, James Eads

Arch bridges – Erection methods: **Cantilever-constructed steel arches**

- In truss arches built by cantilevering without backstays, the arch abutment is clamped during construction, and only free to rotate after closure of the arch. Hence, the upper truss chords
 - are **fully utilised in construction (tension chords)**
 - receive **little load in the final configuration** (they primarily help stabilizing the arch from buckling)
- This is most **obvious at the bridge ends**, where forces during cantilevering are highest, but once the arch is closed, the top chords are virtually (completely in two- or three-hinged arches) stress free
 - such arches are **inherently uneconomical** and, in this respect, **lack logic of form**.
- Using temporary towers and stays during cantilevering as in the **Garabit Viaduct**, the arch can be hinged at its abutments from the beginning, yielding a **much more consistent design in the final configuration**.

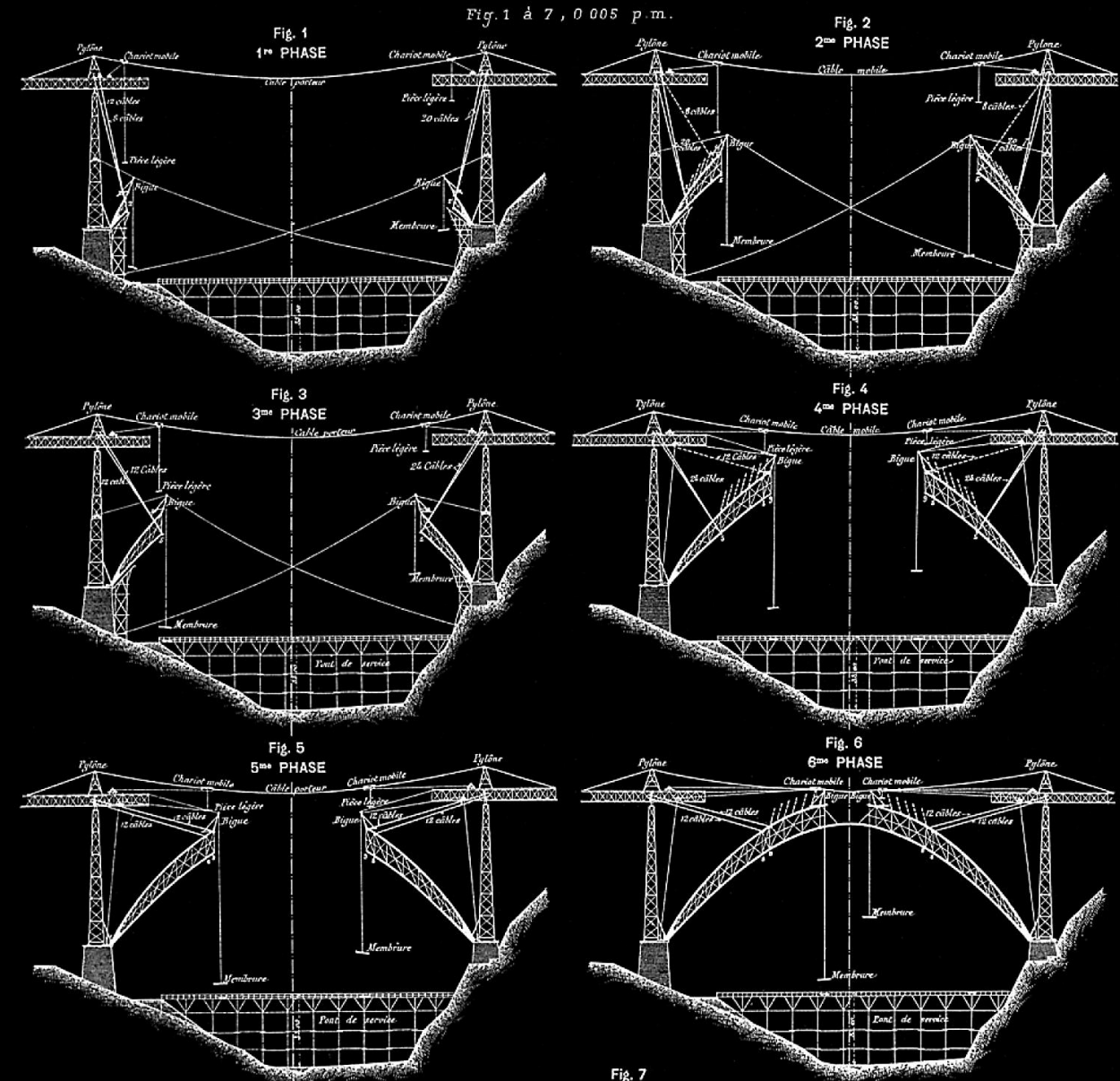

Arch bridges – Erection methods: **Cantilever-constructed steel arches**

- If the arch abutments are hinged from the beginning of construction, the **structural safety during erection fully relies on the temporary towers and stays**
- While this appears more economical, it is certainly less robust. In the following years, steel truss arches were thus frequently cantilevered starting with a **clamped arch** (converted to a hinge after closure) combined with **temporary towers and stays**.



Arch bridges – Erection methods: **Cantilever-constructed steel arches**

- Among the many cantilever-constructed truss arch bridges worldwide, there are several **iconic structures**.
- The **Bayonne Bridge**, across the Kill van Kull strait, designed by Swiss engineer **Othmar Ammann** and his team, set a new arch span record of 511 m when it opened in 1930 (top right photo), that held until 1977.
- In order to increase navigational clearance, the **deck was raised by about 20 m in 2017**, under full traffic during construction – an extraordinary achievement (bottom photos)



Arch bridges – Erection methods: **Cantilever-constructed steel arches**

- The **Sydney Harbour Bridge**, with a slightly smaller span of 503 m, is another, perhaps even more iconic steel truss arch bridge.
- While temporary supports in the Kill van Kull were used in the former, the Sydney Harbour Bridge was built **by cantilevering without temporary towers nor stays**.
- In turn, **massive temporary steel support cables running in tunnels** were used during construction (128 cables @ 1.2 MN each (tested to 5 MN)).

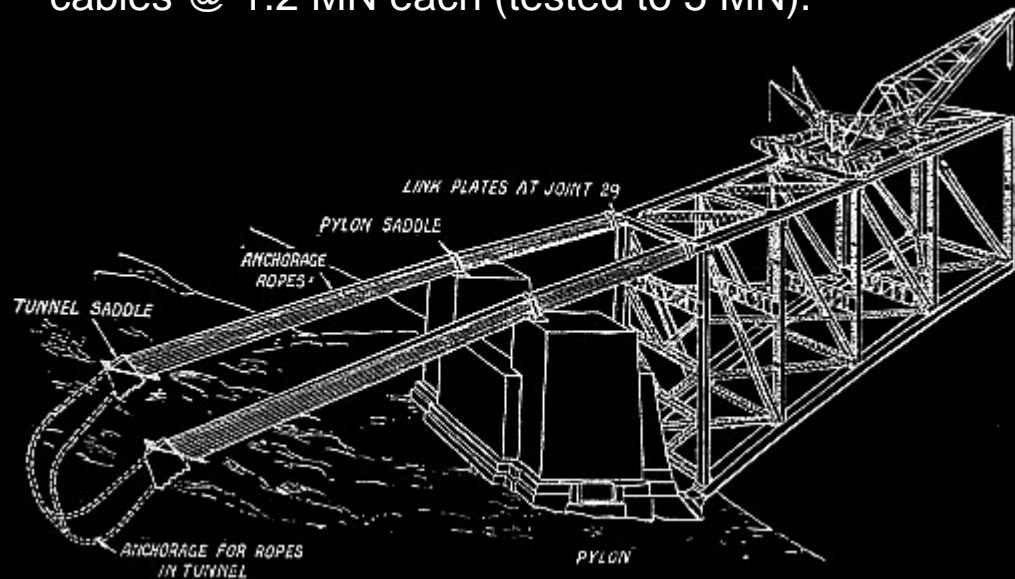

Arch bridges – Erection methods: **Cantilever-constructed steel arches**

- The **New River Gorge Bridge**, West Virginia, set a new arch span record (518 m) in 1977, that held until 2012.
- While the Bayonne Bridge and the Sydney Harbour Bridge are through arches – though the full arch thrust is resisted by the foundations –, the New River Gorge Bridge is a **deck arch**.
- This enabled using stays extending from the deck above the abutment (figure), similar as in the Garabit viaduct, and building the arch hinged at abutments.
- Other than in Garabit, the arch segments were transported via a cableway system (Seilkran).

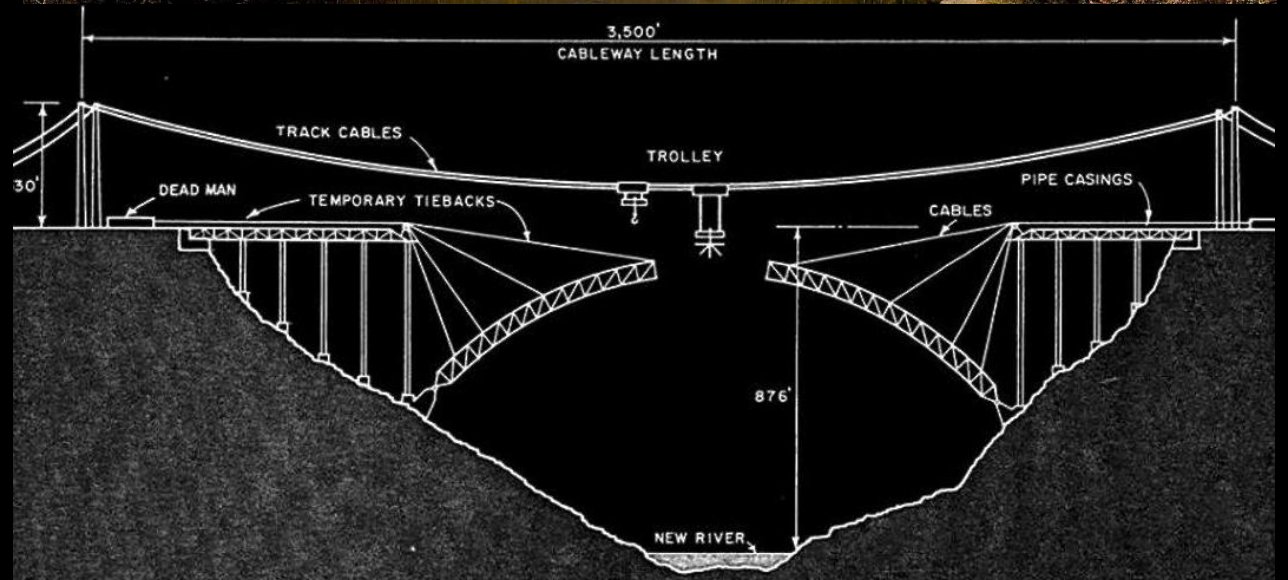
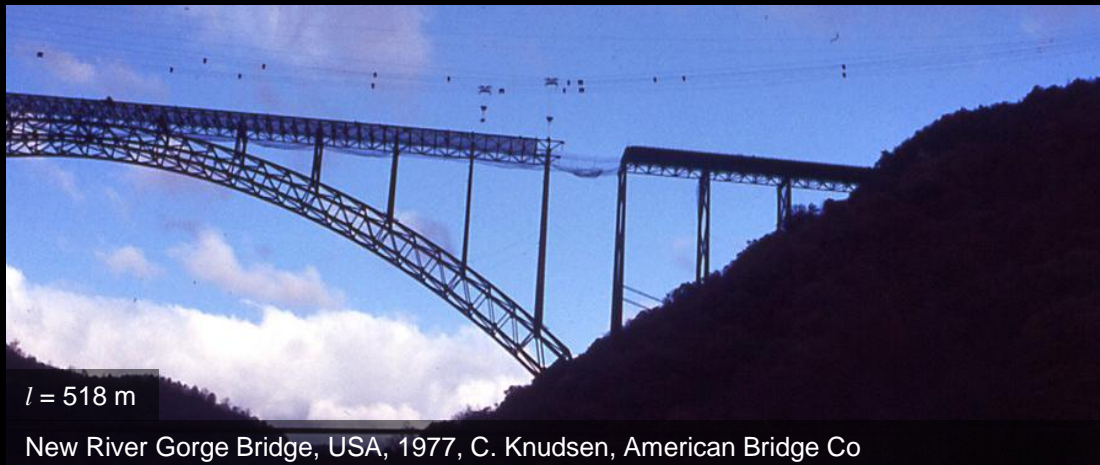

Arch bridges – Erection methods: **Cantilever-constructed steel arches**

- Steel truss arches are still being built today, see e.g. the bridge illustrated on this slide (New Burro Creek Bridge, 2007), cantilevered using temporary diagonals similar as in recent concrete arches, see behind).
- However, mainly due to the relatively high cost of steel as a compression member, they have become **less competitive** compared to other typologies:
 - **Cable-stayed bridges** are more economical than tied or through arches in most cases, particularly for very large spans
 - **Concrete arch bridges** have become more economical for medium-large spans by the development of erection methods that are much more efficient than centrings
 - Recently, **steel-concrete arch bridges** have become economical for even longer spans and are frequently used, particularly in China

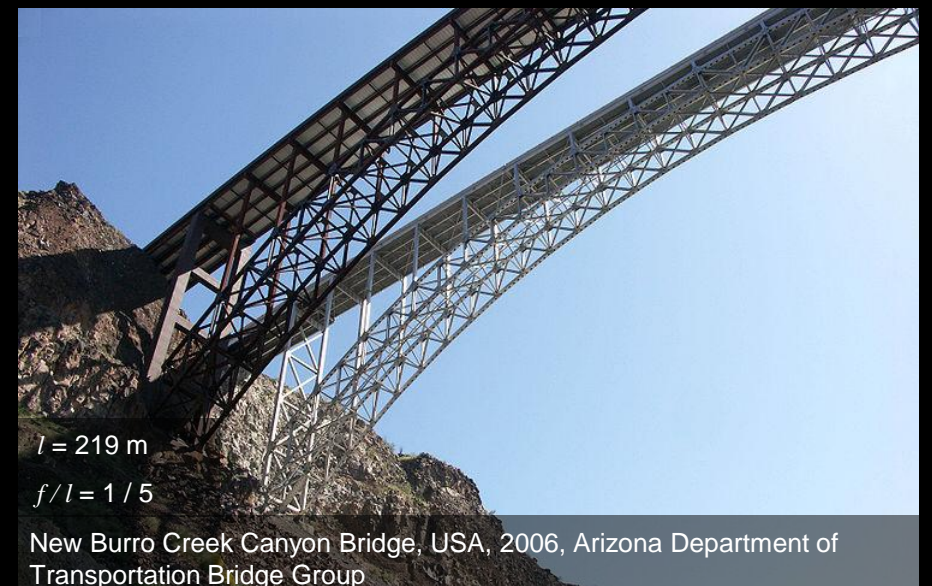

Arch bridges

Erection methods – **The Melan System and related methods**

Arch bridges – Erection methods: **The Melan System and related methods**

- The erection of efficient arch bridges can be greatly facilitated by the **combined use of steel and concrete**.
- Already in 1892, **Josef Melan** patented his **Melan System**, which used steel profiles as “rigid reinforcement” – essentially a **composite construction system** (see notes). Applying this system to arch bridges consists of the following:
 - **erecting a steel arch** (steel truss, bracings provided to ensure stability against buckling)
 - **fixing a (timber) formwork to the steel arch**
 - **casting the concrete** around the steel profiles
- Melan himself did not design many structures, and many engineers at the time had **concerns about the combined action of steel profiles and concrete**. Composite action was not well understood, and shear connectors unknown.
- **Heinrich Spangenberg** resolved the concerns regarding different stress states in steel and concrete by ballasting the steel arch with gravel and removing the latter in the sections where the concrete was cast (System **Melan-Spangenberg**).
- The **Echelsbacher Brücke** (illustrations) was the longest span arch built using this system.



Arch bridges – Erection methods: **The Melan System and related methods**

- However, the **Melan-Spangenberg** system complicated erection and **undermined the economical advantages of the Melan System**
 - many, if not most “Melan arch bridges” were **built using conventional falsework**
 - Often, Melan System trusses were supported **on towers / shoring**, see photos of **Pont des Planches**

Echelsbacher Brücke: Steel truss

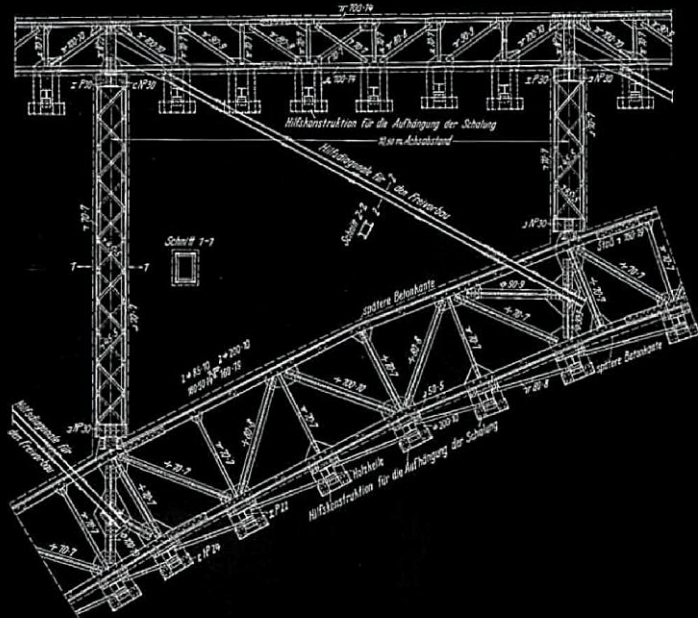

Echelsbacher Brücke: Arch section and formwork

yellow: steel truss / blue: gravel

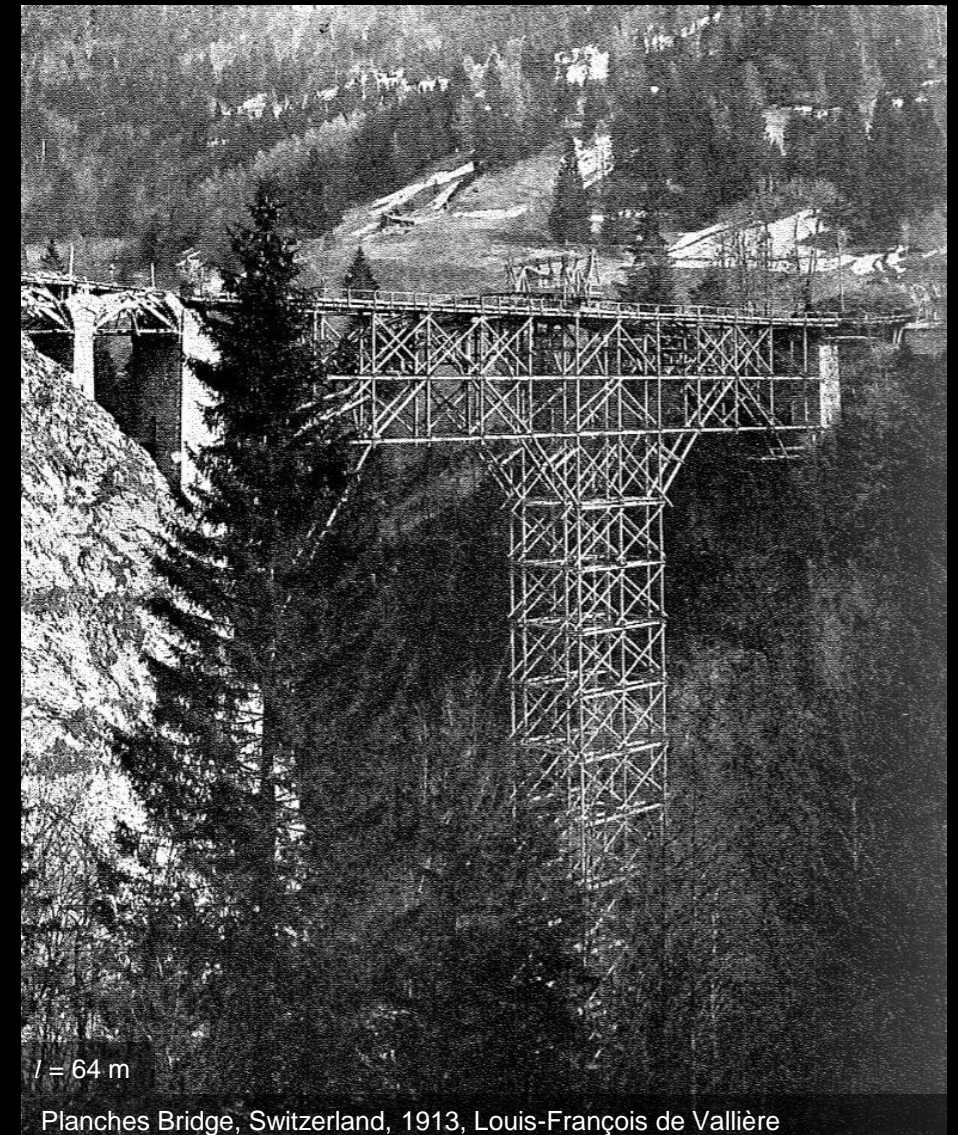
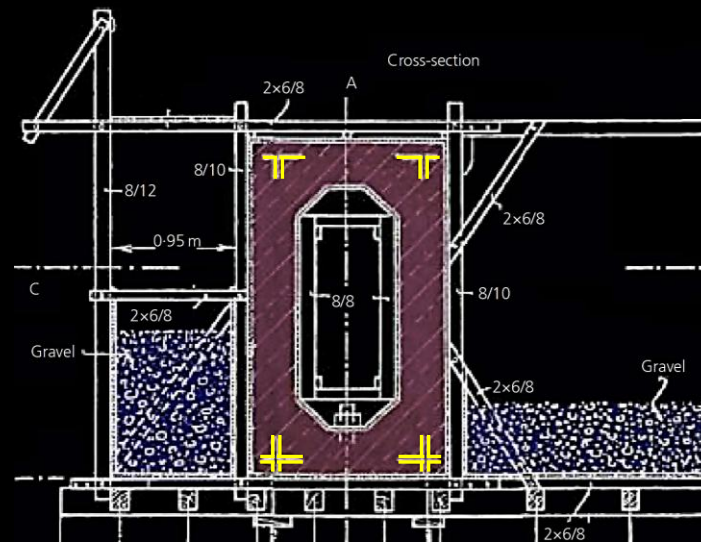

Arch bridges – Erection methods: **The Melan System and related methods**

- The Spanish engineer and entrepreneur **José Eugenio Ribera** optimised the Melan System (double trusses providing more stiffness) and patented the modified system himself in 1902.
- Ribera was very successful with this system in Spain, building several hundred bridges his patent.
- **Fritz von Emperger**, a scholar of Melan, was similarly successive with the original Melan System in the U.S. (Melan Arch. Constr. Company).
- The Melan-Ribera System was **refined to perfection by Eduardo Torroja** in the Viaducto Martín Gil (Río Esla, embalse de Ricobayo), by **subdividing the concrete section in several parts**, successively increasing the strength and adding more weight. This way, the arch with 210 m span could be built using a **surprisingly light steel truss** (less than 500 kg/m, according to L.M. Viartola, for the 4.5 m deep concrete arch, see notes).

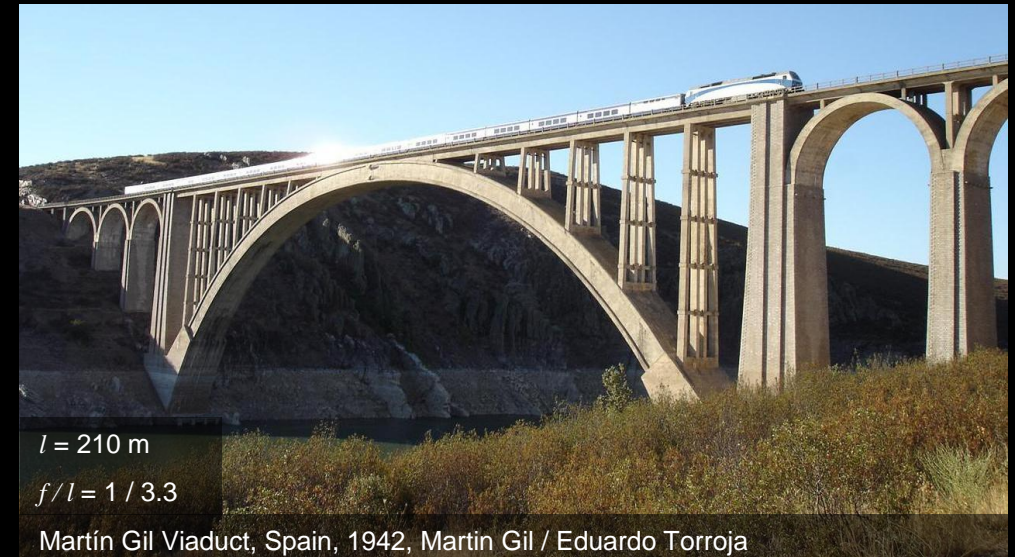

Arch section
(casting
sequence)

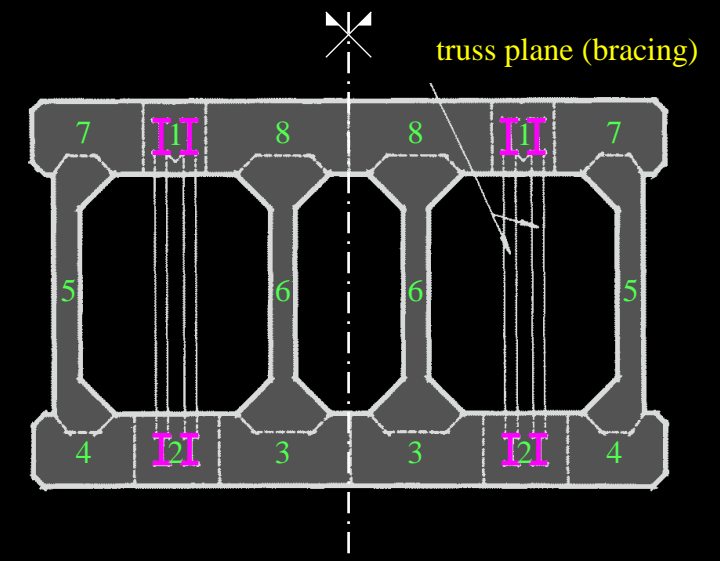

Arch bridges – Erection methods: **The Melan System and related methods**

- By subdividing the cross-section in several stages, both in cross-section as well as along the arch axis, **bending moments during erection** and **buckling risk** could be minimised.
- While this was economical at the time, such a refined subdivision of the section would be excessively expensive today (high labour cost)

Half arch section with reinforcement

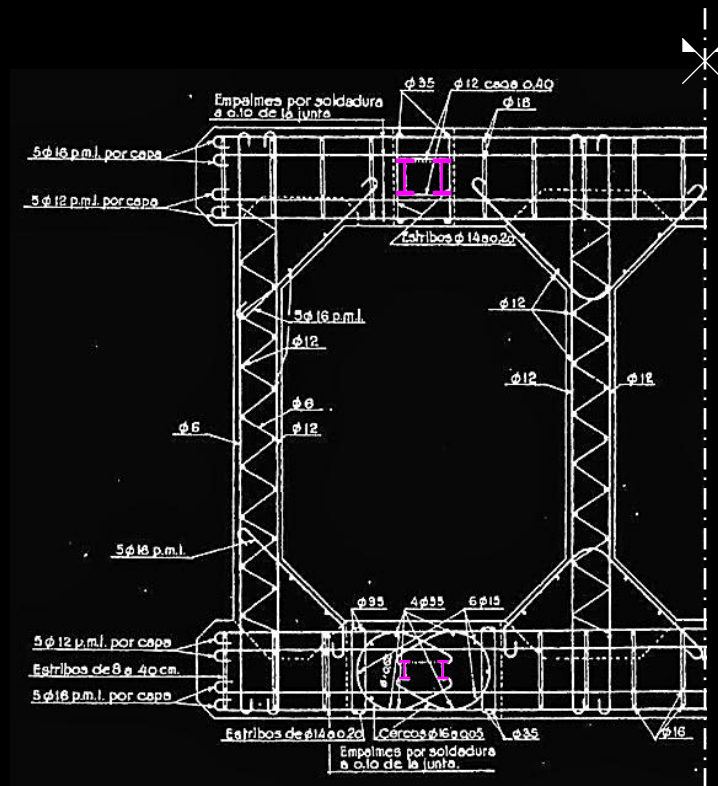

Arch bridges – Erection methods: **The Melan System and related methods**

- In spite of the success of Ribera and Emperger, designers like Maillart **did thus not use these systems**, partly due to the mentioned concerns about the bond between steel and concrete (in fact, delamination has been observed in some early Melan arches), partly due to other reasons (rivalry, nationalism, ...).
- During and after World War II, due to the scarcity of steel, **the building systems with rigid reinforcement** (Melan, Ribera, and others) **disappeared**.
- For example, the elegant arches of Ch. Menn (Tamina, Nanine Casciella) were **built on timber falsework, just like arches centuries earlier**.
- Due to the increasing Labour cost, this was already very costly at the time, and would be excessively expensive today.



$l = 100 \text{ m}$

$f/l = 1 / 4.8$

Rhein bridge, Switzerland, 1962, Christian Menn

Arch bridges – Erection methods: **The Melan System and related methods**

- Actually, it appears that the Melan System, and its potential economical benefits, had **faded into oblivion** (or it was still regarded as inferior due to the concerns about steel-concrete connection).
- For example, in his **seminal book *Prestressed Concrete Bridges, Ch. Menn*** – doubtlessly a leading arch bridge designer of his time – briefly mentioned the Melan system and Emperger's applications to arches in the historical overview, but
 - throughout the entire section of arch bridges **implicitly presumed casting on centring**
 - merely referred to different ways of casting the arch to minimise the load to be carried by the centring
- In slender slab arches, which are very elegant in the final configuration (and therefore preferred by Ch. Menn), the centring needs to carry not only the weight of the arch, but – to avoid instability – also a significant portion of the column and deck girder weights, **requiring heavy and expensive centrings**.



Arch bridges – Erection methods: **The Melan System and related methods**

- Some designers did, however, use the Melan System. This and the next slide show two examples of Swiss and Austrian applications, where the **steel trusses were assembled upright and rotated subsequently** around the arch abutments (as previously used in erecting large arch centrings, e.g. for the Pont de Longeray, 1943).
- Although the **clients and engineers** involved in the projects shown on this slide **were convinced** that the system had many advantages and anticipated a more frequent use in the future, very **few arch bridges** were built in **Europe** using the Melan System over the past decades.



Rotation of centering for the Longeray arch bridge

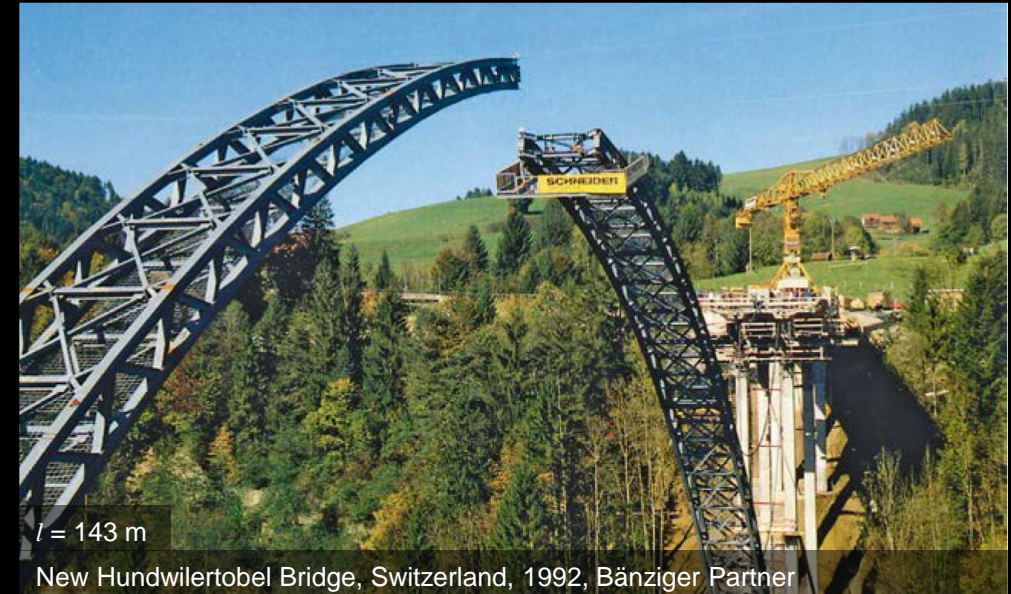

New Hundwilertobel Bridge, Switzerland, 1992, Bänziger Partner



Stampfgraben Bridge, Kärnten, Austria, 2003, P. Schallaschek.

Arch bridges – Erection methods: **The Melan System and related methods**



New Hundwilertobel Bridge, Switzerland, 1992, Bänziger Partner

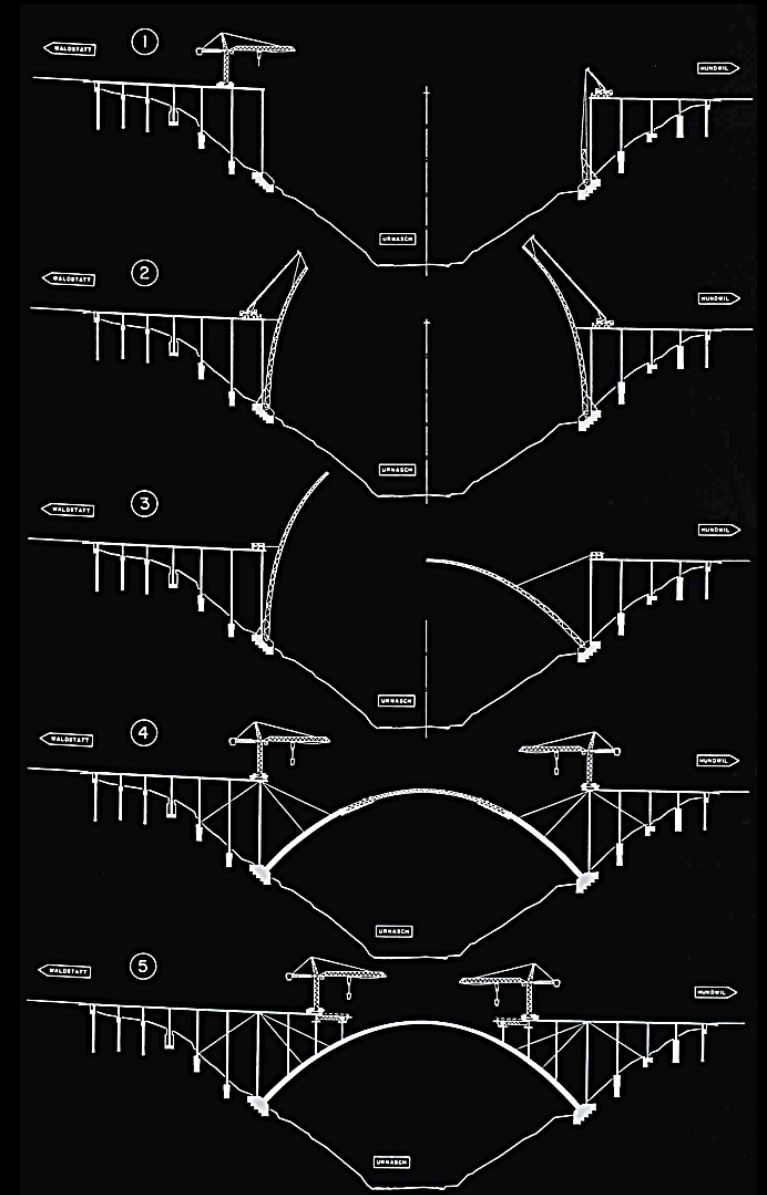

Arch bridges

Erection methods – **Vertical assembly and rotation**

Arch bridges – Erection methods: **Vertical assembly and rotation**

- The vertical assembly of arches, with subsequent rotation to closure, has also been used but for entire arch halves.
- In steel arches, tieback forces are moderate thanks to the reduced weight, as in the **Viaducto de Alconétar (2006)**.



Arch bridges – Erection methods: **Vertical assembly and rotation**

- Much higher tieback forces are required in concrete arches, due to the higher weight.
- Nonetheless, Riccardo Morandi used this method already in the 1950s, first in a footbridge (Vagli Sotto, Garfagnana) and then in the **Paul Sauer Bridge over the Storms River, South Africa (1956, span 120 m, rotated arch halves 37 m each)**.

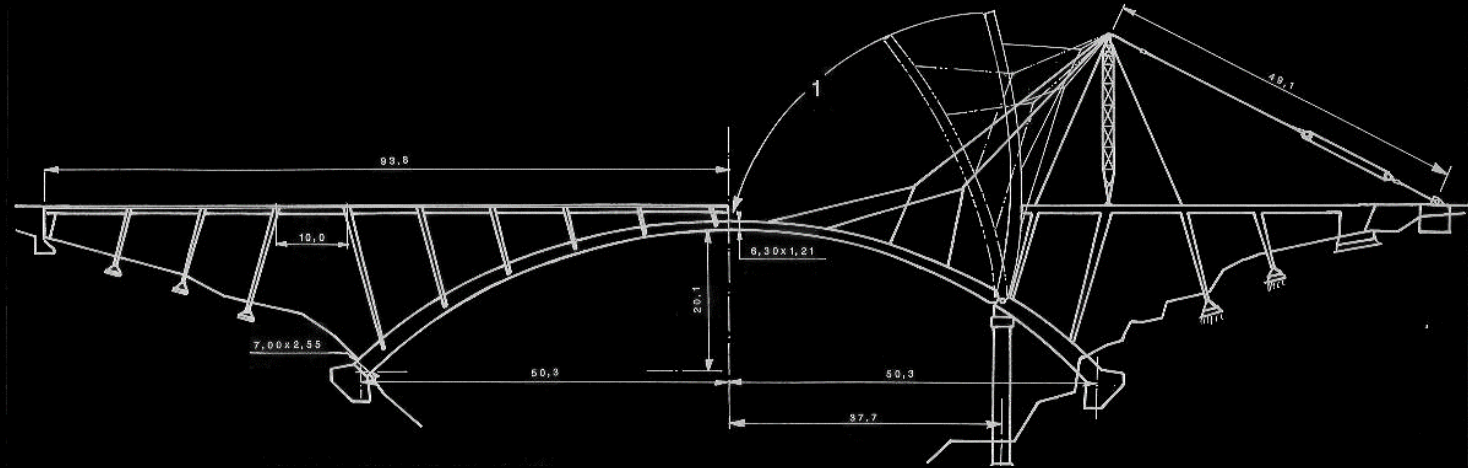

Arch bridges

Erection methods – **Cantilever-constructed concrete arches**

Arch bridges – Erection methods: Cantilever-constructed concrete arches

- Rather than Melan System arches, the following construction methods have been frequently used for medium-large span concrete arches in Europe in the last decades
 - cantilevering using temporary stays and, in longer spans, towers (“stayed arch cantilevering”)
 - cantilevering of deck and arch as a truss, with temporary diagonals (“deck-and-arch truss cantilevering”, sometimes using temporary cables running parallel to the deck and temporary spandrel columns)
- In the following, deck and arch truss cantilevering is described first. Stayed arch cantilevering was used earlier and is more frequently used today. It is also used in the modern CFST method, and therefore outlined afterwards.
- The first large-span deck-and-arch truss cantilevered concrete arches known to the authors are the Krk bridges (spans of 244 and 390 m), designed by Ilija Stojadinović.
- The longer of the two bridges was the record span for concrete arch bridges until 1997; accounting for the underwater part, it would have held this record even longer.

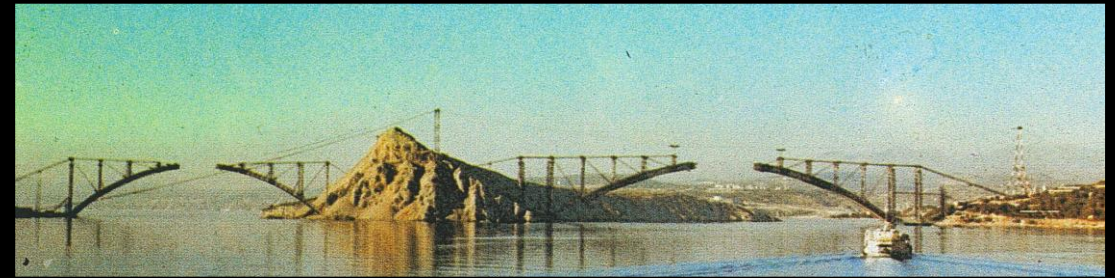

Arch bridges – Erection methods: **Cantilever-constructed concrete arches**

- In the Krk bridges, **temporary cables running parallel to the deck** were used, rather than activating the deck in tension, and **temporary spandrel columns** were also used during cantilevering
- The arch was built in stages, connecting the precast elements by in-situ joint casting:

arch cantilevering (temporary cables, diagonals + columns)



midspan closure (jacks regulating arch thrust = geometry installed until 1985)

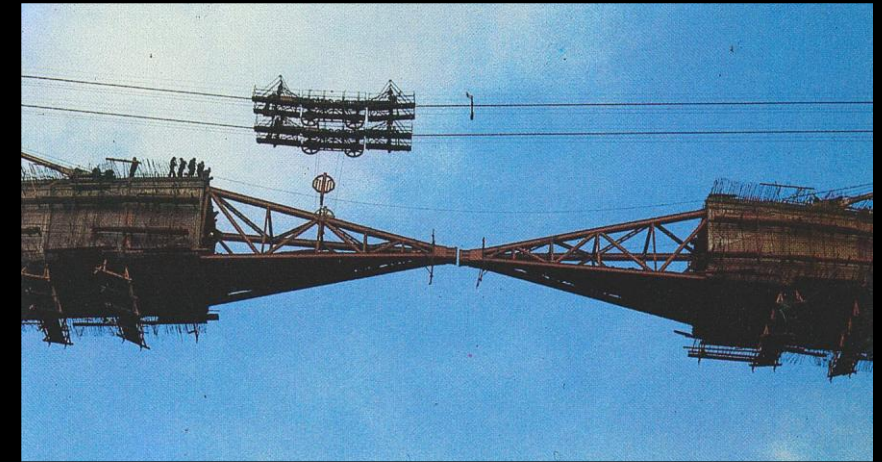

Arch basic section (cantilevered)

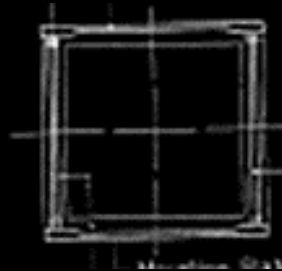

Arch final section (outer ribs added after arch closure)

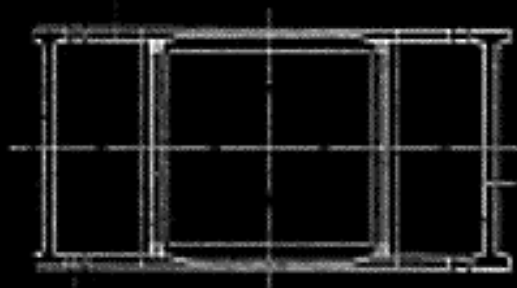

assembly of arch basic section (cantilevered part)

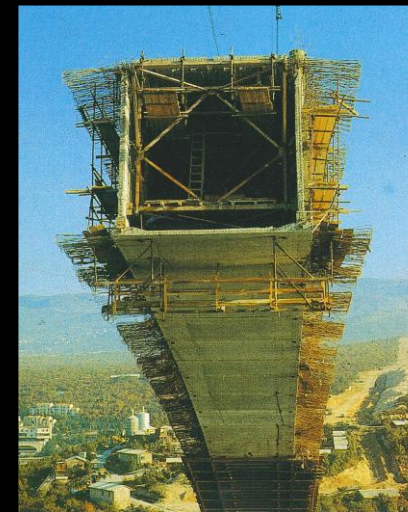
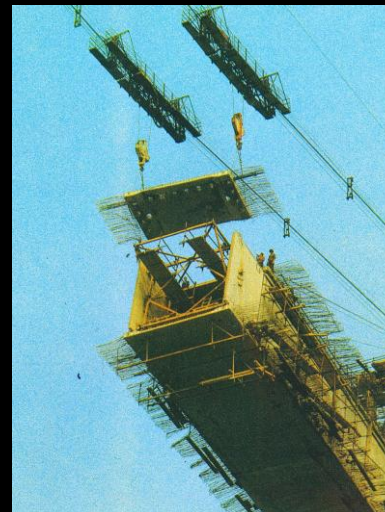

hoisting of outer arch ribs

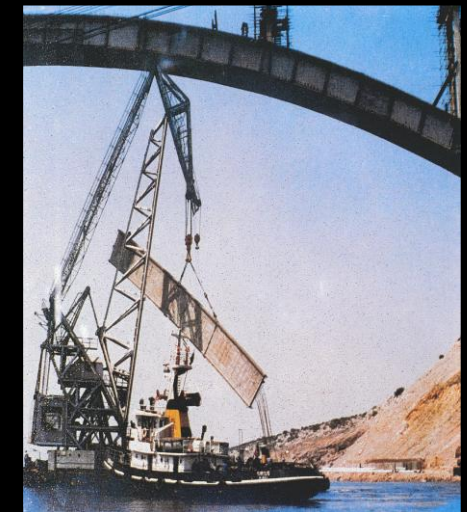

Arch bridges – Erection methods: **Cantilever-constructed concrete arches**

- In the Krk bridges, **temporary cables running parallel to the deck** were used, rather than activating the deck in tension, and **temporary spandrel columns** were also used during cantilevering
- Precast elements were also used for the deck girder, resulting in a very efficient erection



spandrel column



spandrel column with temporary diagonal



deck erection (precast girders)

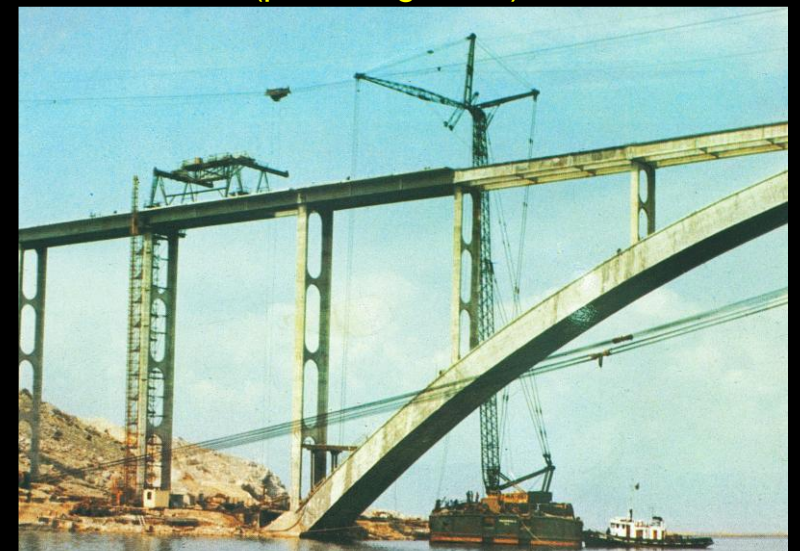

Arch bridges – Erection methods: Cantilever-constructed concrete arches

- The Arco de la Regenta (Puente Pintor Fierros) was also built using deck-and-arch cantilevering, in this case using the steel-concrete composite deck as tension chord.
- This bridge was opened in 1996 and widened from two to four lanes (12 → 22 m width) in 2008, under traffic, without substantial strengthening need on arch nor foundations: These had already been designed in 1996 to enable a later widening.



$l = 194 \text{ m}$

$f/l = 1 / 3.8$

Regenta Arch Bridge, Spain, 1996, Asturias. J.J. Arenas

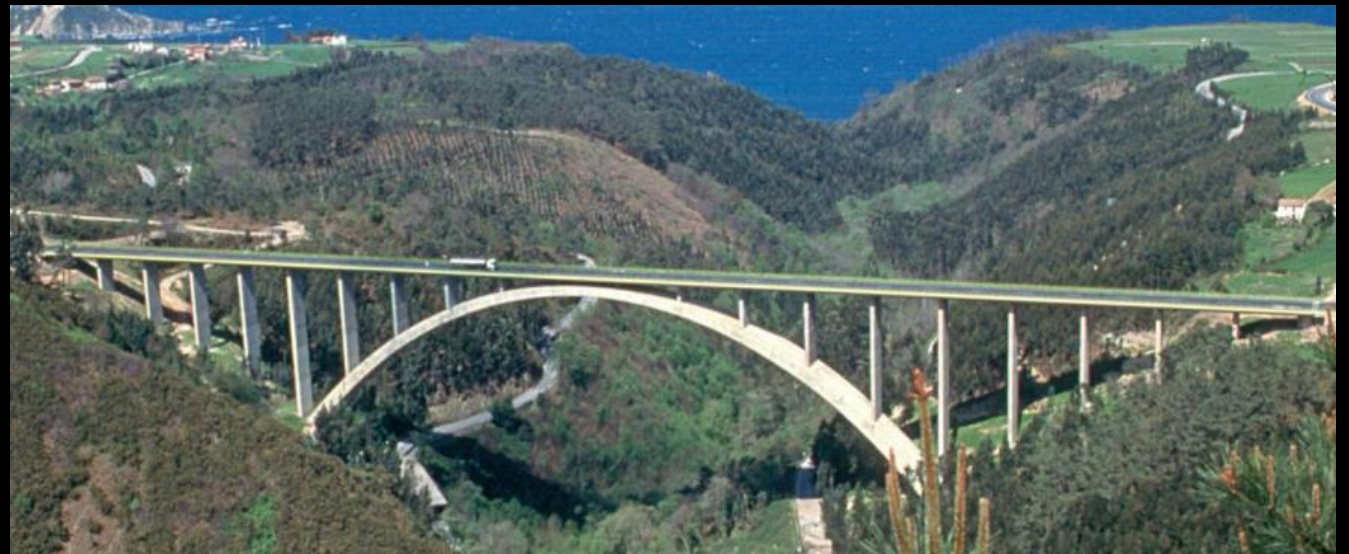

Arch bridges – Erection methods: **Cantilever-constructed concrete arches**

- The **Arco de los Tilos** is one of the longest span concrete arches built in the past decades by deck-and-arch truss cantilevering.
- As in the Arco de la Regenta, the **steel-concrete composite deck was used as tension chord**.



$l = 255 \text{ m}$

$f/l = 1 / 5.5$

Tilos Bridge, Spain, 2004. S. Pérez-Fadón Martínez and J.E. Herrero Benítez





Arch bridges – Erection methods: **Cantilever-constructed concrete arches**

- **Stayed arch cantilevering** was used earlier than deck-and-arch cantilevering and is more frequently used today. It is also used in the modern CFST method described at the end of this chapter.
- While stayed arch cantilevering had been used in steel bridges much earlier, the first known application of **stayed concrete arch cantilevering** are the three arch viaducts of the Caracas-La Guaira motorway in Venezuela, designed by E. Freyssinet / J. Muller and built by Campenon Bernard.
- Rather than cantilevering the entire arch, the **middle part was built on an 80 m long falsework** suspended from the arch cantilevers. This has the advantage that flat, inefficient stays can be avoided without the need for towers.

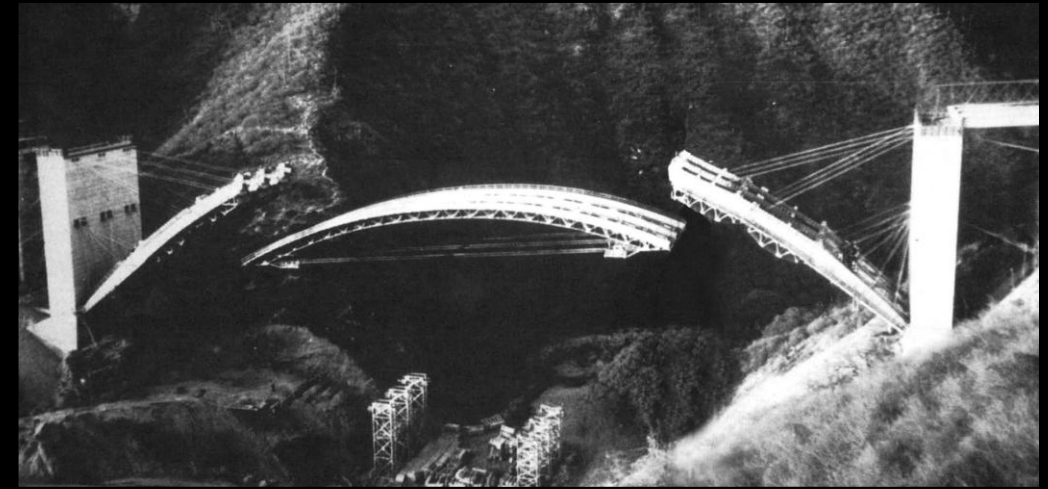

$l = 152 \text{ m}$

La Guaira Viaduct, Venezuela, 1952/1953, E. Freyssinet / Jean Muller

Arch bridges – Erection methods: Cantilever-constructed concrete arches

- A similar erection method as in the Caracas-La Guaira arches was used for the outer parts of the falsework of the **Ponte da Arrábida** (span 270 m), see photos on right side .
- Today, stayed cantilevering of the entire arch is more frequent, see bottom photo (**Ponte Val Crotta** in Ticino, span 90 m).
- Commonly, the arch is cast in situ, using **formwork travellers** similar to those used for cantilever-constructed concrete girders
- Alternatively, **precast segmental cantilevering** is also used.



Arch bridges – Erection methods: **Cantilever-constructed concrete arches**

- In the **deck-and-arch truss cantilevering** method, **high tieback forces are required**, limiting the field of application in terms of span and soil conditions for anchorage of temporary backstays.
- In **stayed arch cantilevering**, equally high stayback tie forces result if no towers are used. The tieback forces can be substantially reduced by using **temporary towers**, similar as used when cantilevering large span steel truss arches
- If temporary towers are used in stayed arch cantilevering is an economical decision: The **extra cost for the towers** needs to be compensated by the **reduced stay forces and backstay anchorage** cost. Usually, towers are economical for large span arches.
- The slide shows different choices for tower heights adopted in two arch bridges designed by **Ilija Stojadinovic**: The **Šibenik arch bridge** (span 246 m, high towers) and the **Pag arch bridge** (span 193 m, low towers).

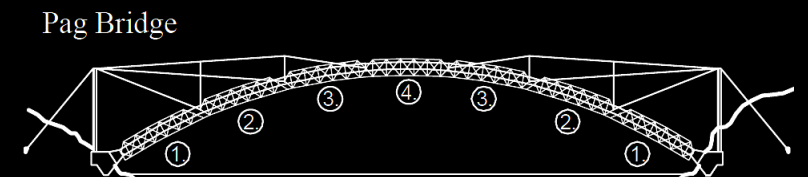
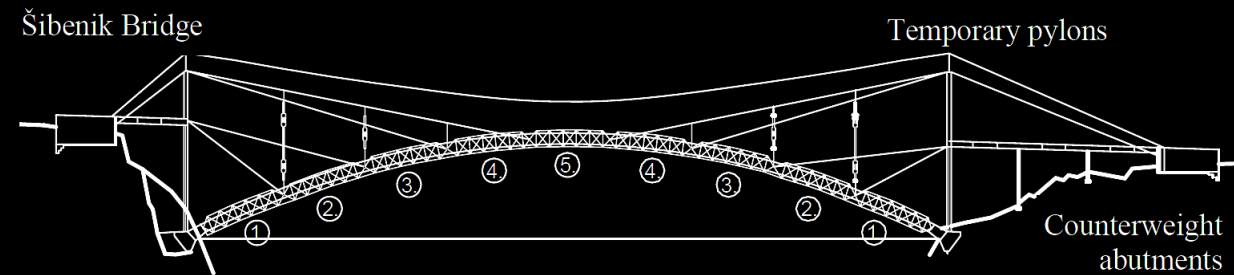

Arch bridges – Erection methods: **Cantilever-constructed concrete arches**

- The **Viaducto de Almonte**, whose arch was built cantilevered using towers and stays, is one of the world's longest – and most elegant – concrete arches, and the longest span high speed train arch bridge worldwide.
- More details, see presentation of **guest speaker Guillermo Capellán**.

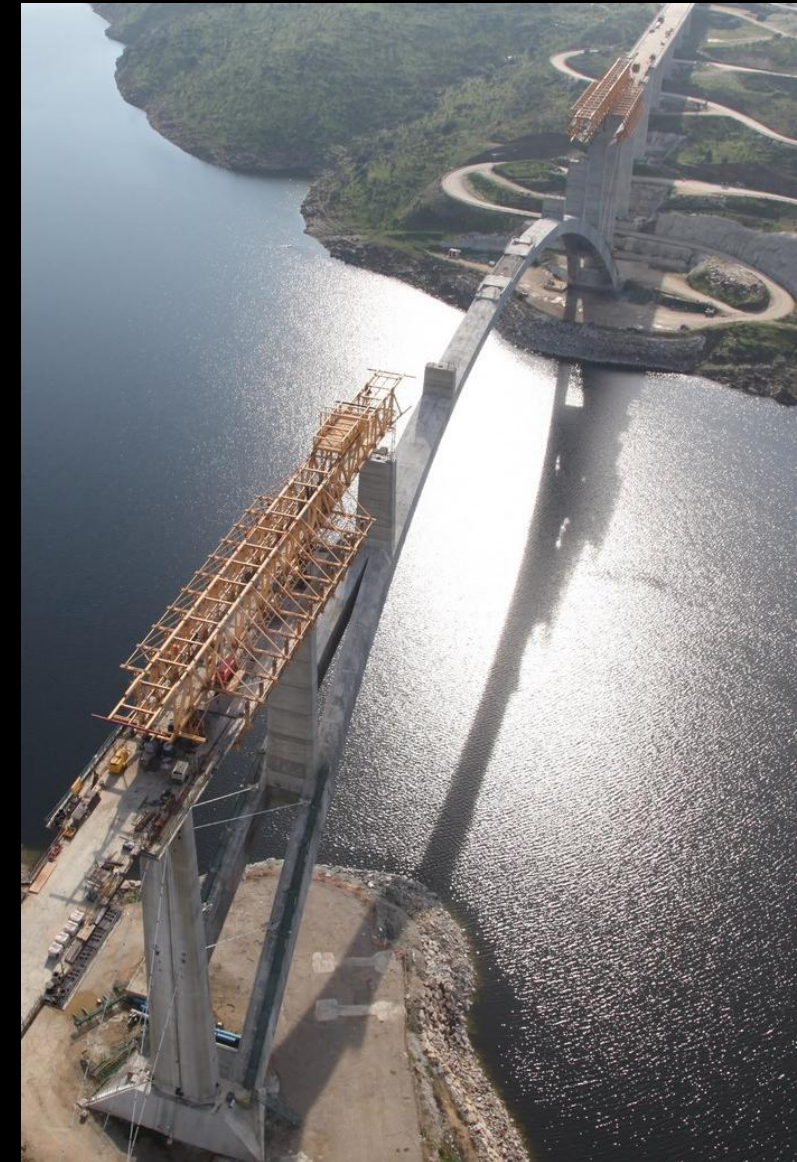



Arch bridges – Erection methods: **Cantilever-constructed concrete arches**

- The Tamina Bridge is another recent example of a large span concrete arch cantilevered using towers and stays



$l = 260 \text{ m}$
 $f/l = 1/7.4$

Tamina Bridge, Switzerland, 2017, Leonhardt, Andrä und Partner



Arch bridges – Erection methods: Cantilever-constructed concrete arches

0. **Final stage of half arch:** Half arch modelled with hinges at all intersection points (arch-ties) except in the last tie close to the crown. This arrangement gives the tension forces $T_{i,0}$ of the ties in the last construction phase. Cable preload is chosen such that the correct arch geometry is obtained.

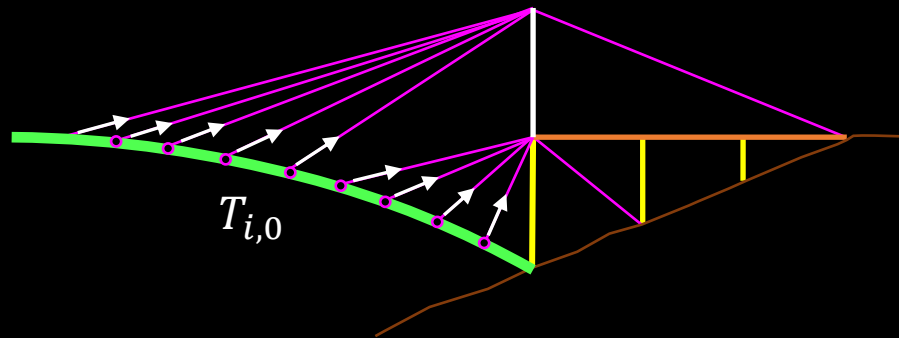

1. **Disassembling the structure from the final stage of the half arch:** Half arch without hinges. The last segment is removed and its self-weight is applied to the remaining structure with opposite sign.

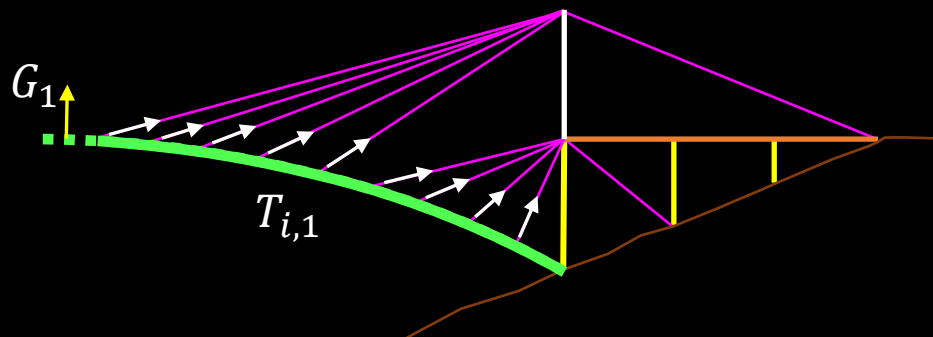

2. **Disassembling the structure from the previous step:** Half arch without last segment, without hinges. The last stay cable is removed and the tension forces $T_{1,1}$ and $T'_{1,1}$ (cable forces in corresponding cables after applying the negative self-weight G_1 in stage 1) are applied to the structure with opposite sign.

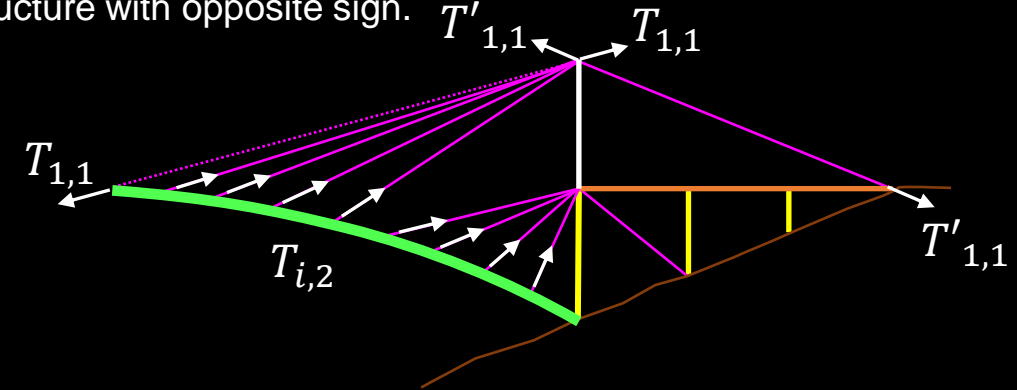

...n. **Disassembling the structure from an intermediate stage of the half arch:** Gradually shorter part of half arch without hinges. The same procedure (steps 1-2) is used to obtain the forces in each stage until the half arch is completely disassembled.

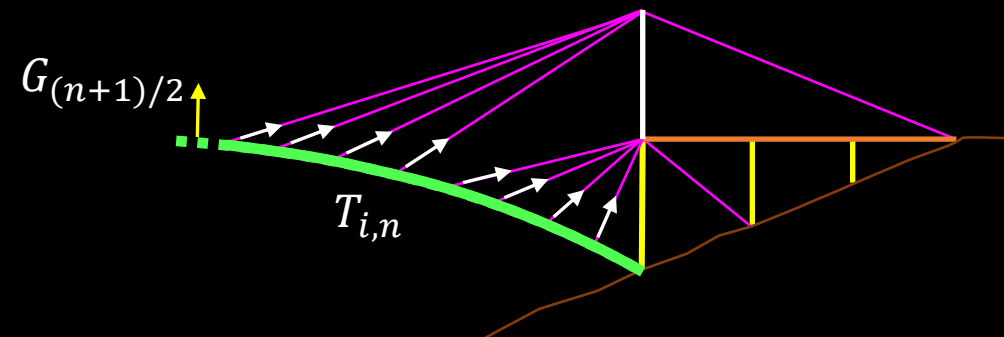



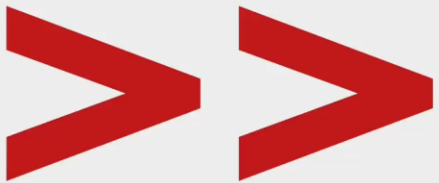

Tamina bridge: erection

Arch bridges

Erection methods – Evolution of the Melan System

Arch bridges – Erection methods: Evolution of the Melan System

- In **Asia**, arch erection methods inspired by the Melan System have been much more successful over the past decades.
- In **Japan**, more than 20 arch bridges have been built since 1970 using partial **Melan System** solutions (according to Eggemann and Kurrer, see notes and photos on this slide: **Kashirajima Bridge**, span 218 m).
 - erecting parts near abutments conventionally by arch cantilevering (stayed or trussed)
 - lifting in steel girders for the Melan System midspan part
- In **Japan** and particularly in **China**, many long span arch bridges have been, and are being erected using hollow steel profiles, filled with concrete after closure. The steel profiles thus serve as combined falsework and reinforcement.
- This method, evidently similar to the Melan System (though only recognised by the Japanese), is known as “concrete lapping with pre-erected composite” (**CLCA**) in Japan, and as “Concrete filled steel tube arches” (**CFST**) in China.
- The CFST Method is described on the following slides.



Arch bridges – Erection methods: Evolution of the Melan System

- In **CFST arch bridges**, hollow section steel arches are erected by **stayed cantilevering** and subsequently **grouted with concrete**, forming a steel-concrete composite arch.
- In China, **more than 400 CFST arch bridges** have been built (≥ 12 with $L > 300$ m, ≥ 4 with $L > 400$ m). This slide shows a recent example (Xiangxi Yangtze River Bridge, span 508 m (2019)).



Arch bridges – Erection methods: Evolution of the Melan System

- Currently, the maximum span of a CFST arch bridge is 530 m (First Hejiang Yangtze River Bridge, aka Bosideng Bridge, 2013, see photos).
- Much research has been carried out in China to optimise this type of structures, e.g.
 - ... adjusting stay forces during grouting to minimise bending moments
 - ... grout properties and vacuum grouting etc.
 - ... composite action of tubes and concrete
 - ... etc.

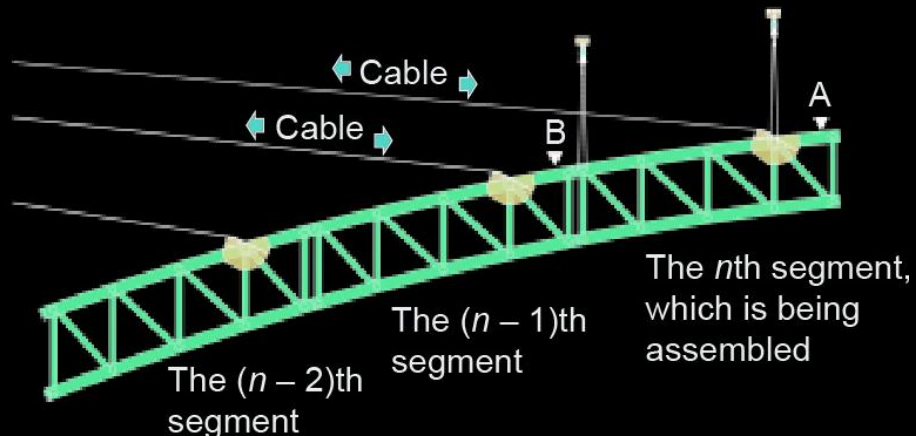



万里长江·大橋行

新長江

万里长江·大橋行

万里长江·大橋行

Arch bridges – Erection methods: Evolution of the Melan System

- A further development of CFST bridges consists in arches made of a **CFST composite steel skeleton encased by concrete** – even closer to the concept of the original Melan System – are being built, mainly also in China (“**CFST reinforced concrete arches**”).
- A recent example is the **Yunnan–Guangxi Railway Nanpan River Bridge** (aka **Nanpanjiang Railway Bridge Qiubei**, see photos).



$l = 416 \text{ m}$
 $f/l = 1 / 4.2$

Yunnan–Guangxi Railway Nanpan River Bridge, China, 2016



Arch bridges – Erection methods: Evolution of the Melan System

- The similarity of the cross-section of the **Yunnan–Guangxi Railway Nanpan River Bridge** to Torroja’s solution for the Viaducto Martín Gil is striking– albeit at a much larger scale (figures on right side):
 - **Viaducto Martín Gil:**
Span 192 m, $f/L = 1/3.3$, $h_{arch} = 4.5$ m
 - **Nanpan River Bridge:**
Span 416 m, $f/L = 1/4.2$, $h_{arch} \approx 9$ m (steel tubes = 8 m)
- **CFST reinforced concrete arches** have clear advantages in terms of durability and maintenance (no coating)
- Furthermore, they are very efficient and economical:
 - **high contribution of inexpensive concrete**
 - avoidance of buckling issues by **gradually increasing inertia and load** carried by the arch
 - minimisation of bending moments during casting by **optimising casting sequence along arch span**, and **actively controlling stay forces**
- **Spans up to 700...800 m** appear economically feasible in China according to Zheng and Wang (source see note).

Yunnan–Guangxi Railway Nanpan River Bridge:
Cross-section and casting sequence (size steel tubes approximate)

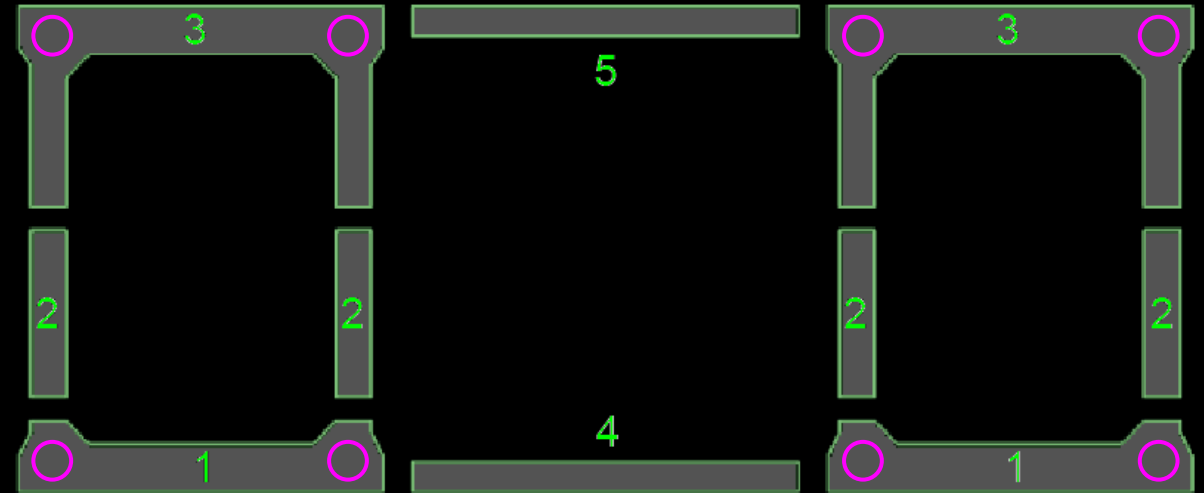

Comparison with Viaducto Martín Gil:
Cross-section and casting sequence
(\approx same scale as above)

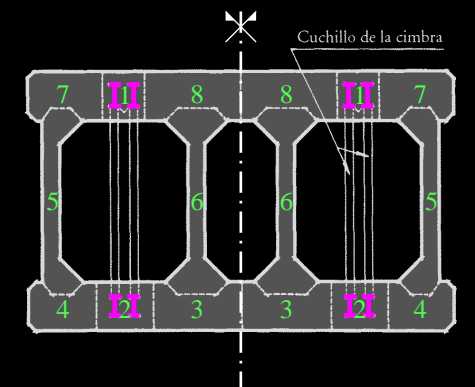





Arch bridges

Erection methods – **Final remarks**

Arch bridges – Erection methods: **Final remarks**

- In many arch bridges, the **deflection caused by the axial deformation of the arch** – causing significant bending moments, see structural behaviour – is **compensated at closure by applying a controlled axial force** at the crown by means of hydraulic jacks.
- Throughout the history of arch bridges, there has been a debate whether such an “opening of the crown” is useful or even required, as there are **pros** and **cons**:
 - **helps actively controlling the geometry**
 - **helps removing the formwork and falsework in concrete arches** (if the jacking force corresponds to the arch thrust under dead load, the arch lifts off the formwork)
 - **in tied arches, it may eliminate the need for hanger re-tensioning**
 - **causes extra cost and complicates the erection process**
 - **in concrete arches, most of the effect is lost due to creep**
- Essentially, whether such an operation is carried out **is a decision of the designer**. In any case, the design has to consider the corresponding internal actions.

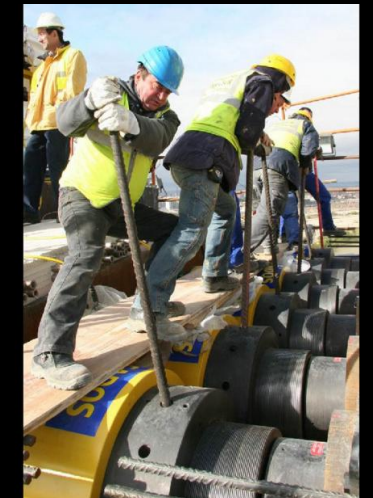

Arch bridges – Erection methods: **Final remarks**

- Short span steel arch bridges are **usually lifted in**, where possible with temporary shoring.
- The slides show two examples, with and without shoring.

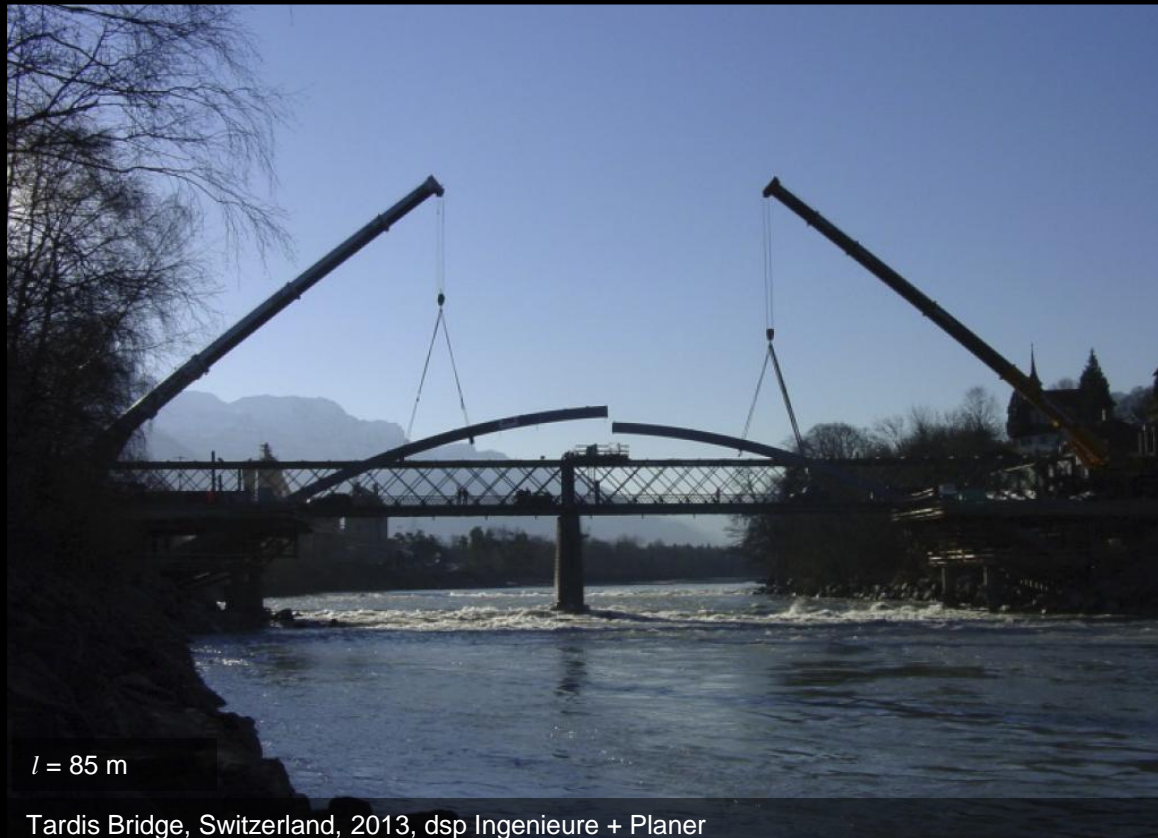

$l = 85 \text{ m}$

Tardis Bridge, Switzerland, 2013, dsp Ingenieure + Planer



$l = 60 \text{ m}$

$f/l = 1/8$

Pontones Bridge, Spain, 2005, Arenas & Asociados

Arch bridges – Erection methods: **Final remarks**

- **Tied arch bridges**, being “externally” **simply supported**, can be launched longitudinally or transversally like girder bridges.
- The **Brücke Bernstrasse (Fürst Laffranchi / IUB)** in Oftringen was first **launched longitudinally** over the SBB tracks, subsequently carrying the traffic in this position while the old bridge was demolished. Finally, it was **launched transversely** into its final position.

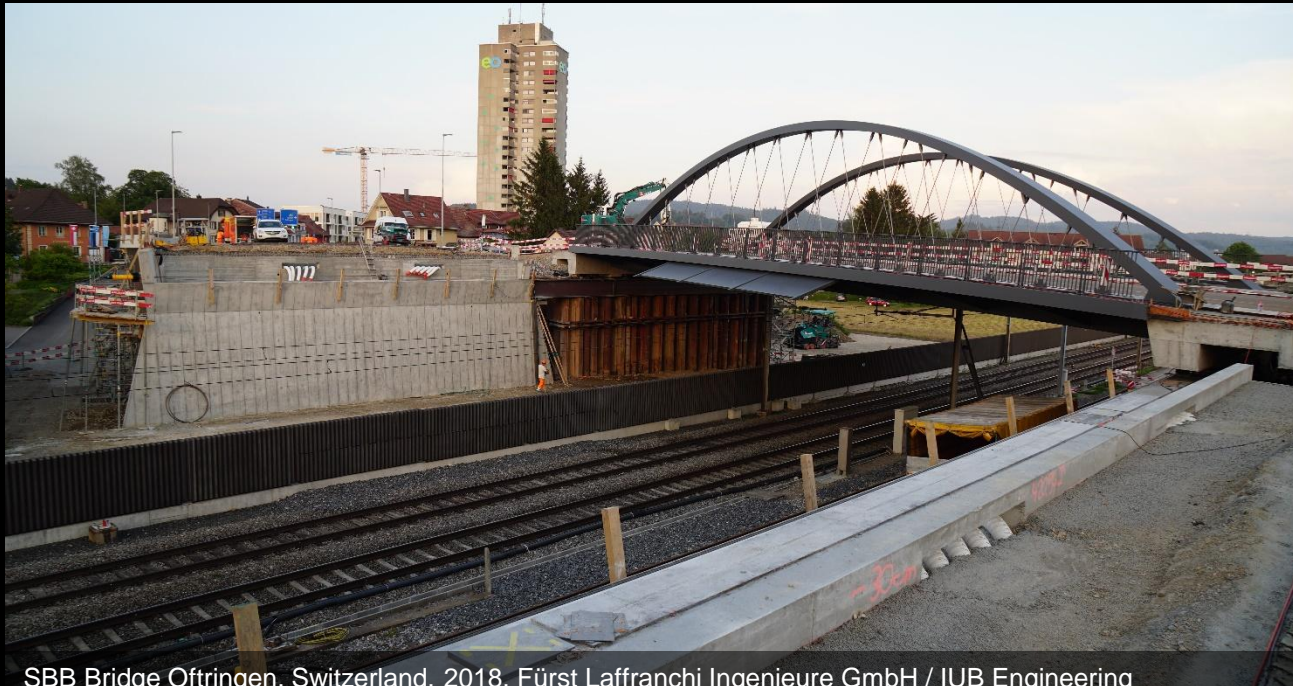

SBB Bridge Oftringen, Switzerland, 2018, Fürst Laffranchi Ingenieure GmbH / IUB Engineering



Arch bridges – Erection methods: **Final remarks**

- **Tied arch bridges crossing water** can be **built on shore**, using conventional construction methods (shoring, access for cranes, ...) and **floated into their final position** (similar to the Plougastel and Sandö bridge falsework commented earlier).
- The **Barqueta Bridge** in Sevilla was built on one riverbank and rotated 90° in plan across the river Guadalquivir into its final position.



$l = 168 \text{ m}$
 $f/l = 1/6$

Barqueta Bridge, Spain, 1992, J.J. Arenas and M. Pantaleón

