

Superstructure / Girder bridges

Design and erection

Steel and steel-concrete composite girders

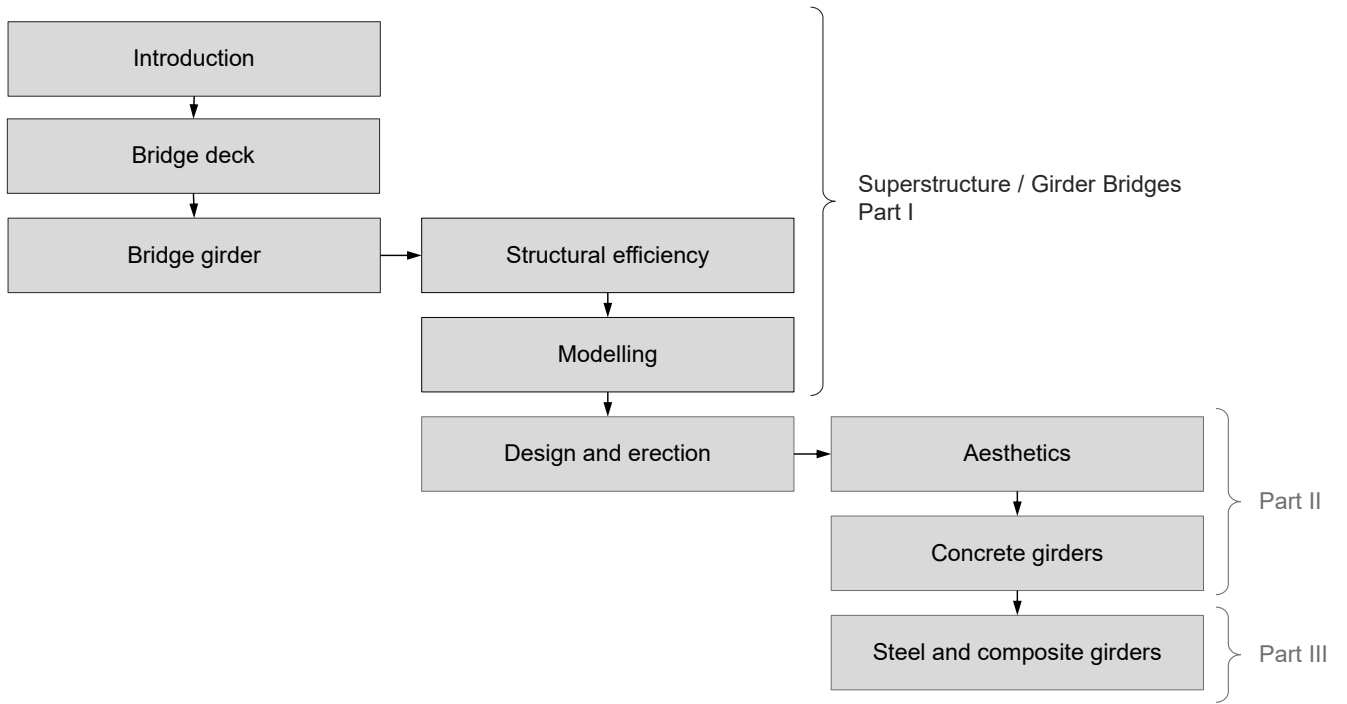

Steel and composite girders

Advantages and disadvantages
(compared to prestressed concrete bridges)

Steel-concrete composite bridges are usually more expensive. However, they are often competitive due to other reasons / advantages, particularly for medium span girder bridges ($l \approx 40 \dots 100$ m).

Advantages:

- reduced dead load
 - facilitate use of existing piers or foundation in bridge replacement projects
 - savings in foundation (small effect, see introduction)
- simpler and faster construction
 - minimise traffic disruptions

Disadvantages:

- higher initial cost
- higher maintenance demand (coating)
- more likely to suffer from fatigue issues (secondary elements and details are often more critical than main structural components)



Photo: Ulla viaduct, Spain © IDEAM

Superstructure / Girder bridges

Design and erection

Steel and steel-concrete composite girders

Typical cross-sections and details

Steel and composite girders – Typical cross-sections and details

Open cross-sections

- Twin girders (plate girders)
 - concrete deck $\Rightarrow l \leq \text{ca. } 125 \text{ m}$
 - orthotropic deck $\Rightarrow l > \text{ca. } 125 \text{ m}$
- Twin box girder
- Multi-girder

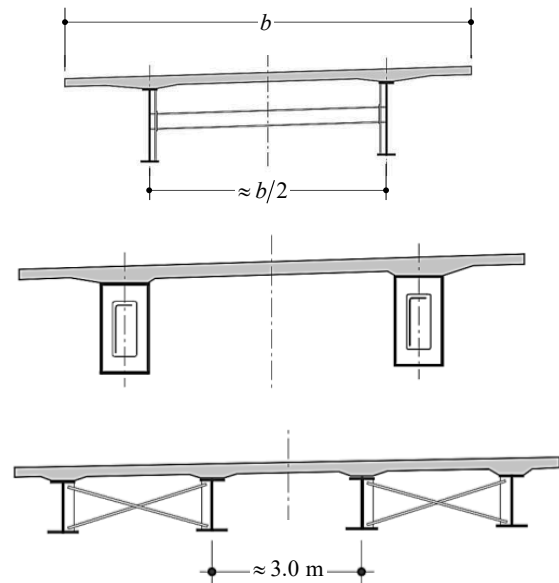

The twin plate girder solution is the simplest form of a composite bridge. The cross section comprises a concrete slab, which is structurally connected to two steel beams (plate girders). This solution is common for composite bridges with a deck width up to about 13 m (sufficient for a motorway bridge carrying two traffic lanes and an emergency lane = single carriageway).

If the slab is wider, a twin girder bridge will require a thicker concrete slab in order to resist transverse bending. This will substantially increase the weight of the slab, which will probably need to be prestressed in the transverse direction. Alternatively, a “ladder deck” may be preferable, where the deck slab transfers its load primarily in longitudinal direction to cross-beams, which at the same time act as intermediate diaphragms.

The spacing of the two main beams (except in ladder decks) usually corresponds to approximately half the deck width. While shorter cantilevers would lead to a structurally more efficient moment distribution (approximately equal positive and negative transverse bending moments), this yields a higher visual slenderness (girders are in the shadow of cantilevers). This type of cross section (or a ladder deck) is appropriate for spans up to around 125 m. For longer spans, the self-weight of the deck should be reduced by using an orthotropic steel deck. Alternatively, a box girder should be considered, since it is better suited to resist eccentric loading.

Small, narrow box sections may be used instead of I sections, in particular when headroom is limited. This type of cross-section is still classified as an open cross section even though the torsional stiffness of the boxes affects the transverse distribution of the loads (though small, the boxes have much higher torsional and lateral bending stiffnesses than the I-girders).

If the deck is very wide, or the available depth limited, a multi-girder deck may be required. For this type of cross-section, which is uncommon in Switzerland, hot rolled I-beams are often used, with transverse spacings around 3 m.

Steel and composite girders – Typical cross-sections and details

Closed cross-sections

- Steel U section closed by concrete deck slab
- Closed steel box section with concrete deck
- Closed steel box section with orthotropic deck
- Girder with “double composite action” (concrete slabs on top and bottom)
- Multi-cell box section (for cable stayed or suspension bridges)

The distinction between open and closed cross-sections is particularly relevant for the way in which the bridge resists torsion, see *spine model*.

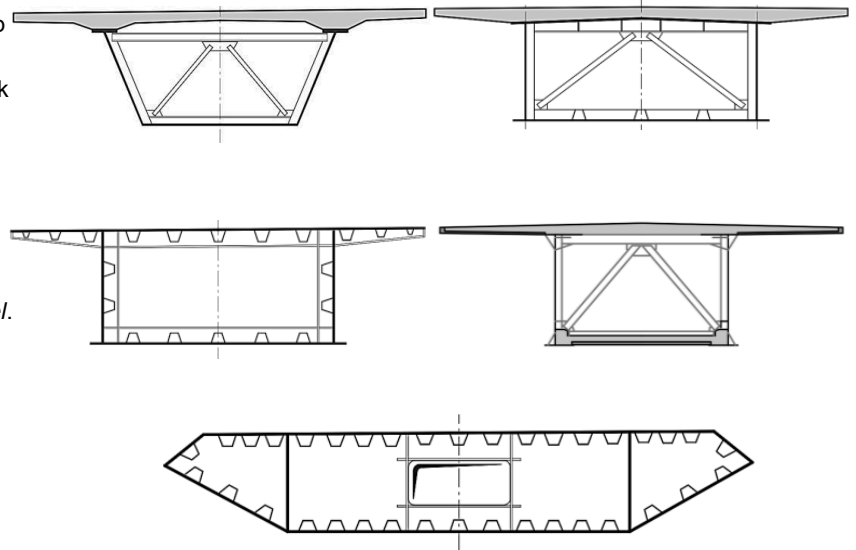

03.03.2025

ETH Zürich | Chair of Concrete Structures and Bridge Design | Bridge Design Lectures

6

Closed cross-sections of medium span composite bridges usually consist of a U-shaped steel section (“open steel box section”), onto which the concrete deck slab is connected to close the box. The box is generally of trapezoidal cross section, where the inclination of the webs relative to vertical should not exceed 20 to 25 degrees (otherwise special measures must be taken to ensure that the geometry is maintained during casting of the slab). The trapezoidal cross-section has the following advantages:

- structurally efficient deck slab support (similar positive and negative transverse bending moments)
- smaller width of bottom flange (reduces the number of longitudinal stiffeners needed to ensure the flange is fully effective in compression under negative bending moments)
- higher visual slenderness

For long spans, and depending on the erection method, a closed steel section on whose top flange the deck is cast (serving as formwork), may be advantageous. The deck slab is connected to the upper steel flange and stiffens it both longitudinally and transversally. In very long spans, the concrete slab is replaced by an orthotropic deck in order to reduce the self-weight.

The lower flange in composite box girders usually consists of a longitudinally stiffened steel plate. However, double composite action over intermediate supports (piers), where negative bending moments induce high compressive stresses in the lower flange, is becoming more and more popular to save steel and avoid stability problems.

Multi-cell box sections are common in long span cable supported bridges, where the box girder must adopt an aerodynamic form, rather than being a simple rectangle, in order to improve the aeroelastic behaviour of the bridge. Wide box girders (full deck width) are also efficient for transferring torsion with a high stiffness, which is highly relevant in cable supported structures (or even essential if only one central cable plane is provided): For aeroelastic stability, the torsional eigenfrequency should be significantly higher than the relevant eigenfrequencies in vertical bending.

Illustrations adapted from J.P. Lebet and M.A. Hirt, Steel bridges

Sources: J.P. Lebet and M.A. Hirt, Steel bridges; Reis Oliveiras, Bridge design

Steel and composite girders – Typical cross-sections and details

Truss girders



Lully viaduct, Switzerland, 1995. Dauner Ingénieurs conseils

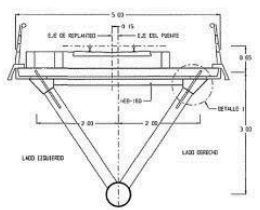
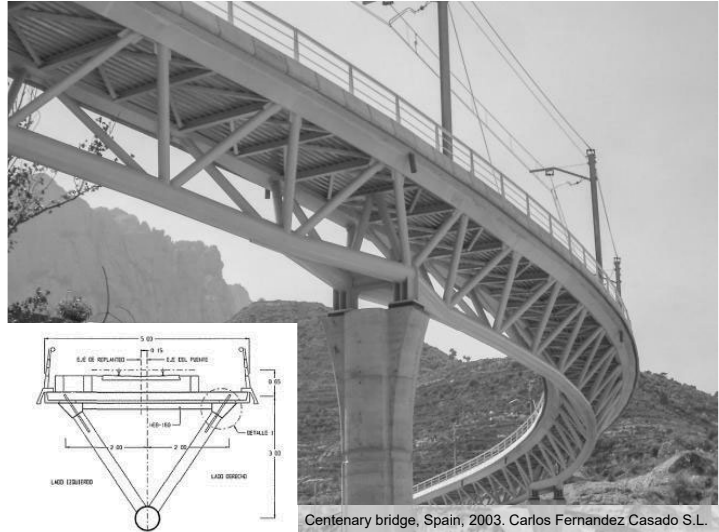
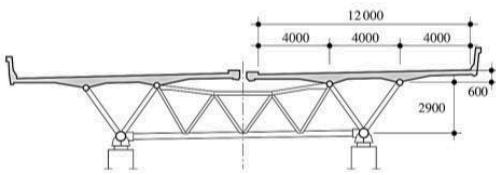

Centenary bridge, Spain, 2003. Carlos Fernandez Casado S.L.

Illustrations adapted from: left: J.P. Lebet and M.A. Hirt, Steel bridges; right: J. Manterora, Puentes I.

Photo: left: <https://commons.wikimedia.org/>; right: CFCSL <https://www.cfcsl.com/>

Steel and composite girders – Typical cross-sections and details

Slenderness h/l for steel beams

Usual slenderness h/l for steel girders in road bridges		
Type of beam	Structural form	
	Simple beam h/l	Continuous beam h/l
Plate girder	1/18 ... 1/12	1/28 ... 1/20
Box girder	1/25 ... 1/20	1/30 ... 1/25
Truss	1/12 ... 1/10	1/16 ... 1/12

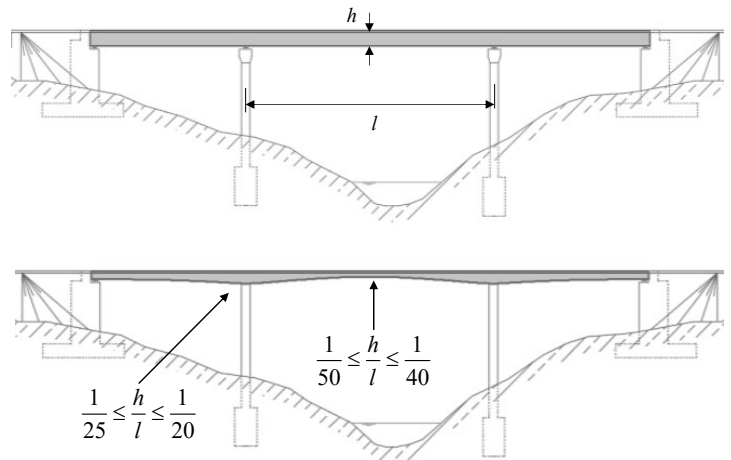

Source: J.P. Lebet and M.A. Hirt, Steel bridges

Steel and composite girders – Typical cross-sections and details

Web and flange dimensions

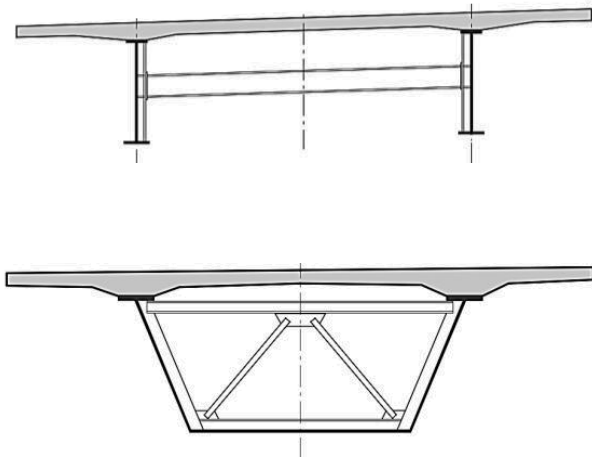

Web and flange dimensions for plate girders [mm]				
Dimension		Notation	In span	At support
Thickness	Top flange	$t_{f,sup}$	15 ... 40	20 ... 70
	Bottom flange	$t_{f,inf}$	20 ... 70	40 ... 90
	Web	t_w	10 ... 18	12 ... 22
Width	Top flange	$b_{f,sup}$	300 ... 700	300 ... 1200
	Bottom flange	$b_{f,inf}$	400 ... 1200	500 ... 1400

Web and flange dimensions for box girders [mm]				
Dimension		Notation	In span	At support
Thickness	Top flange	$t_{f,sup}$	16 ... 28	24 ... 40
	Bottom flange	$t_{f,inf}$	10 ... 28	24 ... 50
	Web	t_w	10 ... 14	14 ... 22

Source: J.P. Lebet and M.A. Hirt, Steel bridges

Top photo: Plate girders, Viaduct over the Mularroya Dam, Spain © IDEAM

Bottom photo: Box girder, Highway A-357, Guadalhorce-Connection, Spain © IDEAM

Steel and composite girders – Typical cross-sections and details

Web and flange dimensions



Web and flange dimensions for plate girders [mm]				
Dimension		Notation	In span	At support
Thickness	Top flange	$t_{f,sup}$	15 ... 40	20 ... 70
	Bottom flange	$t_{f,inf}$	20 ... 70	40 ... 90
	Web	t_w	10 ... 18	12 ... 22
Width	Top flange	$b_{f,sup}$	300 ... 700	300 ... 1200
	Bottom flange	$b_{f,inf}$	400 ... 1200	500 ... 1400



Web and flange dimensions for box girders [mm]				
Dimension		Notation	In span	At support
Thickness	Top flange	$t_{f,sup}$	16 ... 28	24 ... 40
	Bottom flange	$t_{f,inf}$	10 ... 28	24 ... 50
	Web	t_w	10 ... 14	14 ... 22

Source: J.P. Lebet and M.A. Hirt, Steel bridges

Top photo: Plate girders, bridge over the Serpis river in Gandía, Spain © IDEAM

Bottom photo: Box girder, Viaduct over the Tajo river in Talavera de la Reina, Spain © IDEAM

Superstructure / Girder bridges

Design and erection

Steel and steel-concrete composite girders

Structural analysis and design – General remarks

Structural analysis and design – General Remarks

Overview

- Major differences compared to building structures
- Spine and grillage models usual
- Usually significant eccentric loads → torsion relevant
- Basically, the following analysis methods (see lectures Stahlbau) are applicable also to steel and steel-concrete composite bridges:
 - PP: Plastic analysis, plastic design (rarely used in bridges)
 - EP: Elastic analysis, plastic design
 - EE: Elastic analysis, elastic design
 - EER: Elastic analysis, elastic design with reduced section
- Linear elastic analysis is usual, without explicit moment redistribution → Methods EP, EE, EER usual, using transformed section properties (ideelle Querschnittswerte)
- Moving loads → design using envelopes of action effects
- Steel girders with custom cross-sections (slender, welded plates) are common for structural efficiency and economy
 - plate girders (hot-rolled profiles only for secondary elements)
 - stability essential in analysis and design
 - slender plates require use of Method EE or even EER



Redistributions of internal stresses are virtually always relied upon, even if temperature gradients and differential settlements are accounted for in the structural analysis: An initially stress-free structure is commonly assumed, but there are always significant internal restraint stresses, in e.g. due to hydration heat and differential shrinkage throughout concrete sections, and residual welding stresses in steel elements. This is the reason why concrete tensile stresses must not be accounted for in primary load-carrying mechanisms.

Photo: Puente sobre el Embalse del Ebro, Reinosa-Corconte, Cantabria ES, Arenas y asociados, 2001. © W. Kaufmann

Ladder deck, using precast slab elements serving as integrated formwork for the cast in place deck.

Structural analysis and design – General Remarks

Overview

- Construction is usually staged (in cross-section)
→ see behind
- Fatigue is the governing limit state in many cases in bridges
→ limited benefit of high strength steel grades
→ avoid details with low fatigue strength
→ see lectures Stahlbau (only selected aspects treated here)
- Camber is often required and highly important (steel girders often require large camber)
→ as in concrete structures: no «safe side» in camber
→ account for long-term effects
(creep and shrinkage of concrete deck)
→ account for staged construction
- Shear transfer between concrete deck and steel girders needs to be checked in composite bridges
→ see shear connection
- Effective width to be considered. Figure shows values for concrete flanges, steel plates see EN 1993-1-5

Effective width of concrete deck in a composite girder used for global analysis (EN1994-2)

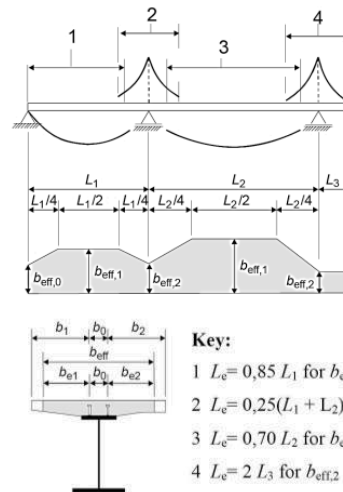

Interior support / midspan:

$$b_{eff} = b_0 + \sum_{i=1}^2 b_{ei}$$

$$b_{ei} = \frac{L_e}{8} \leq b_i$$

End support:

$$b_{eff} = b_0 + \sum_{i=1}^2 \beta_i b_{ei}$$

$$\beta_i = \left(0.55 + 0.025 \frac{L_e}{b_{ei}} \right) \leq 1$$

Key:

1 $L_e = 0,85 L_1$ for $b_{eff,1}$

2 $L_e = 0,25(L_1 + L_2)$ for $b_{eff,2}$

3 $L_e = 0,70 L_2$ for $b_{eff,1}$

4 $L_e = 2 L_3$ for $b_{eff,2}$

Illustration: EN1994-2 (2005)

Structural analysis and design – General Remarks

Slender plates

- In order to save weight and material, slender steel plates are often used in bridges (particularly for webs and wide flanges of box girders)
 - Plate buckling cannot be excluded a priori (unlike hot-rolled profiles common in building structures)
 - Analysis method depends on cross-section classes (known from lectures Stahlbau, see figure)
- The steel strength cannot be fully used in sections of Class 3 or 4 (resp. the part of the plates outside the effective width is ineffective)
 - For structural efficiency, compact sections (Class 1+2) are preferred
 - To achieve Class 1 or 2, providing stiffeners is structurally more efficient than using thicker plates (but causes higher labour cost)
 - Alternatively, use sections with double composite action (compression carried by concrete, which is anyway more economical to this end)

Internal compression parts (beidseitig gestützte Scheiben)

Class	bending	compression	bending + compression			
Stress distribution in parts (compression positive)						
Class 1	S355: $c/t \leq 58$	S355: $c/t \leq 27$	when $\alpha > 0.5$: $c/t \leq \frac{396\epsilon}{13\alpha - 1}$ S355: $c/t \leq 27 \dots 58$ when $\alpha \leq 0.5$: $c/t \leq \frac{36\epsilon}{\alpha}$			
Class 2	S355: $c/t \leq 67$	S355: $c/t \leq 30$	when $\alpha > 0.5$: $c/t \leq \frac{456\epsilon}{13\alpha - 1}$ S355: $c/t \leq 30 \dots 67$ when $\alpha \leq 0.5$: $c/t \leq \frac{41.5\epsilon}{\alpha}$			
Stress distribution in parts (compression positive)						
Class 3	S355: $c/t \leq 100$	S355: $c/t \leq 34$	when $\psi > -1$: $c/t \leq \frac{42\epsilon}{0.67 + 0.33\psi}$ when $\psi \leq -1$: $c/t \leq 62\epsilon(1 - \psi)\sqrt{(-\psi)}$			
$\epsilon = \sqrt{235/f_y}$	f_y	235	275	355	420	460
	ϵ	1.00	0.92	0.81	0.75	0.71

*) $\psi \leq -1$ applies where either the compression stress $\sigma \leq f_y$ or the tensile strain $\epsilon_t > f_y/E$

Table adapted from EN1993-1-1, table 5.2 (corresponds to SIA 263, table 5)

Structural analysis and design – General Remarks

Slender plates

- In order to save weight and material, slender steel plates are often used in bridges (particularly for webs and wide flanges of box girders)
 - Plate buckling cannot be excluded a priori (unlike hot-rolled profiles common in building structures)
 - Analysis method depends on cross-section classes (known from lectures Stahlbau, see figure)
- The steel strength cannot be fully used in sections of Class 3 or 4 (resp. the part of the plates outside the effective width is ineffective)
 - For structural efficiency, compact sections (Class 1+2) are preferred
 - To achieve Class 1 or 2, providing stiffeners is structurally more efficient than using thicker plates (but causes higher labour cost)
 - Alternatively, use sections with double composite action (compression carried by concrete, which is anyway more economical to this end)

Outstand flanges (einseitig gestützte Scheiben)

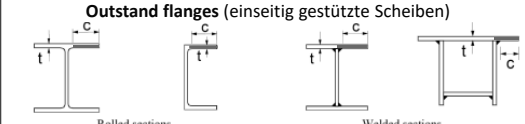

Class	compression	bending + compression				
		tip in compression	tip in tension			
Stress distribution						
Stress distribution in parts (compression positive)						
Class 1	S355: $c/t \leq 7$	S355: $c/t \leq 7/\alpha$	S355: $c/t \leq 7/\alpha^{1.5}$			
Class 2	S355: $c/t \leq 8$	S355: $c/t \leq 8/\alpha$	S355: $c/t \leq 8/\alpha^{1.5}$			
Stress distribution in parts (compression positive)						
Class 3	S355: $c/t \leq 11$	S355: $c/t \leq 17 \cdot k_{\sigma}^{0.5}$				
$\epsilon = \sqrt{235/f_y}$	f_y	235	275	355	420	460
	ϵ	1,00	0,92	0,81	0,75	0,71

For plates with stiffeners (common in bridges) follow EN 1993-1-5

Table adapted from EN1993-1-1, table 5.2 (corresponds to SIA 263, table 5)

Structural analysis and design – General Remarks

Steel connections

- As in other steel structures, connections can be bolted or welded
 - In the shop (Werkstatt), welded connections are common
 - On site, bolted or welded connections are used, depending on the specific detail, erection method and local preferences (e.g. most site connections welded in CH/ESP, while bolted connections are preferred in USA)
- Bolted connections are easier and faster to erect, but require larger dimensions and may be aesthetically challenging. Slip-critical connections, using high strength bolts, are typically required in bridges (HV Reibungsverbindungen)
- Connections welded on site are more demanding for execution and control, but can transfer the full member strength without increasing dimensions (full penetration welds). Temporary bolted connections are provided to fix the parts during welding
- Careful detailing is relevant for the fatigue strength of both, bolted and welded (more critical) connections.

Example of welded erection joint

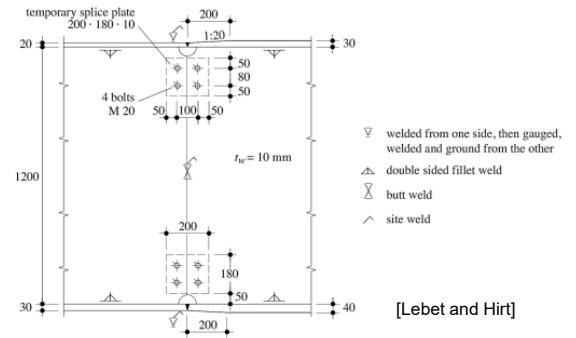

Example of bolted frame cross bracing

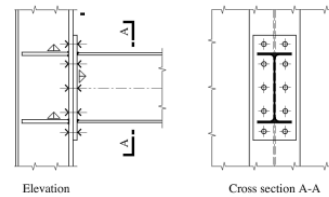

Illustrations: Lebet and Hirt, Steel Structures

Structural analysis and design – General Remarks

Transformed section properties
(ideelle Querschnittswerte)

- In the global analysis, transformed section properties (ideelle Querschnittswerte) are used, with the modular ratio $n = E_a / E_c$:

$$A_i = \int \frac{dA}{n}, \quad \zeta_c = \frac{\int \zeta \cdot \frac{dA}{n}}{A_i}, \quad I_{yi} = \int z^2 \cdot \frac{dA}{n}, \quad \text{etc.}$$

- In composite girders, steel is commonly used as reference material (unlike reinforced concrete; n_{el} : “Reduktionszahl”, not “Wertigkeit”, see notes)
- Using the subscripts “a”, “c” and “b” for steel, concrete and composite section, the equations shown in the figure apply (in many cases, the concrete moment of inertia I_{yc} is negligible)
- Reinforcement can be included in the “concrete” contributions (figure); in compression, the gross concrete area is often used, i.e., the reinforcement in compression is neglected

Transformed section properties for composite section

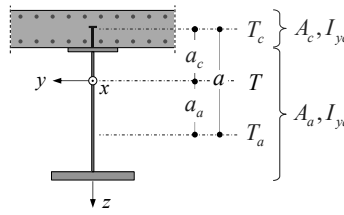

$$\left. \begin{aligned} & \left. \begin{aligned} & A_c, I_{yc} \\ & T_c \end{aligned} \right\} \\ & \left. \begin{aligned} & A_a, I_{ya} \\ & T_a \end{aligned} \right\} \end{aligned} \right\} \begin{aligned} A_b &= A_a + \frac{A_c}{n} \\ a_a &= a \frac{A_c/n}{A_b}, \quad a_c = a \frac{A_a}{A_b} \\ I_{yb} &= I_{ya} + a_a^2 A_a + \frac{I_{yc}}{n} + a_c^2 \frac{A_c}{n} \\ &= I_{ya} + \frac{I_{yc}}{n} + a_a a_c A_b \end{aligned}$$

T : Centroid of composite section
 T_a : Centroid of steel section
 T_c : Centroid of concrete section (incl. reinforcement)

Accounting for reinforcement in “concrete” area

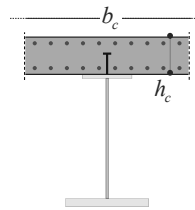

$$\rho = \frac{A_s}{h_c b_c}, \quad n_s = \frac{E_s}{E_c}$$

- uncracked: $A_c = h_c b_c (1 - \rho + n_s \rho) \approx h_c b_c$
- fully cracked: $A_c = h_c b_c \cdot n_s \rho$
(neglecting tension stiffening)

Where transformed sections (ideelle Querschnitte) are used, i.e., the concrete parts of the composite cross-section are accounted for with a reduced cross-section, the reduction corresponding to the modular ratio $n = E_a / E_{c,eff}(t)$.

Note that in composite bridge design, contrary to reinforced concrete analysis, steel is conventionally used as reference material, but the definition $n = E_a / E_c$ is maintained (i.e., $n > 1$). The transformed section properties (ideelle Querschnittswerte) A_i, I_{yi} etc. are referred to E_a , and concrete areas have to be **divided by n**: Axial stiffness “ EA ” = $E_a A_i$, bending stiffness “ EI ” = $E_a I_i$ etc. Consequently, $A_i = A_a + A_c / n$ (rather than $A_i = A_c + n A_s$ in reinforced concrete). Therefore, the modular ratio is referred to as “Reduktionszahl” (rather than “Wertigkeit” as in concrete) in the German version of EN 1994.

Structural analysis and design – General Remarks

Modular ratio – effective concrete modulus $E_{c,eff}$

- Elastic stiffnesses are commonly used for global analysis (strictly required in Methods EE and EER, but also common for EP)
- The modular ratio n depends on the long-term behaviour of the concrete
- A realistic analysis of the interaction, accounting for creep, shrinkage and relaxation is challenging
- An approximation using the effective modulus $E_{c,eff}(t)$ of the concrete is sufficient in most cases
 - SIA 264 recommends the values for $E_{c,eff}(t)$ shown in the figure, from which $n_{el} = E_a / E_{c,eff}(t)$ is obtained (only applicable for $t=t_{\infty}$)
 - EN1994-2 uses refined equations, which yield **GSA1** similar results (e.g. for $\varphi=2$, ca. 5% lower $E_{c,eff}$ **KW1** using SIA 264)
- These approaches are semi-empirical and do not account for cracking, but they are simple to use and yield reasonable results in normal cases.

SIA 264 (2014)

for normal and
lightweight concrete,
 $20 \text{ MPa} \leq f_{ck} \leq 50 \text{ MPa}$

$$\left\{ \begin{array}{l} E_{c,eff} = E_{cm} \rightarrow \text{short term} \\ E_{c,eff} = E_{cm}/3 \rightarrow \text{long term} \\ E_{c,eff} = E_{cm}/2 \rightarrow \text{shrinkage} \end{array} \right.$$

EN 1994-2:2005

modular ratio n
depending on
... concrete age (t)
... loading type (L)

$$\left\{ \begin{array}{l} n_L = \frac{E_a}{E_{cm}} (1 + \psi_L \varphi(t, t_0)) \\ \psi_L = 0.00 \rightarrow \text{short term} \\ \psi_L = 1.10 \rightarrow \text{long term} \\ \hspace{10em} (\text{permanent loads}) \\ \psi_L = 0.55 \rightarrow \text{shrinkage} \\ \psi_L = 1.50 \rightarrow \text{"prestressing" by} \\ \hspace{10em} \text{imposed deformations} \end{array} \right.$$

For non-standard cases (e.g. double composite action), more refined approaches (see e.g. Advanced Structural Concrete, Trost's Method) may be used.

Structural analysis and design – General Remarks

Methods of analysis: Overview

In global analysis, the effects of shear lag and plate buckling are taken into account for all limit states:

- Ultimate limit states ULS (EN 1990) / Structural safety limit states (SIA 260): STR = Type 2), FAT = Type 4 (see notes)
- SLS = serviceability limit states

→ use correspondingly reduced stiffnesses of members and joints in structural analysis

As already mentioned, a fully plastic design (Method PP) is unusual in bridges. Rather, internal forces are determined from a linear elastic analysis (EP, EE or EER).

However, redistributions are implicitly relied upon, see “Bridge specific design aspects”. This particularly applies if thermal gradients and differential settlements are neglected in a so-called “EP” analysis (as often done in CH, which is thus rather “PP”).

Method analysis for steel and steel-concrete composite girders				
Method	Internal forces (analysis)	Resistance (dimensioning)	Suitable for Cross-section	Use for Limit state ⁽¹⁾
PP	Plastic	Plastic	Class 1	STR
EP	Elastic	Plastic	Classes 1/2	STR
EE ⁽²⁾	Elastic	Elastic	Classes 1/2/3	STR FAT SLS
EER ⁽²⁾	Elastic	Elastic Reduced	Class 4 ⁽³⁾	STR FAT SLS

Cross-section classes depend on plate slenderness, see following slides and lectures Stahlbau

¹⁾ Here and in the following, the abbreviations for limit states of Eurocodes are used:

- **ULS STR** = *structural safety, limit state type 2* according to SIA 260 (reaching of the ultimate resistance of the structure or one of its structural members, i.e., failure due to rupture, excessive deformations, the structure forming a mechanism, or loss of stability of one or multiple structural members)
- **ULS FAT** = *structural safety, limit state type 4* according to SIA 260 (reaching the fatigue resistance of the structure or one of its structural members)

Note that “ULS” is sometimes used as synonym for ULS STR, and FAT for ULS FAT although “ULS” may refer to EQU, STR, GEO and FAT limit states (structural safety limit states type 1-4 according to SIA 260)

²⁾ For a strictly elastic verification, all actions must be considered to obtain the stress distributions, including differential settlements, thermal gradients etc. Furthermore, the designation “EE” must not be misunderstood in the sense, that the entire cross-section needs to remain elastic in ULS. Rather, inelastic tensile strains are allowed in cross-sectional analysis (to determine e.g. the bending resistance) when using Method EE with cross-section Class 3.

³⁾ According to EN 1993-1-5: 2006 (General rules - Plated structural elements), the effect of plate buckling on the stiffness may be ignored if the effective cross-sectional area (over which the full yield stress is assumed) of an element in compression is larger than ρ_{lim} times the gross cross-sectional area of the same element. The parameter ρ_{lim} may be specified in the National Annexes ($\rho_{lim} = 0,5$ is recommended, and the Swiss NA adopts does not change this default value).

For structural efficiency, plates should be stiffened such that the effective cross-sectional area is not severely reduced. Hence, the full cross-section may be used when determining internal actions for such plates. An exception are webs of plate girders, whose effective width in bending (longitudinal compression on compressed side of web) is often significantly reduced. Since the webs contribute very little to the bending stiffness, using the full cross-section in structural analysis is still common practice in these cases.

Structural analysis and design – General Remarks

Methods of analysis: Overview

Table remarks (see notes page for details)

- 1) Abbreviations used hereafter:
 ULS STR = *structural safety, limit state type 2* (failure of structure or structural member)
 ULS FAT = *structural safety, limit state type 4* (fatigue)
- 2) For a strictly elastic verification, all actions must be considered (including thermal gradients, differential settlements etc).
- 3) EN 1993-1-5: 2006 (General rules - Plated structural elements) requires to account for the effect of plate buckling on stiffnesses if the effective cross-sectional area of an element in compression is less than $\rho_{lim} = 0.5$ times its gross cross-sectional area. This is rarely the case (such plates are structurally inefficient). If it applies to webs, it is usually neglected since they have a minor effect on the bending stiffness of the cross-section (shear deformations are neglected).

Method analysis for steel and steel-concrete composite girders				
Method	Internal forces (analysis)	Resistance (dimensioning)	Suitable for Cross-section	Use for Limit state ⁽¹⁾
PP	Plastic	Plastic	Class 1	STR
EP	Elastic	Plastic	Classes 1/2	STR
EE ⁽²⁾	Elastic	Elastic	Classes 1/2/3	STR FAT SLS
EER ⁽²⁾	Elastic	Elastic Reduced	Class 4 ⁽³⁾	STR FAT SLS

Cross-section classes depend on plate slenderness, see following slides and lectures Stahlbau

Structural analysis and design – General Remarks

Overview of required checks in ultimate limit state design

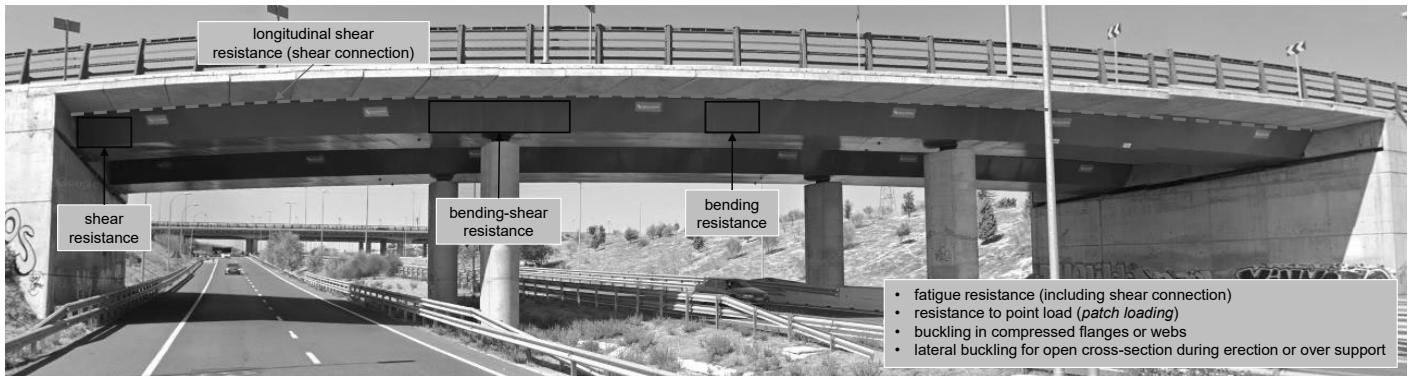

Superstructure / Girder bridges

Design and erection

Steel and steel-concrete composite girders

Structural analysis and design – Staged construction

Structural analysis and design – General Remarks

Staged construction

- Construction is often staged
 - account for staged construction in analysis
 - challenging in composite girders since the cross-section typically changes and
 - time-dependent effects need to be considered (concrete creeps and shrinks, steel does not)
- In many situations, it is useful to subdivide the internal actions into forces in the
 - steel girder M_a, N_a (tension positive)
 - concrete deck M_c, N_c (compression positive) (including reinforcement)

Strains and stresses for loads applied to steel girders ($N=0$ shown)

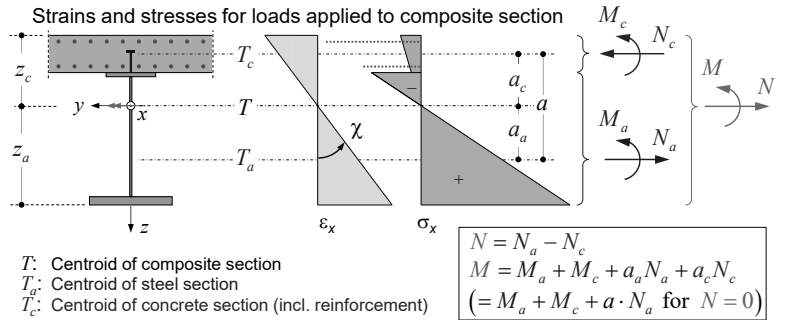
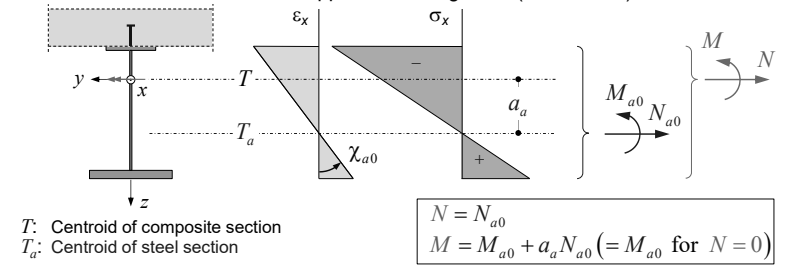

Note that the assumption of plane sections remaining plane holds true per construction change, i.e. for each cross-section at the time of load application. The total strains are, however, not linear over the depth if the steel girders carry load alone, before being connected to the concrete deck.

Structural analysis and design – General Remarks

Calculation of action effects in staged construction

- A global, staged linear elastic analysis is usually carried out
- Cracking of the deck and long-term effects are considered by using appropriate modular ratios $n = E_s / E_{c,eff}(t)$ to determine member stiffnesses
- Actions are generally applied to static systems with varying supports and cross-sections.
- Typically
 1. The steel girders are erected and carry their self-weight (often with temporary shoring)
 2. The concrete deck is cast on a formwork supported by the steel girders (often with temporary shoring)
 3. The formwork and temporary shoring are removed (apply negative reactions!)
 4. The superimposed dead loads are applied (long-term concrete stiffness, see Method EE)
 5. The variable loads are applied (short-term concrete stiffness, see Method EE)

1. Erection of steel girders with temporary shoring
2. Casting of concrete deck (on steel girders)

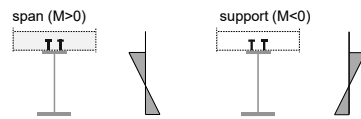

3. Removal of formwork and temporary shoring
4. Superimposed dead load (surfacing, parapets, ...)

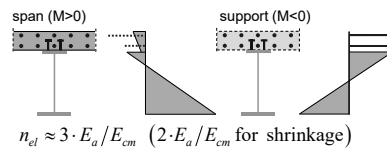

5. Envelope of variable loads (traffic, wind, further short-term loads)

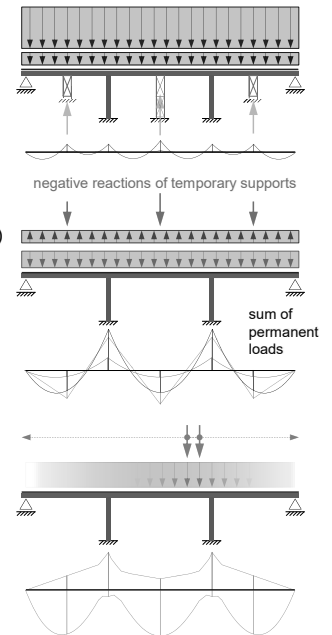
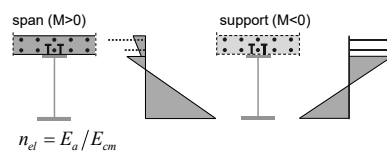

03.03.2025

ETH Zürich | Chair of Concrete Structures and Bridge Design | Bridge Design Lectures

24

For steel-concrete composite bridges, the self-weight of the slab usually acts on the steel structure alone (unless the deck is cast in-situ on a formwork supported continuously by falsework on the ground, which is rarely the case). Hence:

- The steel girders alone carry their self weight and the weight of the concrete during casting
- The steel-concrete composite girders resist all loads applied after hardening of the concrete (= establishing the longitudinal shear connection between steel and concrete)

The actions are thus applied to a static system with different cross-section. The analysis is further complicated since:

- Additional, temporary supports to the steel girders are often provided during casting of the deck
- The concrete deck is often cast in stages (typically midspan sections first, pier sections last)
- The concrete deck usually cracks over the piers, shrinks and creeps under sustained loads

Structural analysis and design – General Remarks

Calculation of action effects in staged construction

- Essentially:
 - steel girders carry loads alone until concrete deck has hardened and connection steel-concrete is established (stages 1+2)
 - composite girders carry all loads thereafter (stages 3 ff), considering concrete creep by an appropriate modular ratio
- The total action effects are obtained as the sum of action effects due to each action, applied to the static system (supports, cross-sections) active at the time of their application
- If temporary supports are removed, it is essential to apply the (negative) sum of their support reactions from previous load stages as loads to the static system at their removal
- This general procedure is not unique to steel and composite bridges, but used for the staged analysis of any structure

- Erection of steel girders with temporary shoring
- Casting of concrete deck (on steel girders)

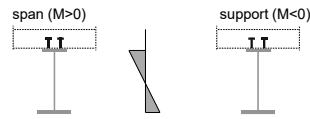

3. Removal of formwork and temporary shoring
4. Superimposed dead load (surfacing, parapets, ...)

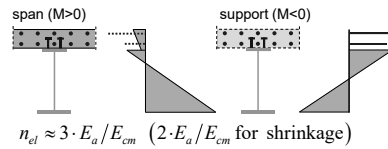

5. Envelope of variable loads (traffic, wind, further short-term loads)

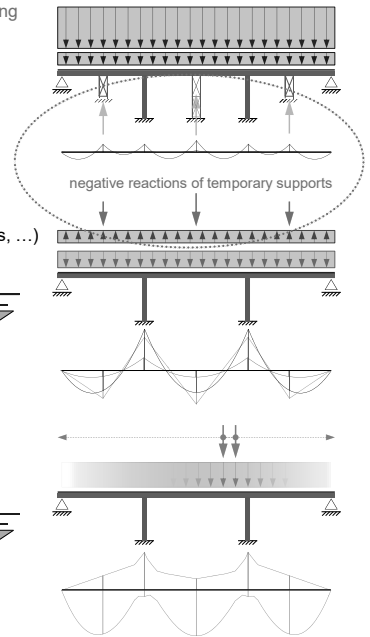
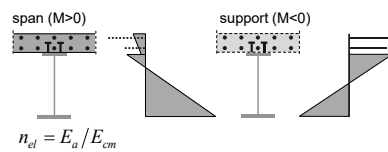

Superstructure / Girder bridges

Design and erection

Steel and steel-concrete composite girders

Structural analysis and design – Elastic-plastic design (EP)

Structural analysis and design – Elastic-plastic design (EP)

Elastic-plastic design (Method EP)

- For compact sections (class 1 or 2), the structural safety (limit state type 2 = STR) may basically be verified using the plastic bending resistance of the cross-section (Method EP), using

→ $M_{Ed} = M_{Ed}(G) + M_{Ed}(Q)$ total action effects
(sum of action effects due to each action in appropriate system)

→ $M_{Rd} = M_{pl,Rd}$ = full plastic resistance of section

This essentially corresponds to the ULS verification of concrete bridges based on an elastic (staged) global analysis

Typically, compact sections are present

→ in the span of composite girders (deck in compression, steel in tension)

→ over supports in girders with double composite action (concrete bottom slab)

- Activating the full $M_{pl,Rd}$ requires rotation capacity not only in the section under consideration → in some cases, even if the section is compact, $M_{pl,Rd}$ needs to be reduced by 10% (see following slides)

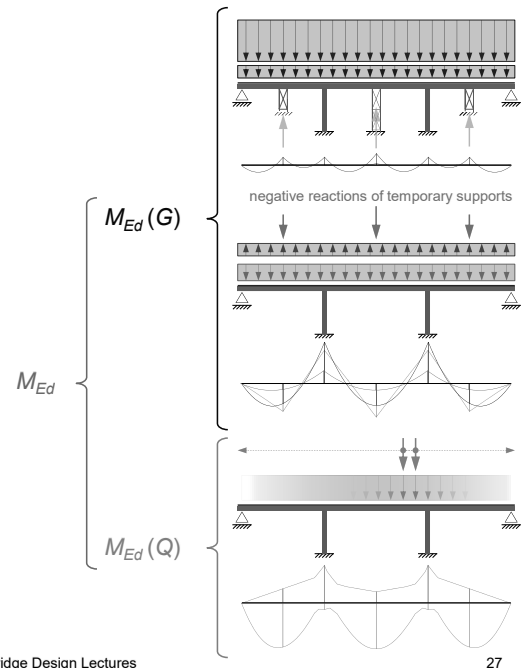

Here and in the following slides, the factored action effects are designated by subscript “Ed” (EC) rather than simply “d” as in SIA codes.

Structural analysis and design – Elastic-plastic design (EP)

Elastic-plastic design (Method EP)

Plastic resistance

- The plastic bending resistance of composite cross-sections of Class 1 or 2 is calculated similarly as in reinforced concrete (see figure)
 - neglect tensile stresses in concrete
 - assume yielding of steel and reinforcement
 - rectangular stress block for concrete in compression ($0.85 \cdot f_{cd}$ over depth x , rather than f_{cd} over $0.85 \cdot x$)
 - assume full connection (plane sections remain plane)
- The use of the plastic resistance simplifies analysis:
 - no need to account for “load history” in sections
 - no effect of residual stresses / imposed deformations
- The following points must however be addressed:
 - ductility of the composite cross section → next slide
 - moment redistribution in cont. girders → next slide
 - serviceability (avoid yielding in SLS → next slide)
 - shear connection (see separate section)

Plastic bending resistance of a composite beam with a solid slab and full shear connection according to EN1994-2:

Sagging / positive bending ($x_{pl} < h_c$; case $x_{pl} > h_c$ see slide for S420/460)

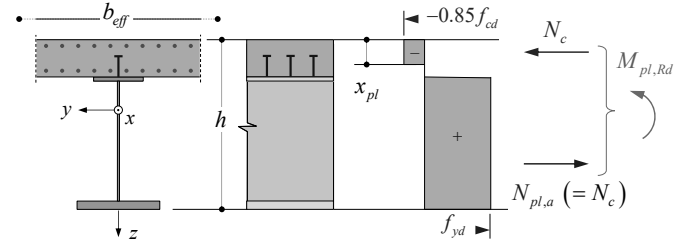

Hogging / negative bending

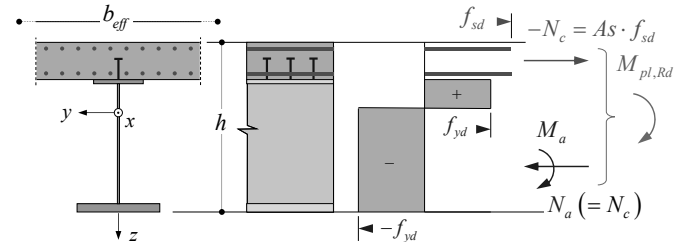

The plastic resistance of a composite cross-section can be used where there is no risk of buckling of slender steel plates. This applies generally in the regions of positive moment (almost entire steel section in tension), and also for negative moments in the case of double composite action (or appropriately stiffened bottom flanges / webs). The following assumptions are commonly made in the calculation of $M_{pl,Rd}$:

- full interaction between structural steel, reinforcement, and concrete (plane sections remain plane, i.e. linear longitudinal strain distribution)
- the structural steel member yields in tension or compression (design yield strength f_{yd}).
- the longitudinal reinforcement yields in tension or compression (design yield strength f_{sd}). Often, reinforcement in compression in a concrete slab is neglected.
- the concrete in compression resists a stress of $0.85 \cdot f_{cd}$, constant over the full depth between the (plastic) neutral axis and the most compressed fibre of the concrete.

See *Stahl- und Verbundbau* lecture for the calculation of the design value of the plastic moment resistance $M_{pl,Rd}$ in more general cases.

Note that in the calculation of the bending resistance of cross-sections of Class 3, inelastic strains are allowed in slender plates of the section subjected to tension (“partial plastic resistance”). Such an analysis is referred to as “non-linear theory for calculating bending resistance”, rather than “plastic resistance”; the stresses in the different cross-sectional components need to be calculated, just like when using Method EE or EER (see behind), in order to calculate the strains (stresses) in the compressed parts of the steel section. Many designers prefer, however, to ensure ductile behaviour by providing stiffeners such that the section complies with the criteria for Class 2.

Structural analysis and design – Elastic-plastic design (EP)

Elastic-plastic design (Method EP)

Plastic resistance

- In order to reach the full plastic resistance $M_{pl,Rd}$, significant (theoretically infinite) curvature and hence, inelastic rotations, are required
- The rotations required to reach $M_{pl,Rd}$ at midspan of a continuous girder generally may require inelastic rotations in other parts of the girder, particularly over supports.
- This particularly applies to girders that are not propped during construction (steel girders carry wet concrete over full span), see figure: Larger inelastic rotations are required in to reach $M_{pl,Rd}$
- To avoid problems related to rotation capacity, EN1994-2 requires to reduce the bending resistance to $M_{Rd} \leq 0.9 \cdot M_{pl,Rd}$ if:
 - the sections over adjacent supports are not compact (i.e. class 3 or 4 rather than 1 or 2), which is often the case
 - the adjacent spans are much longer or shorter, i.e. if $l_{min} / l_{max} < 0.6$
- For more detailed information see notes.

Typical moment-curvature relationships of composite girders (adapted from Lebet and Hirt, Steel Bridges):

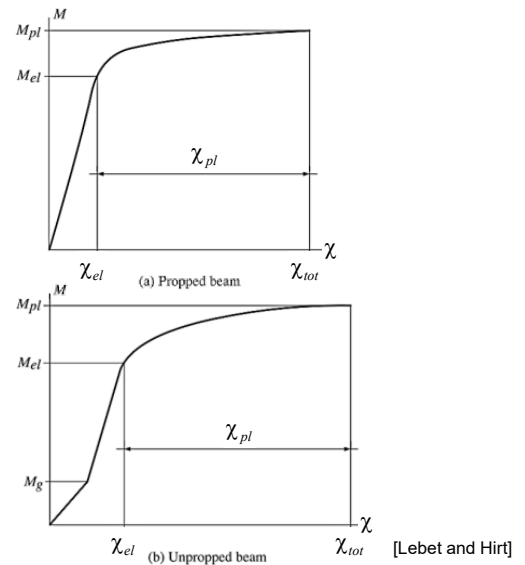

A large curvature is required to reach the full plastic moment resistance in both, propped and unpropped girders. In unpropped girders, they are even larger, since the steel girder alone has to carry the wet concrete weight and plastification of the section starts at a lower level of load, represented by M_{pl} . It is difficult to achieve the full plastic resistance, specially for continuous beams, because of the large amount of curvature required. During these rotations, it is possible that the section at an adjacent support fails due to instability if it is not compact (typically critical: vertical buckling of compression flange into web).

Rather than simply reducing the bending resistance by 10% if the sections over adjacent supports are not compact, as proposed by EN1994-2, Lebet and Hirt propose the following:

- Using the plastic resistance $M_{pl,Rd}$ is only allowed if the ratio between adjacent span greater than 0.6 ($l_{min} / l_{max} \geq 0.6$)
- $M_{Rd} = 0.95 \cdot M_{pl,Rd}$, for beams that are propped during erection
- $M_{Rd} = 0.90 \cdot M_{pl,Rd}$, for beams that are unpropped during erection

(see J.P. Lebet and M.A. Hirt, Steel bridges, for more details)

Illustration adapted from J.P. Lebet and M.A. Hirt, Steel bridges

Structural analysis and design – Elastic-plastic design (EP)

Elastic-plastic design (Method EP)

Plastic resistance

- Apart from rotation capacity, the shear connection also needs to be designed to enable the utilisation of $M_{pl,Rd}$
→ see the corresponding section
- Plastic design may lead to situations where inelastic strains occur under service conditions. This could occur particularly in unpropped girders, but should be avoided
→ check stresses (as outlined in section on Method EE) in service conditions (characteristic combination) to make sure the section remains elastic, i.e., $M_{Ed,SLS} \leq M_{el,Rd}$
- If high strength steel (Grade S420 or S460) is used, even larger strains (and curvatures) are required to reach $M_{pl,Rd}$. Therefore, a further reduction of $M_{pl,Rd}$ by a factor β is appropriate if $x/h > 0.15$, see figure.

$$M_{Rd} = \beta \cdot M_{pl,Rd}$$

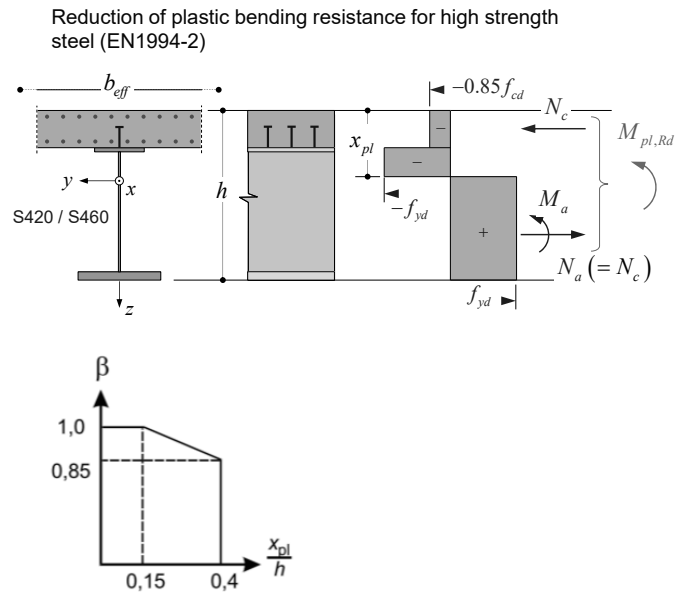

Note that the reduction for high-strength steel is likely to be overly conservative, and will probably be changed in the upcoming revision of EN1994.

Illustrations adapted from EN 1994-2:2005

Superstructure / Girder bridges

Design and erection

Steel and steel-concrete composite girders

Structural analysis and design – Elastic design (EE, EER)

Structural analysis and design – Elastic design (EE, EER)

Elastic design (EE, EER)

- If the relevant cross-sections are not compact (Class 3 or 4), Method EP cannot be used → Elastic resistance $M_{el,Rd}$ must be used (Method EE: full steel section, EER: reduced steel section)
- Since $M_{el,Rd}$ is defined by reaching the design yield stress in any fibre of the cross-section, the load history in the sections needs to be considered, i.e., rather than merely adding up bending moments and normal forces, the stresses throughout the section need to be summed up
- A global, staged linear elastic analysis is thus carried out to
 - ... determine action effects (as in Method EP)
 - ... determine stresses in cross-sections
- The total stresses in each fibre of a cross-section are obtained as the sum of the stresses caused by each action (load step) acting on the static system (supports, cross-sections) active at the time of its application.

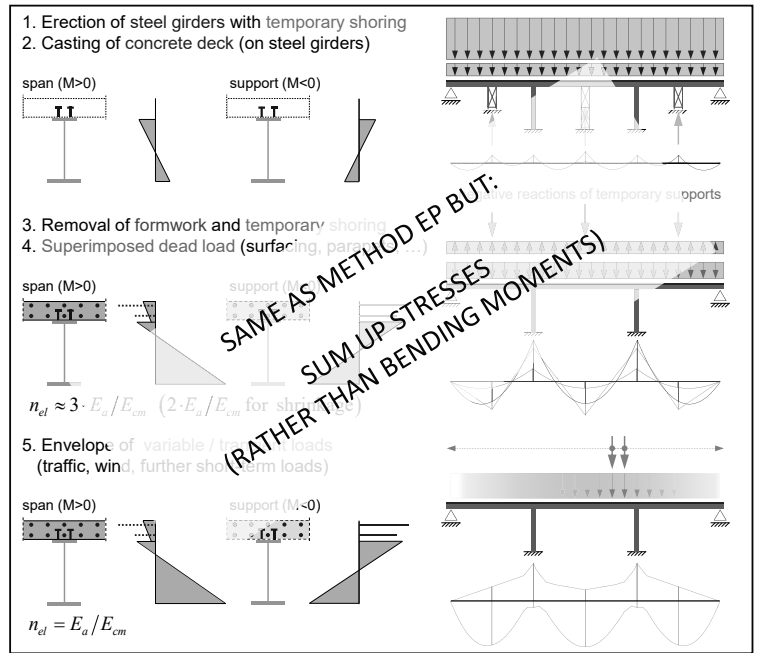

Structural analysis and design – Elastic design (EE, EER)

Elastic design (EE, EER)

- Note that while $M_{el,Rd}$ follows from the steel, concrete and reinforcement stresses ($\sigma_{a,Ed}$, $\sigma_{c,Ed}$ and $\sigma_{s,Ed}$) by integration over the section, the stresses cannot be determined from $M_{el,Rd}$ (not even by iteration) since they depend on the load history.

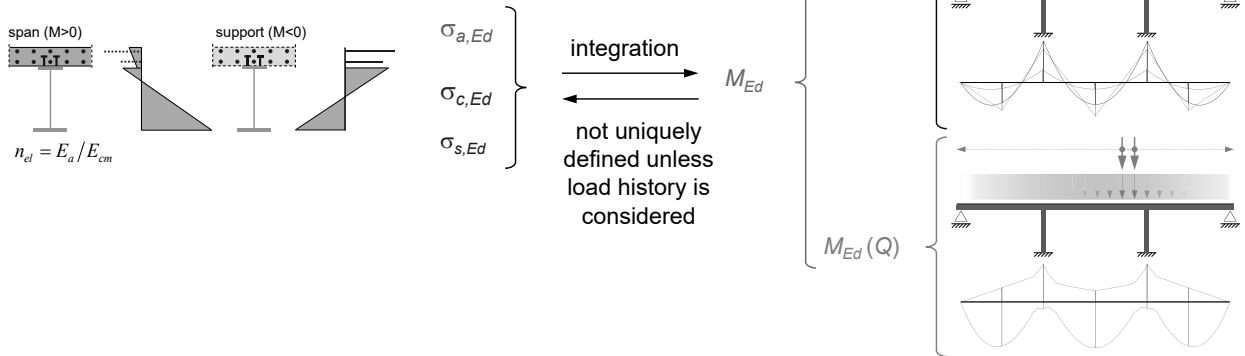

Here and in the following slides, the factored action effects are designated by subscript “Ed” (EC) rather than simply “d” as in SIA codes.

Structural analysis and design – Elastic design (EE, EER)

Elastic design (EE, EER)

- The stresses in steel, concrete and reinforcement ($\sigma_{a,Ed}$, $\sigma_{c,Ed}$ and $\sigma_{s,Ed}$) depend on the construction sequencing
- In particular, as illustrated in the figure, there are significant differences between
 - a bridge unpropped during construction (steel girders carry formwork and weight of concrete deck at casting)
 - a bridge totally propped during construction (deck cast on formwork supported by independent falsework / shoring)
- The elastic resistance $M_{el,Rd}$ is reached when the steel reaches the design yield stress $\sigma_{a,Ed} = f_y / \gamma_a$ or the concrete reaches a nominal stress of $\sigma_{c,Ed} = 0.85 \cdot f_{cd} = 0.85 \cdot f_{ck} / \gamma_c$
- steel is more likely governing in case (a), concrete in case (b)

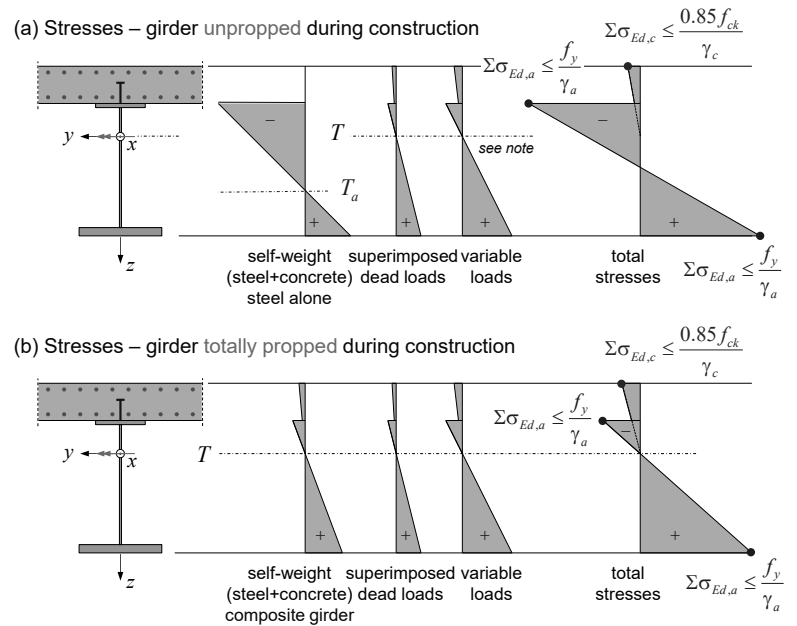

The difference in the position of the centroid for short-term and long-term loads (different effective modulus of concrete, centroid lower for long-term loads) has been neglected for simplification. Figure adapted from Lebet and Hirt, Steel bridges.

Structural analysis and design – Elastic design (EE, EER)

Elastic design (EE, EER)

Elastic stiffnesses

- On this and the following slide, the considered sections and modular ratios recommended by SIA 264 are summarised.

Span / sagging moments
(deck in compression)

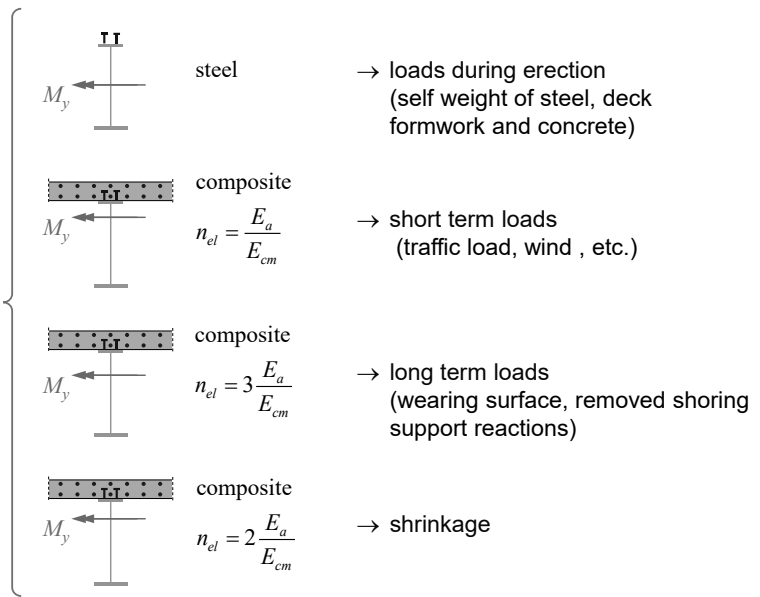

Structural analysis and design – Elastic design (EE, EER)

Elastic design (EE, EER)

Elastic stiffnesses

- On this and the following slide, the considered sections and modular ratios recommended by SIA 264 are summarised.

Intermediate supports / hogging moments
deck in tension, cracked concrete neglected

→ stiffness of tension chord or bare reinforcement (linear = simpler)

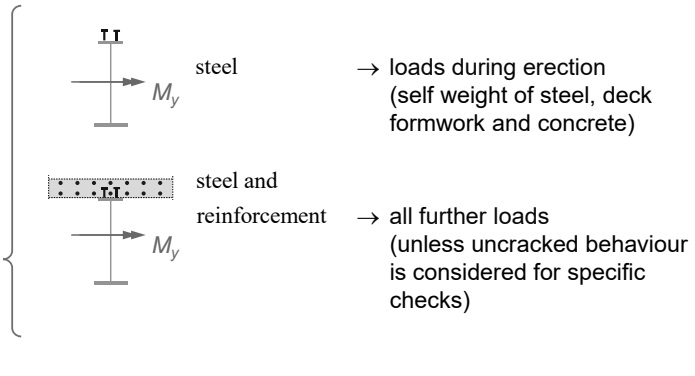

- In case of double composite action, concrete in compression (top or bottom slab) is considered with the appropriate modular ratio (see span)

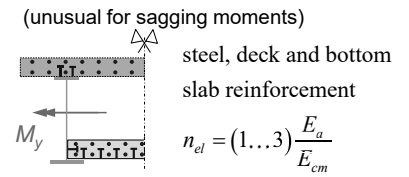
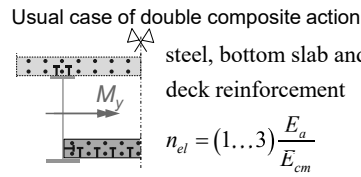

Superstructure / Girder bridges

Design and erection

Steel and steel-concrete composite girders

Structural analysis and design – Fatigue

Structural analysis and design – Specific aspects

Fatigue

- Fatigue is highly relevant in steel and composite bridges, as it often governs the design (plate thicknesses, details). Here, some basic aspects are discussed; for more details, see lectures Stahlbau
- Fatigue is particularly important in the design of railway bridges, and must be considered in detail already in conceptual design. It is also important when assessing existing railway bridges, which are typically older than road bridges (network built earlier), e.g. photo (built 1859)
- Fatigue safety is verified for nominal stress ranges caused by the fatigue loads. However, additional effects (often not accounted for in structural analysis, such as imposed or restrained deformations, secondary elements or inadequate welding (visible defects or invisible residual stresses) may cause stresses that can be even more critical
 - consider fatigue in conceptual design
 - select appropriate details
 - ensure proper execution (welding)

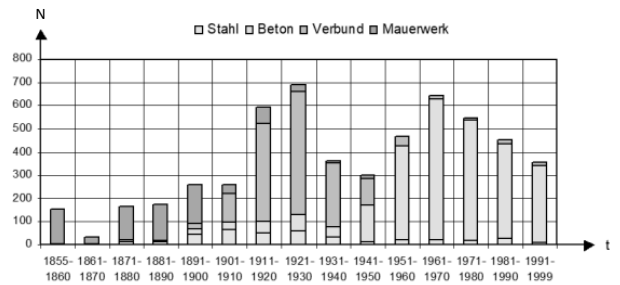

Photo: Rheinbrücke Koblenz, 1859 © Georg Aerni

Plot: Herbert Friedl, "Übersicht Portfolio SBB, Ingenieurbau," Bern, 09.12.2019

Notes:

AASHTO LRFD Bridge Design Specifications use the term "Distortion-Induced Fatigue" to describe *fatigue effects due to secondary stresses not normally quantified in the typical analysis of a bridge*. These effects are addressed through specific detailing rules throughout the Specifications, with the objective to *provide load paths that are sufficient to transmit all intended and unintended forces and preclude the development of significant secondary stresses that could induce fatigue crack growth*.

Structural analysis and design – Specific aspects

Fatigue – Case Study

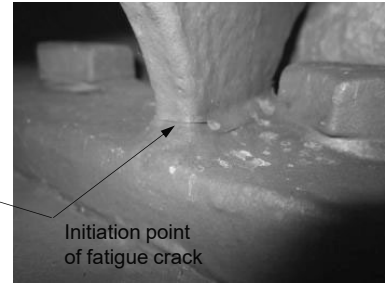
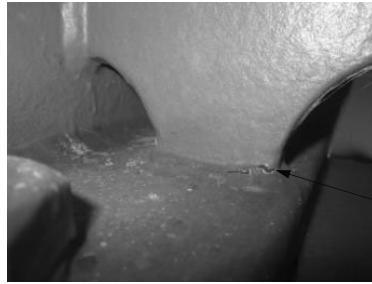

Initiation point of fatigue crack

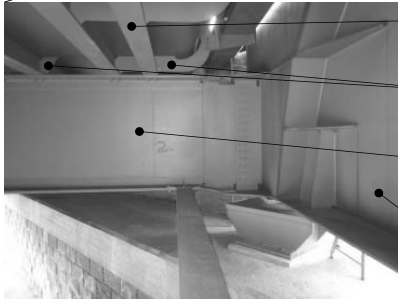

Deck Stringers
(Sek. Längsträger)

Stiffeners / Ribs
(Querrippen)

Floor Beam
(Querträger)

Main Girder
(Hauptträger)

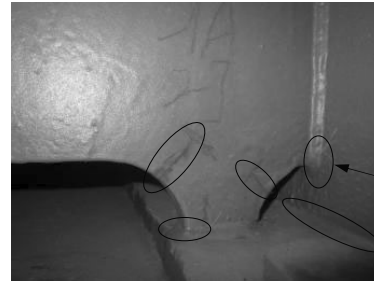

Observed fatigue cracks at welded stiffeners
(Coating impedes crack detection by naked eye)

Photos:

Overview: Linthlanalbrücke SBB, 1967, © Georg Aerni

Details: Ann Schumacher @ *dsp Ingenieure & Planer AG*

Structural analysis and design – Specific aspects

Fatigue

- The fatigue resistance of a specific detail depends on the stress range it is subjected to, and on its geometry
- A continuous stress flow is favourable and enhances the fatigue life.
- On the other hand, stress concentrations are triggering fatigue cracks and are therefore decisive for the fatigue strength:
 - ... welds
 - ... bolt holes
 - ... changes in cross-section

Example of detail optimised for fatigue strength force flow (rounding and grinding of gusset plate and weld to ensure continuous stress flow)

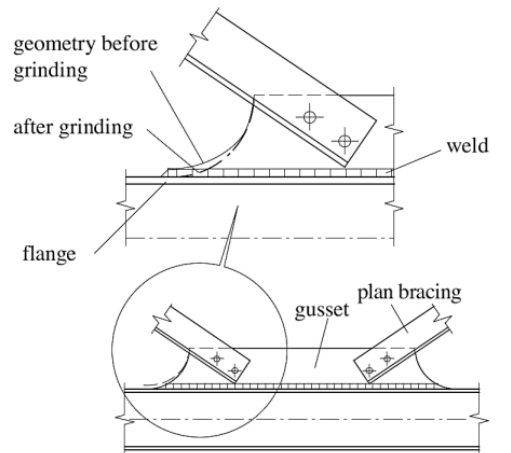

[Lebet and Hirt]

Figure: J.P. Lebet and M.A. Hirt, Steel bridges

Structural analysis and design – Specific aspects

Fatigue

- For the design of new structures, tables indicating the fatigue strength of typical details are used (SIA 263, Tables 22-26)
- These tables indicate detail categories, whose value are the fatigue resistance = stress range $\Delta\sigma_C$ for $2 \cdot 10^6$ cycles
- Typical details in bridge girders correspond to detail categories of $\Delta\sigma_C = 71, 80$ or 90 MPa (lower categories should be avoided by appropriate detailing)

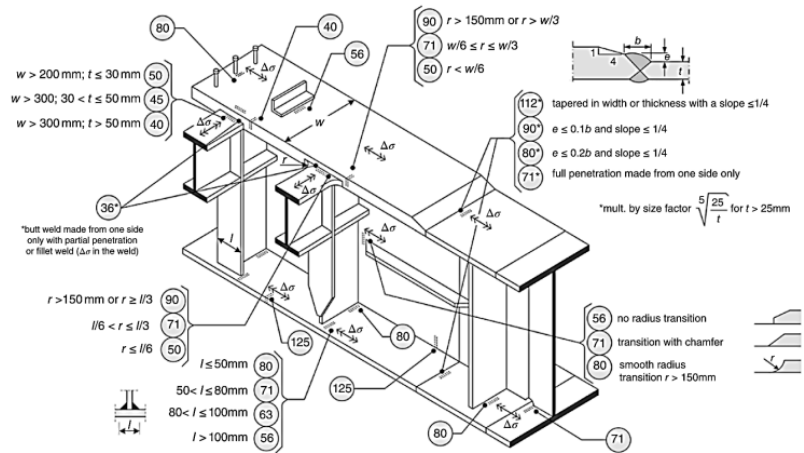

[Reis + Oliveiras]

Figure: Reis & Oliveras, Bridge design, 2019

Structural analysis and design – Specific aspects

Fatigue

- Since traffic loads do not cause equal stress ranges, damage accumulation should theoretically be accounted for to check the fatigue safety
- This is becoming common in existing structures (simulation of real traffic, so-called rainflow calculations), but is hardly ever done in design
- Rather, the nominal fatigue loads specified by codes are corrected using damage equivalent factors, ensuring that the resulting fatigue effect is representative of the expected accumulated fatigue damage
- The partial resistance factor for fatigue depends on the consequences of a damage and the possibilities for inspection (see SIA 263, Table 11)
- For damage equivalent factors, see relevant codes

Fatigue verification methodology for new structures (design)

1. Determine equivalent constant amplitude stress range ($2 \cdot 10^6$ cycles)
 $\Delta\sigma_{E2} = \lambda \cdot \Delta\sigma(Q_{fat})$ where $\lambda = \lambda_1 \cdot \lambda_2 \cdot \lambda_3 \cdot \lambda_4 \leq \lambda_{max} = 1.4$
2. Determine nominal fatigue resistance $\Delta\sigma_c$ of specific detail ($2 \cdot 10^6$ cycles)
3. Verify fatigue safety by comparing $\Delta\sigma_{E2}$ with $\Delta\sigma_c$

$$\gamma_{Ff} \cdot \Delta\sigma_{E2} \leq \frac{k_s \cdot \Delta\sigma_c}{\gamma_{Mf}}$$

- $\Delta\sigma_{E2}$: Equivalent constant amplitude stress range at $2 \cdot 10^6$ cycles
 $\Delta\sigma(Q_{fat})$: Stress range obtained using normalised fatigue load model
 λ : Damage equivalent factor
 λ_1 : Factor for the damage effect of traffic (influence length)
 λ_2 : Factor for the traffic volume
 λ_3 : Factor for the design life of the bridge
 λ_4 : Factor for the effect of several lanes / tracks
 $\Delta\sigma_c$: Fatigue resistance at $2 \cdot 10^6$ cycles for particular detail
 k_s : Reduction factor for size effect (usually $k_s = 1$)
 γ_{Mf} : Partial resistance factor for fatigue resistance $\gamma_{Mf} = 1.0 \dots 1.35$
 γ_{Ff} : Partial load factor for fatigue (usually $\gamma_{Ff} = 1$)

Superstructure / Girder bridges

Design and erection

Steel and steel-concrete composite girders

Structural analysis and design – Shear Connection

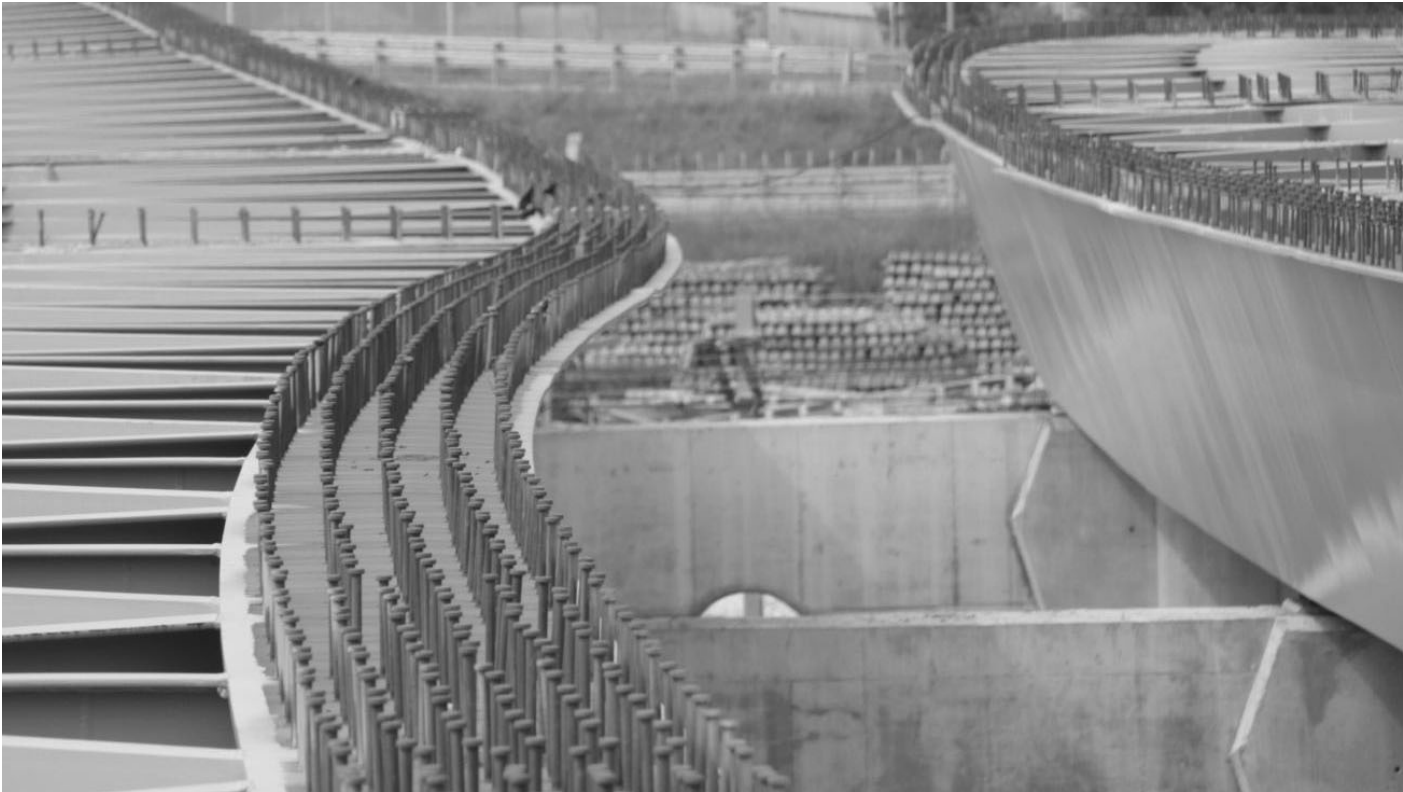
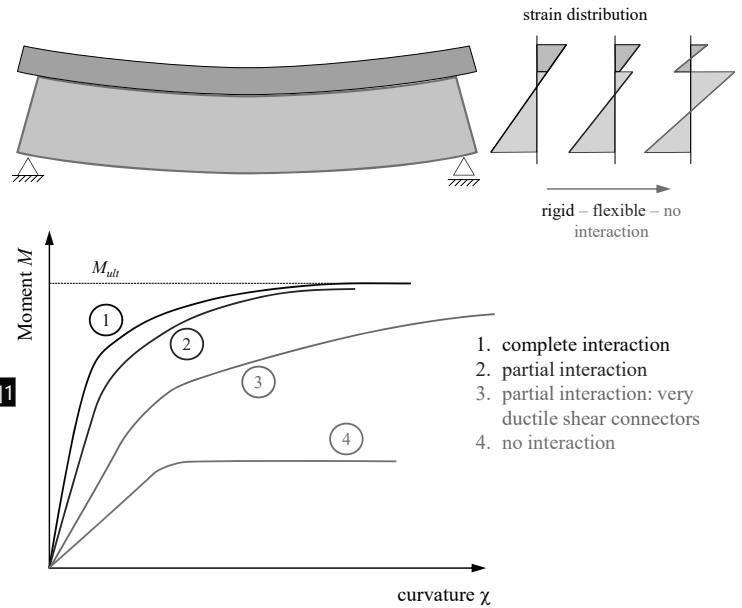

Photo: composite box girder bridge, Spain © Ar2V

Structural analysis and design – Shear Connection

General observations

- The shear connection between steel girders and concrete deck is essential for the behaviour of steel-concrete composite girders
- The shear connection can be classified by strength (capacity):
 - full shear connection
 - partial shear connection
- or by stiffness
 - rigid shear connection (full interaction)
 - flexible shear connection (partial interaction)
- In steel-concrete composite bridges, a full shear connection is provided. **GSA [2]1**
- Usually, ductile shear connectors are used, requiring deformations for their activation
 - flexible connection with partial interaction
 However, the flexibility is limited and commonly neglected when evaluating stresses and strains



Structural analysis and design – Shear Connection

Linear elastic behaviour – Homogeneous sections

- Assuming a uniform distribution of the shear stresses over the width b of the cross-section, the distribution of the vertical shear stresses τ_{zx} can be approximated in prismatic bars by the well-known formula illustrated in the figure
- Derivation see lectures (Mechanik and Baustatik):
 - consider infinitesimal element of length dx ,
 - horizontal cut at depth z_s
 - horizontal equilibrium on free body below z_s yields τ_{xz}
 - theorem of associated shear stresses: $\tau_{zx} = \tau_{xz}$
- A parabolic distribution of the shear stresses $\tau_{zx}(z)$ (resp. of the shear flow $b(z) \cdot \tau_{zx}(z)$ if b varies) is obtained.
- The resulting shear stresses are not meaningful in wide flanges (assumption of constant vertical shear stresses over width not reasonable)

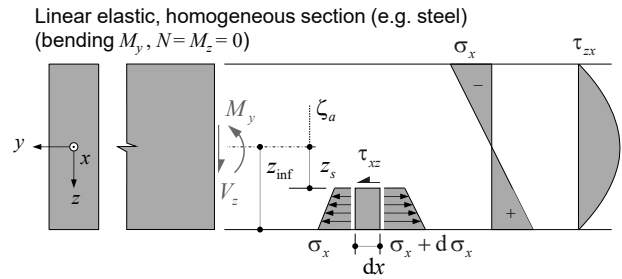

$$-\tau_{xz}(z_s) \cdot b(z_s) \cdot dx + \int_{z_s}^{-\text{inf}} d\sigma_x(z) \cdot b(z) dz = 0$$

$$\rightarrow \tau_{xz}(z_s) \cdot b(z_s) = \int_{z_s}^{-\text{inf}} \frac{d\sigma_x(z)}{dx} \cdot b(z) dz$$

$$\sigma_x = \frac{M_y}{I_y} z, \quad \frac{dM_y}{dx} = V_z \quad \rightarrow \quad \frac{d\sigma_x}{dx} = \frac{dM_y}{dx} \cdot \frac{z}{I_y} = \frac{V_z \cdot z}{I_y}$$

$$S(z_s) = \int_{z_s}^{-\text{inf}} z \cdot b(z) dz \quad \rightarrow \quad \tau_{xz}(z_s) = \frac{V_z \cdot S(z_s)}{b(z_s) \cdot I_y}$$

Structural analysis and design – Shear Connection

Linear elastic behaviour – Composite sections

- Using transformed section properties (ideelle Querschnittswerte, subscript "i")

$$A_i = \int \frac{dA}{n}, \quad \zeta_c = \frac{\int \zeta \cdot \frac{dA}{n}}{A_i}, \quad I_{yi} = \int z^2 \cdot \frac{dA}{n}$$

the shear stresses in composite sections consisting of materials with different moduli of elasticity or even cracked over a part of the depth can be treated accordingly, using the modular ratio

$$n = n(y, z) = \frac{E_a}{E(y, z)}$$

- In a cracked concrete section (see figure), the shear stresses in the cracked region can only change at the reinforcing bar layers (zero tensile stresses in concrete)
 - τ_{zx} (resp. $b(z) \cdot \tau_{zx}(z)$) parabolic over depth c of the compression zone, constant below until reinforcement

Linear elastic, cracked reinforced concrete section (bending $M_y, N = M_z = 0$)

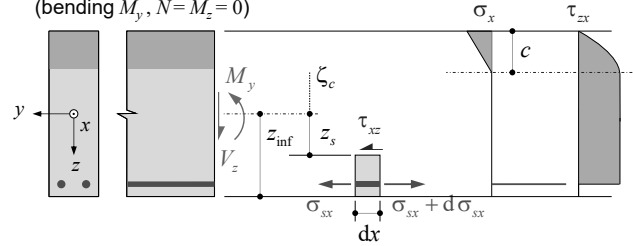

$$-\tau_{xz}(z_s) \cdot b(z_s) \cdot dx = \int_{z_s}^{z_{\text{inf}}} \int_{b(z)} d\sigma_x(y, z) \cdot dA = 0$$

$$\rightarrow \tau_{xz}(z_s) \cdot b(z_s) = \int_{z_s}^{z_{\text{inf}}} \int_{b(z)} \frac{d\sigma_x(y, z)}{dx} \cdot dA$$

$$\sigma_x = \frac{1}{n} \frac{M_y}{I_{yi}} z, \quad \frac{dM_y}{dx} = V_z \quad \rightarrow \quad \frac{d\sigma_x}{dx} = \frac{1}{n} \frac{dM_y}{dx} \cdot \frac{z}{I_{yi}} = \frac{1}{n} \frac{V_z \cdot z}{I_{yi}}$$

$$S_i(z_s) = \int_{z_s}^{z_{\text{inf}}} \int_{b(z)} z \cdot \frac{dA}{n} \quad \rightarrow \quad \tau_{xz}(z_s) = \frac{V_z \cdot S_i(z_s)}{b(z_s) \cdot I_{yi}}$$

Note again that in composite bridge design, contrary to reinforced concrete analysis, steel is conventionally used as reference material, but the definition $n = E_a / E_c$ is maintained (i.e., $n > 1$). The transformed section properties (ideelle Querschnittswerte) A_i, I_{yi} etc. are referred to E_a , and concrete areas have to be **divided by n**: Axial stiffness "EA" = $E_a A_i$, bending stiffness "EI" = $E_a I_i$ etc. Consequently, $A_i = A_a + A_c / n$ (rather than $A_i = A_c + n A_s$ in reinforced concrete). Therefore, the modular ratio is referred to as "Reduktionszahl" (rather than "Wertigkeit" as in concrete) in the German version of EN 1994.

Structural analysis and design – Shear Connection

Linear elastic behaviour – Composite sections

- In T-beams, the shear stresses at the interface of deck and girder are of primary interest ($z_s =$ interface level)
- These are usually determined using the first moment of area S_{ci} of the deck (rather than the girder), i.e., integrating stresses from the top, rather than the bottom, see figure (results are the same, of course)
- Note that the upper equations (equilibrium) are valid for any material behaviour, while the lower ones imply linear elasticity and plane sections remaining plane (this applies as well to the previous slides, including homogeneous material)

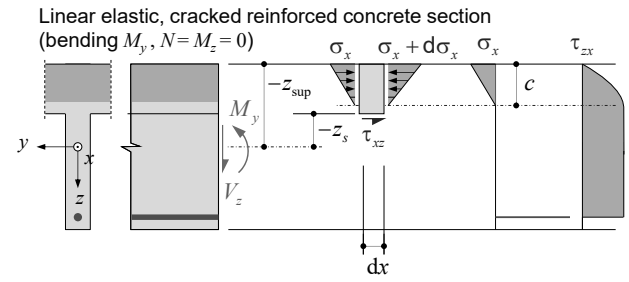

equilibrium, valid for any material behaviour

$$\begin{cases} -\tau_{xz}(z_s) \cdot b(z_s) \cdot dx = \int_{z_{sup}}^{z_s} \int_{b(z)} d\sigma_x(y, z) \cdot dA = 0 \\ \rightarrow \tau_{xz}(z_s) \cdot b(z_s) = \int_{z_{sup}}^{z_s} \int_{b(z)} \frac{d\sigma_x(y, z)}{dx} \cdot dA \end{cases}$$

valid only for linear elastic material (longitudinal stresses)

$$\begin{cases} \sigma_x = \frac{1}{n} \frac{M_y}{I_{yi}} z, \quad \frac{dM_y}{dx} = V_z \quad \rightarrow \quad \frac{d\sigma_x}{dx} = \frac{1}{n} \frac{dM_y}{dx} \cdot \frac{z}{I_{yi}} = \frac{1}{n} \frac{V_z \cdot z}{I_{yi}} \\ S_{ci}(z_s) = \int_{z_{sup}}^{z_s} \int_{b(z)} z \cdot \frac{dA}{n} \quad \rightarrow \quad \tau_{xz}(z_s) = \frac{V_z \cdot S_{ci}(z_s)}{b(z_s) \cdot I_{yi}} \end{cases}$$

Structural analysis and design – Shear Connection

General behaviour – Composite sections

- Independently of the material behaviour, the longitudinal shear stresses must introduce the difference of the flange normal force N_f , i.e.

$$\tau_{xz}(z_s) \cdot b(z_s) = \int_{z_{\text{sup}}}^{z_s} \int_{b(z)} \frac{d\sigma_x(y,z)}{dx} \cdot dA = \frac{dN_f}{dx}$$

(for $z_s =$ interface web-flange)

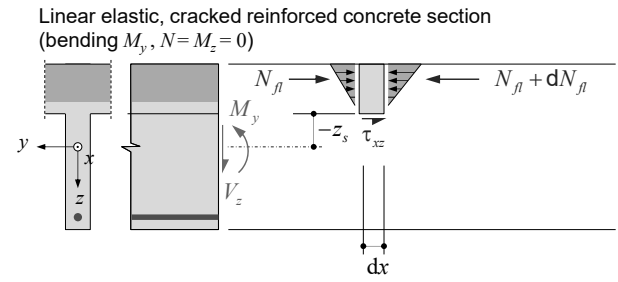

$$\left. \begin{array}{l} \text{equilibrium, valid for} \\ \text{any material behaviour} \end{array} \right\} \begin{cases} -\tau_{xz}(z_s) \cdot b(z_s) \cdot dx = \int_{z_{\text{sup}}}^{z_s} \int_{b(z)} d\sigma_x(y,z) \cdot dA = 0 \\ \rightarrow \tau_{xz}(z_s) \cdot b(z_s) = \int_{z_{\text{sup}}}^{z_s} \int_{b(z)} \frac{d\sigma_x(y,z)}{dx} \cdot dA \end{cases}$$

$$\left. \begin{array}{l} \text{valid only for linear} \\ \text{elastic material} \\ \text{(longitudinal stresses)} \end{array} \right\} \begin{cases} \sigma_x = \frac{1}{n} \frac{M_y}{I_{yi}} z, \quad \frac{dM_y}{dx} = V_z \quad \rightarrow \quad \frac{d\sigma_x}{dx} = \frac{1}{n} \frac{dM_y}{dx} \cdot \frac{z}{I_{yi}} = \frac{1}{n} \frac{V_z \cdot z}{I_{yi}} \\ S_{ei}(z_s) = \int_{z_{\text{sup}}}^{z_s} \int_{b(z)} z \cdot \frac{dA}{n} \quad \rightarrow \quad \tau_{xz}(z_s) = \frac{V_z \cdot S_{ei}(z_s)}{b(z_s) \cdot I_{yi}} \end{cases}$$

Structural analysis and design – Shear Connection

Linear elastic behaviour – Steel-concrete composite sections

- Accordingly, in steel-concrete composite sections, the longitudinal shear at the interface between deck and steel girder is decisive
- The relevant shear stresses (resp. shear forces per unit length) to be transferred along the interface are thus obtained using the first moment of area of the deck (without flange of steel girder!), i.e.

$$\tau_{xz}(z_s) \cdot b(z_s) = \frac{V_z \cdot S_{ci}(z_s)}{I_{yi}} \quad \left(S_{ci}(z_s) = \int_{z_{sup}}^{z_s} \int_{b(z)} z \cdot \frac{dA}{n} \right)$$

- The contribution of the deck reinforcement is commonly included in the values “c” of the concrete deck (“c” = reinforced concrete), and often neglected for positive bending (reinforcement in compression)

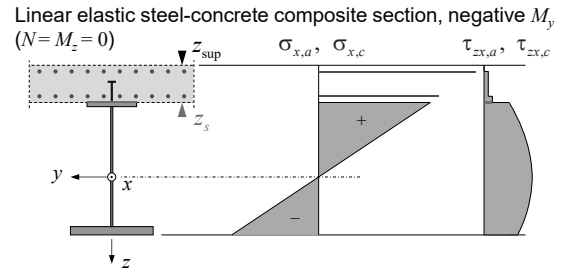
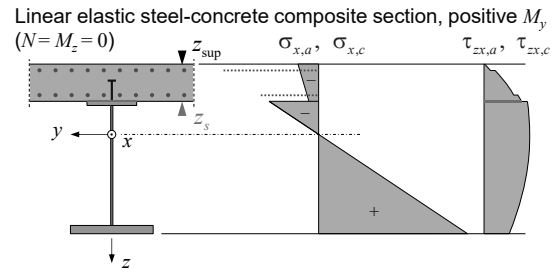

Structural analysis and design – Shear Connection

Linear elastic behaviour – Steel-concrete composite sections

- Again, the equation

$$\tau_{xz}(z_s) \cdot b(z_s) = \frac{V_z \cdot S_{ci}(z_s)}{I_{yi}} \quad \left(S_{ci}(z_s) = \int_{z_{sup}}^{z_s} \int_{b(z)} z \cdot \frac{dA}{n} \right)$$

only applies for linear elastic behaviour

- if bending resistances exceeding the elastic resistance $M_{el,Rd}$ are activated (e.g. Method EP, utilisation of full plastic resistance $M_{pl,Rd}$), application of the above equation may be unsafe

Linear elastic steel-concrete composite section, positive M_y
($N = M_z = 0$)

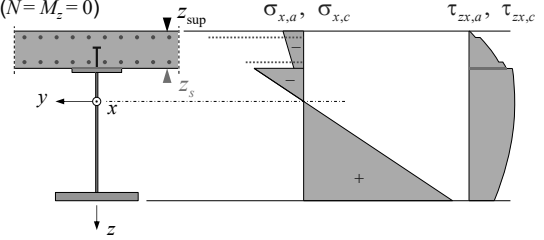

Linear elastic steel-concrete composite section, negative M_y
($N = M_z = 0$)

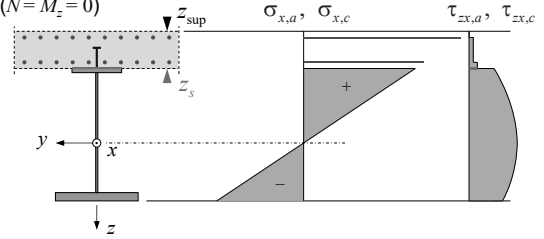

Structural analysis and design – Shear Connection

General behaviour – Composite sections

- However, independently of the material behaviour, the integral of the interface shear stresses must introduce the increase of the deck normal force N_c , i.e.

$$\tau_{xz}(z_s) \cdot b(z_s) = \int_{z_{sup}}^{z_s} \int_{b(z)} \frac{d\sigma_x(y,z)}{dx} \cdot dA = \frac{dN_c}{dx}$$

(for z_s = interface steel beam-concrete deck)

- If the infinitesimal length dx is substituted by a finite length Δx , this approach is referred to as plastic design of the shear connection, as it requires redistribution of the longitudinal shear forces over Δx
- This is admissible if ductile connectors (headed studs) are used. Since plastic design of the shear connection is also simpler in most cases
 - plastic design of shear connection preferred for structural safety (except for fatigue verifications), unless brittle connectors are used

Linear elastic steel-concrete composite section, positive M_y
($N = M_z = 0$)

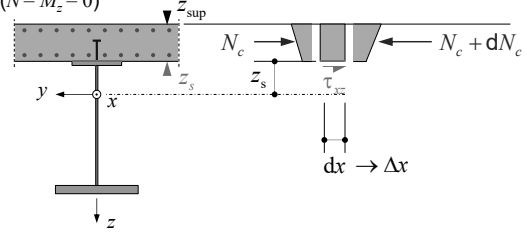

Linear elastic steel-concrete composite section, negative M_y
($N = M_z = 0$)

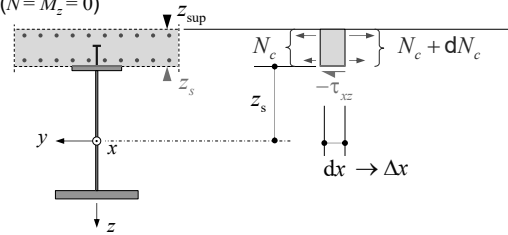

Structural analysis and design – Shear Connection

Elastic design of shear connection

- Elastic design of the shear connection is suitable for design situations resp. regions of the girder where the composite section remains elastic
 - fatigue verifications
 - elastic design (EE, EER)
 - elastic-plastic design (EP) outside regions where the elastic resistance $M_{el,Rd}$ is exceeded
- As derived on the previous slides, the longitudinal shear force per unit length v_{el} is proportional to the vertical shear force V
- The section properties are commonly determined considering uncracked concrete (and neglecting the reinforcement), even in cracked areas (see notes). Therefore, rather than determining the transformed moment of area S_{ci} , one may simply use S_c of the gross concrete section, divided by n_{el} .

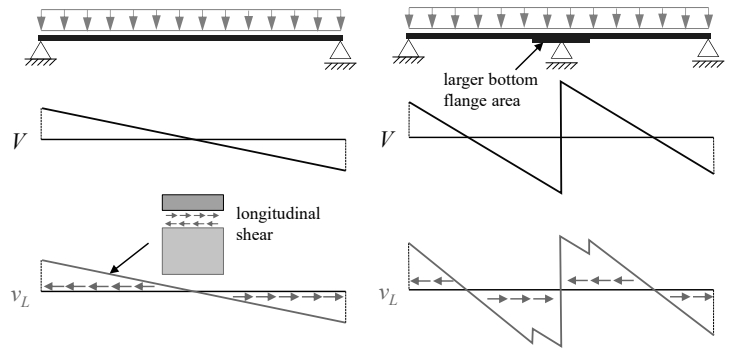

$$v_{L,Ed} = \tau_{xz} \cdot b = \frac{V_{Ed} \cdot S_{ci}}{I_b} \approx \frac{V_{Ed} \cdot S_c}{I_b \cdot n_{el}} \left(S_{ci} = \iint z \frac{dA}{n} \approx \frac{S_c}{n} = \frac{1}{n_{el}} \iint z dA \right)$$

- V : Vertical shear force after steel to concrete connection is established
- S_{ci} : First moment of area of the deck relative to the neutral axis of the composite section (with subscript i: transformed section)
- I_b : Second moment of area of the composite section, calculated with the appropriate modular ratio n_{el}
- n_{el} : Elastic modular ratio $(1 \dots 3) \cdot E_a / E_{cm}$

To simplify calculations, even in areas where the concrete is cracked, the section properties are calculated for the uncracked section. If only the reinforcements in tension were considered in these areas, the longitudinal shear would be underestimated, since the contribution of the concrete between the cracks (*tension stiffening*) is neglected. Therefore, estimating the longitudinal shear in cracked areas by considering the uncracked concrete is on the safe side.

Structural analysis and design – Shear Connection

Elastic design of shear connection

- Since different modular ratios n_{el} apply for short-term and long-term loads, the design value of the longitudinal shear in each section is the sum of a number of cases j
- If headed studs with a design shear resistance P_{Rd} per stud are used (determination of P_{Rd} see behind), the required number of studs per unit length of the girder is obtained by dividing the longitudinal shear force by P_{Rd}
- To avoid excessive slip, the resistance of the shear connectors has to be reduced by 25% under certain conditions; the slide shows the condition of EN1994-2. For further details, see headed studs

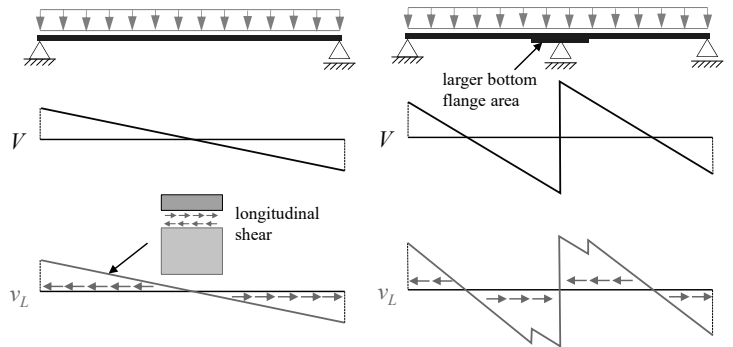

$$v_{L,Ed} = \sum_j v_{L,Ed,j} = \sum_i \frac{V_{Ed,i} S_{c,i}}{I_{b,i} n_{el,i}}$$

$$\frac{n_{v,el}}{e_L} \geq \frac{v_{L,Ed}}{P_{Rd}} \text{ and } v_{L,Ek} \frac{e_L}{n_{v,el}} \leq 0.75 P_{Rd} \left(\text{i.e. } \frac{n_{v,el}}{e_L} \geq \frac{v_{L,Ek}}{0.75 P_{Rd}} \right)$$

$n_{v,el}$: number of shear connectors

e_L : longitudinal spacing of connectors

P_{Rd} : design shear resistance of one shear connector (depending on elastic / plastic calculation of section, see behind)

Structural analysis and design – Shear Connection

Elastic design of shear connection

- The longitudinal shear force diagram must basically be enveloped by the provided resistance
- Commonly, it is tolerated that the design shear force $v_{L,Ed}$ exceeds the resistance $v_{L,Rd}$ by 10% at certain points, provided that the total resisting force in the corresponding zone is larger than the total design force

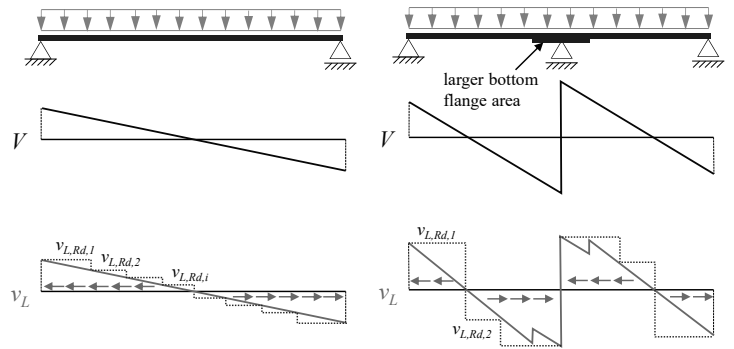

Structural analysis and design – Shear Connection

Elastic design of shear connection

- As illustrated in the figure and mentioned previously, the longitudinal shear forces

$$v_{L,Ed} = \tau_{xz} \cdot b = \frac{V_{Ed} \cdot S_{ci}}{I_b} \approx \frac{V_{Ed} \cdot S_c}{I_b \cdot n_{el}}$$

may be unsafe if bending resistances exceeding the elastic resistance $M_{el,Rd}$ are activated (derivation of the equation implies a linear elastic distribution of the cross-section)

- If an elastic design of the shear connection is carried out, but a bending resistance $M_{Rd} > M_{el,Rd}$ is used (Method EP), it must be verified that the shear connection can transfer the normal force increase $N_{c,d} - N_{c,el}$ in the deck required for reaching M_{Rd} over the length x_{pl} , i.e.

$$n_{v,pl} = \frac{N_{c,d} - N_{c,el}}{x_{pl} \cdot P_{Rd}}$$

- This is particularly relevant in unpropped girders, where the deck normal force $N_{c,el}$ under $M_{el,Rd}$ is considerably lower than at $M_{pl,Rd}$ (concrete weight is carried fully by the steel section without causing any contribution to $N_{c,el}$)

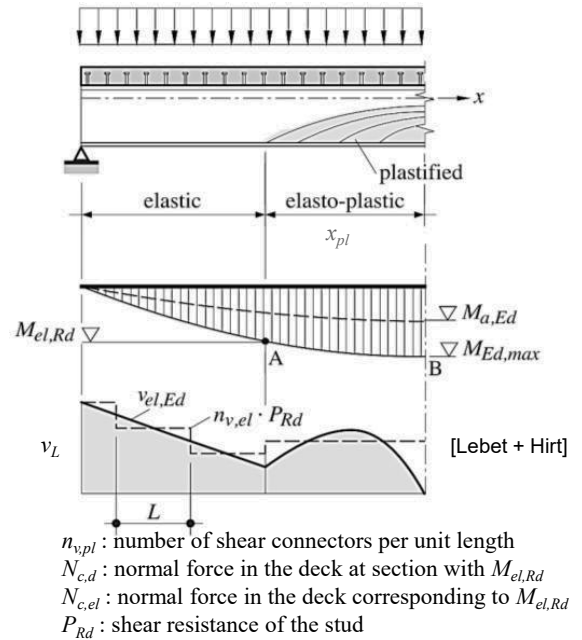

This approach corresponds to a plastic design of the shear connectors over the length AB → next slides

Structural analysis and design – Shear Connection

Plastic design of shear connection

- When considering two sections of a composite girder, the shear connection must transfer the difference of the deck normal force N_c between the two sections by equilibrium (see section on general behaviour)

$$\int_{\Delta x} v_L(x) \cdot dx = \Delta N_c = N_c(x + \Delta x) - N_c(x)$$

- valid for any material behaviour
- applies to non-prismatic sections as well (e.g. additional concrete bottom slab over support)

- If ductile shear connectors are used (such as headed studs), a uniform value of the longitudinal shear force may be assumed over reasonable lengths

→ required longitudinal shear resistance H_v over Δx :

$$\int_{\Delta x} v_L(x) \cdot dx = v_L \cdot \Delta x = H_v \geq |\Delta N_c|$$

→ plastic design of shear connection

Linear elastic steel-concrete composite section, positive M_y
($N = M_z = 0$)

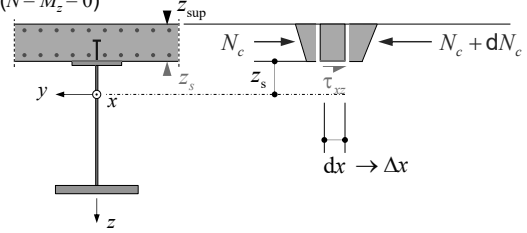

Longitudinal shear between two sections at finite distance

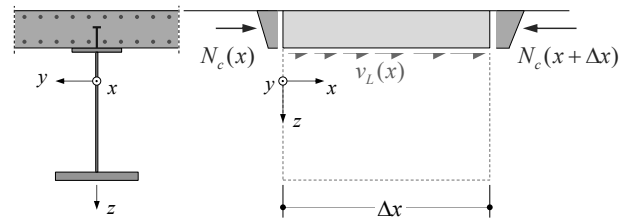

Structural analysis and design – Shear Connection

Plastic design of shear connection

- On the following slides, plastic design of the shear connection is outlined using plastic bending resistances (Method EP), assuming that the full cross-sectional resistance needs to be activated (see notes) but neglecting deck reinforcement in compression
- While codes often require an elastic design of the shear connection when using Methods EE(R), a plastic design – using suitably reduced intervals Δx – is still possible (using elastic stress distributions)
- In the example, intervals are chosen such that they are bounded by the points of zero shear (max/min bending moments) to avoid shear reversals per interval, and additionally at zero moment points to get a more refined distribution of shear connectors (without any additional computational effort)
- Design of the shear connection starts at end support A (end of deck, $N_{c,A}=0$), considering the interval AB. The shear connection between A and midspan (B) must thus transfer the compression in the deck at midspan $N_{c,B}$

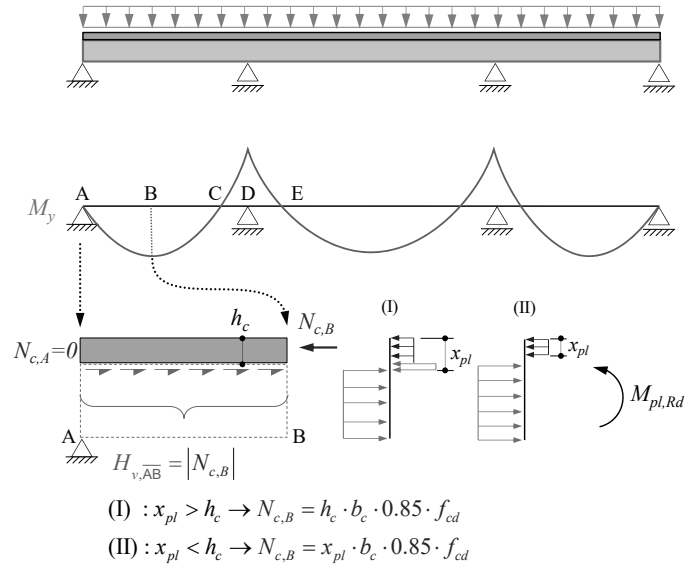

Providing a shear connection for the full plastic bending resistances may require an excessive number of connectors in cases where the full moment capacity (particularly regarding full activation of the concrete deck or bottom slab in case of double composite action in compression) is not required for bending resistance. In such cases, many designers merely provide a connection to activate the required bending resistance.

Structural analysis and design – Shear Connection

Plastic design of shear connection

(example continued)

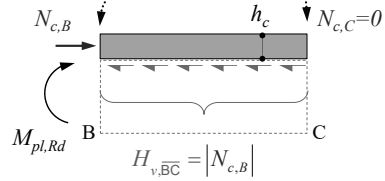
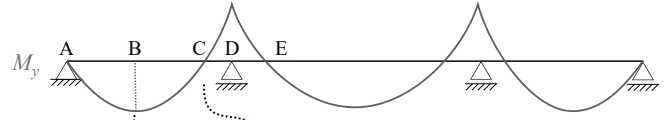
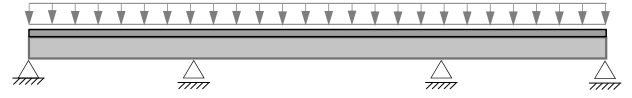

- Proceeding to the interval BC, where C = zero moment point (thus $N_{c,C}=0$), the shear connection between B and C must thus also transfer the compression in the deck at midspan $N_{c,B}$

(with opposite sign than in interval AB, which is irrelevant for the shear studs but not for the longitudinal shear in the slab)

$$(I) : x_{pl} > h_c \rightarrow N_{c,B} = h_c \cdot b_c \cdot 0.85 \cdot f_{cd}$$

$$(II) : x_{pl} < h_c \rightarrow N_{c,B} = x_{pl} \cdot b_c \cdot 0.85 \cdot f_{cd}$$

Structural analysis and design – Shear Connection

Plastic design of shear connection

(example continued)

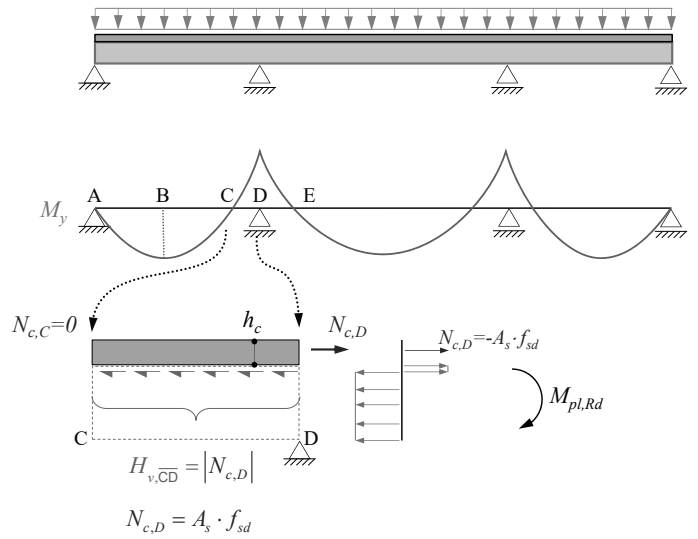

- In the subsequent interval CD, between zero moment point C ($N_{c,C}=0$) and intermediate support D, the shear connection must transfer the tension in the deck over the support $N_{c,D}$

Structural analysis and design – Shear Connection

Plastic design of shear connection

(example continued)

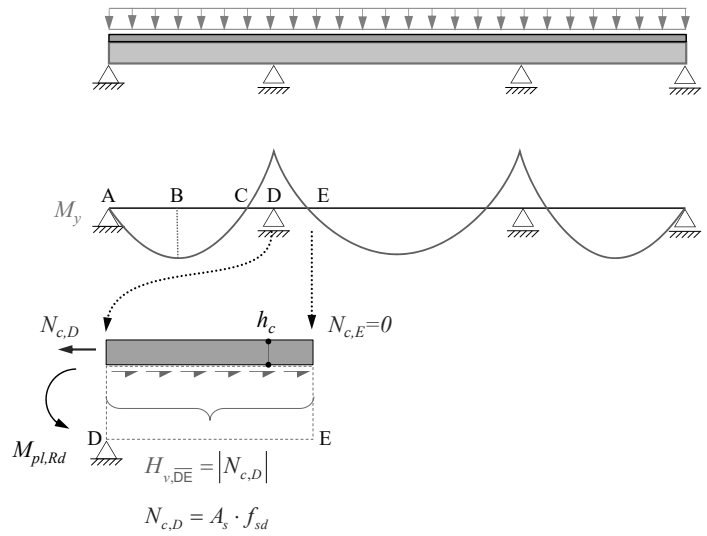

- In the interval DE, between the intermediate support D and the zero moment point E in the inner span ($N_{c,E}=0$), the shear connection must also transfer $N_{c,D}$

(with opposite sign than in interval CD, which is irrelevant for the shear studs but not for the longitudinal shear in the slab)

Structural analysis and design – Shear Connection

Plastic design of shear connection

- The total number of shear connectors per interval is obtained simply by dividing the longitudinal shear force per interval by the resistance per connector, e.g. for AB:

$$n_{v,pl,AB} = \frac{H_{v,AB}}{P_{Rd}}$$

- Where appropriate, these connectors should be distributed roughly according to the linear elastic shear force diagram over the interval (illustrated for the end span AB, see notes)
 - adequate behaviour in SLS
 - less additional connectors required by subsequent fatigue verification (elastic calculation)
- The intervals used in the example should be further subdivided at
 - large concentrated forces (e.g. prestressing, truss node), see next slide
 - substantial changes in cross-section (e.g. bottom slab end in double composite action)

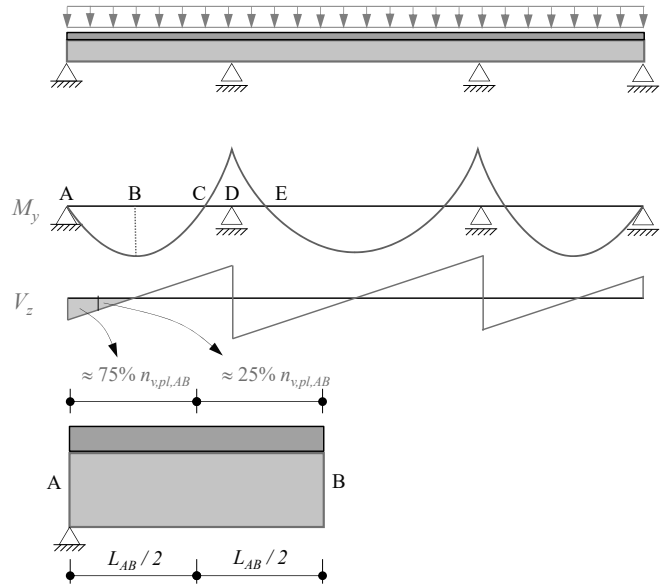

In order to ensure adequate serviceability behaviour (SLS) and avoid the risk of failure by fatigue of the connectors and their welds, the total number of the connectors of each segment $n_{v,pl}$ are distributed over it, in two or three zones, in proportion to the elastic diagram of the longitudinal shear acting on the composite girder, i.e. proportional to the shear diagram.

Structural analysis and design – Shear Connection

Longitudinal shear forces due to (concentrated) horizontal loads

- Horizontal loads and imposed deformations, applied to the deck or steel section, cause longitudinal shear forces (transfer to composite section)
- This applies in cases such as:
 - prestressing (anchor forces P)
 - shrinkage or temperature difference between concrete deck and steel beam
 - horizontal forces applied e.g. through truss nodes (difference in normal force ΔN)
 - bending moments applied e.g. through non-ideal truss nodes (difference in bending moment ΔM)
 - concentrated longitudinal shear forces resulting from sudden changes in the dimensions of the cross-section

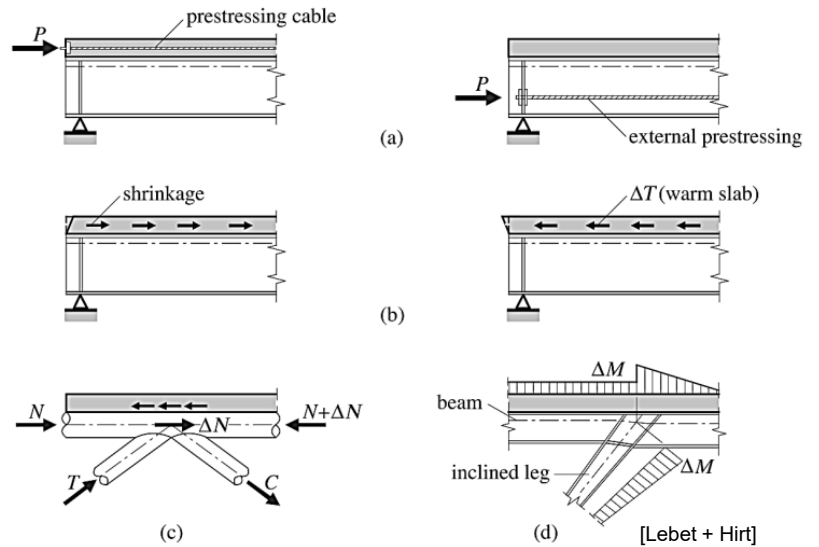

Illustrations adapted from J.P. Lebet and M.A. Hirt, Steel bridges

Structural analysis and design – Shear Connection

Longitudinal shear forces due to (concentrated) horizontal loads

- The part of the horizontal load that needs to be transferred can be determined from equilibrium (apply eccentric horizontal load ΔN to composite section, difference of deck normal force N_c in deck to applied load $\Delta N - N_c$ needs to be transferred)
- For structural safety (ULS STR), if ductile shear connectors are provided, it may be assumed that the concentrated force F_{Ed} is introduced uniformly over the length L_v

$$v_{Ed} = \frac{F_{Ed}}{L_v}$$

- The length L_v should be chosen as short as possible (concentrate shear connectors), and not exceed about half the effective width of the deck on either side of the load (see figure)
- If such loads are relevant for fatigue (e.g. truss nodes), the load distribution should be investigated in more detail (or conservative values adopted in the fatigue verification)

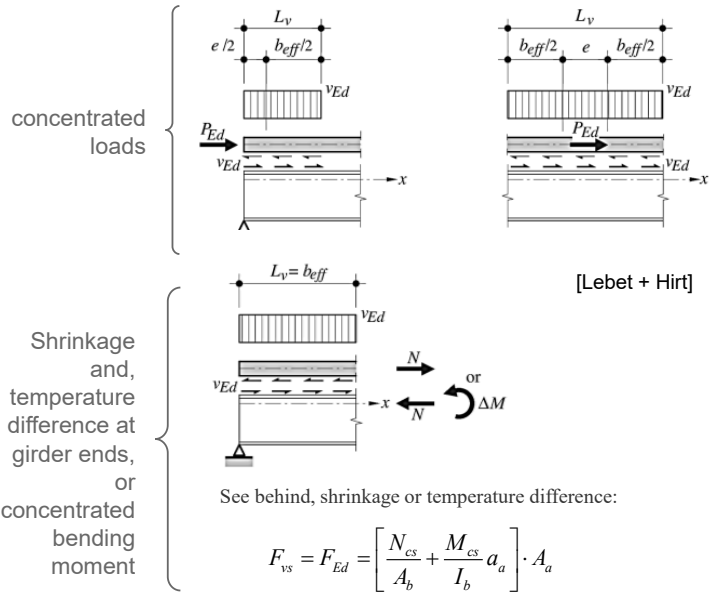

For more details follow J.P. Lebet and M.A. Hirt, Steel bridges.

Illustrations adapted from J.P. Lebet and M.A. Hirt, Steel bridges

Structural analysis and design – Shear Connection

Types of Shear Connectors

- Basically, there are many possibilities to establish a shear connection:
 - rigid connectors (brittle)
 - inclined hoops
 - perfobond ribs
 - ...
 - semi-rigid or flexible connectors (ductile)
 - angles, channels, T,... steel profiles (without stiffeners)
 - headed studs (Kopfbolzendübel) (aka Nelson studs)
 - ...
- In modern steel-composite bridges, arc welded headed studs are used in most cases (ductile, economic, practical for placement of reinforcement, etc.)

→ video

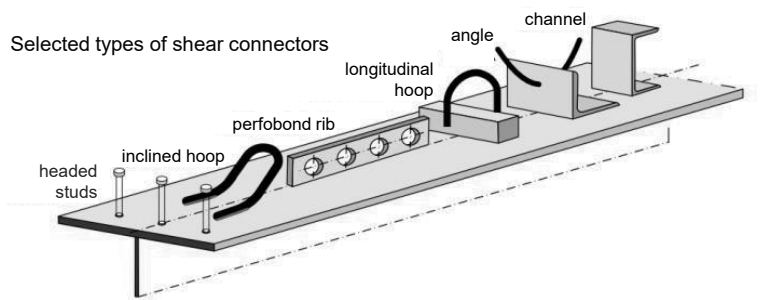

Typical headed studs (Kopfbolzendübel)

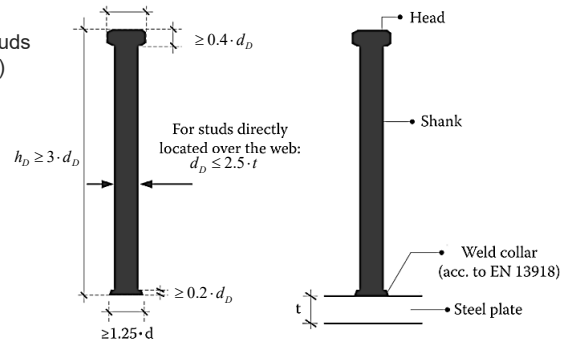

Illustration adapted from Reis Oliveiras, Bridge Design / I. Vayas and A. Iliopoulos, Design of steel-concrete composite bridges to Eurocode

Structural analysis and design – Shear Connection

Resistance of headed studs

- Headed studs transfer “shear” by a combination of bending and tension, resulting in a complex behaviour
 - ductile response with relatively large deformations
 - resistances determined by testing
- Based on the experimental studies, the “shear strength” of headed studs P_{Rd} is limited by
 - ... failure of the stud shank at $P_{D,Rd}$ or
 - ... crushing of the concrete at $P_{c,Rd}$, i.e.
 - $P_{Rd} = \min \{P_{c,Rd}, P_{D,Rd}\}$
- If tensile forces $F_t > 0.1 \cdot P_{Rd}$ act in the direction of the stud (e.g. introduction of transverse bending moment to web), the shear resistance should be determined from representative tests (usually not critical)
- Additional provisions to avoid excessive slip apply:
 - SIA 263: Reduce $P_{c,Rd}$ by 25% if elastic resistance is used (Methods EE, EER)
 - EN1994-2: Shear force per stud must not exceed $0.75 \cdot P_{Rd}$ under characteristic loads

Concrete crushing

$$P_{c,Rd} = \frac{0.29d_D^2}{\gamma_v} \sqrt{f_{ck} \cdot E_{cm}}$$

Failure of the stud shank

$$P_{D,Rd} = \frac{0.8f_{u,D}}{\gamma_v} \cdot \frac{\pi d_D^2}{4}$$

d_D : diameter of the stud shank

f_{ck} : characteristic value of concrete cylinder strength

E_{cm} : mean value of concrete elastic modulus

$$E_{cm} = 10'000 \sqrt[3]{f_{ck} + 8} \text{ in N/mm}^2$$

$f_{u,D}$: ultimate tensile resistance of the stud steel (typically 450 MPa)

γ_v : resistance factor for the shear connection ($\gamma_v = 1.25$)

Design values of P_{Rd} per stud [kN] (plastic calculation, $f_{u,D} = 450$ MPa)

Diameter of the stud shank d_D	Plastic Calculation		
	Concrete C20/25	Concrete C25/30	Concrete > C30/37
19 mm	65	75	82
22 mm	88	101	109
25 mm	113	130	141

avoid (unusual)

Table adapted from J.P. Lebet and M.A. Hirt, Steel bridges

Structural analysis and design – Shear Connection

Fatigue resistance of headed studs

The following fatigue verifications are required for plates with welded studs:

- Studs welded to flange in compression
 - ... fatigue of stud weld
- Studs welded to flange in tension
 - ... fatigue of stud weld
 - ... fatigue of steel plate
 - ... interaction of stud shear and flange tension
- A partial resistance factor of $\gamma_{Mf} = 1.15$ for fatigue is commonly used for shear connectors although the detail cannot be inspected (assumption: a fatigue crack would not lead to significant damage to a structure, as many studs are provided)

Studs welded to flange in compression

$$\Delta\tau_{E2} \leq \frac{\Delta\tau_C}{\gamma_{Mf}}$$

Studs welded to flange in tension

$$\Delta\tau_{E2} \leq \frac{\Delta\tau_C}{\gamma_{Mf}} \quad \Delta\sigma_{E2} \leq \frac{\Delta\sigma_C}{\gamma_{Mf}}$$

$$\frac{\Delta\sigma_{E2}}{\Delta\sigma_C/\gamma_{Mf}} + \frac{\Delta\tau_{E2}}{\Delta\tau_C/\gamma_{Mf}} \leq 1.3$$

$\Delta\tau_{E2}$: Equivalent constant amplitude stress range at $2 \cdot 10^6$ cycles for nominal shear stresses in stud shank

$\Delta\sigma_{E2}$: Equivalent constant amplitude stress range at $2 \cdot 10^6$ cycles for tensile stresses in steel plate to which stud is welded

$\Delta\tau_C$: Fatigue resistance at $2 \cdot 10^6$ cycles for particular detail K1
GSA1
(shear studs: $\Delta\tau_C = 90$ MPa)

$\Delta\sigma_C$: Fatigue resistance at $2 \cdot 10^6$ cycles for particular detail (plate in tension with welded shear studs: $\Delta\sigma_C = 80$ MPa)

γ_{Mf} : Partial resistance factor for fatigue resistance of the shear connection factor for the shear connection ($\gamma_{Mf} = 1.15$)

λ : Damage equivalent factor

Structural analysis and design – Shear Connection

Detailing of shear connection

- The shear connection needs to be carefully detailed, particularly regarding space requirements (avoid conflicts of studs and deck reinforcement)
- Figures (a)-(c) illustrate selected provisions of EN1994-2
- Further details see SIA 264 and EN1994-2,

(a) Longitudinal spacing e_L

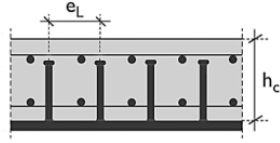

$$5 \cdot d \leq e_L \leq \min \{4 \cdot h_c, 800 \text{ mm}\}$$

(c) Maximum spacings to stabilise slender plates (→ compression flange Class 1 or 2 fully active = Class 1 or 2)

$$e_L \leq 22 \cdot \varepsilon \cdot t_f \quad \left(\begin{array}{l} \text{solid slab in contact} \\ \text{over its full surface} \end{array} \right)$$

$$e_L \leq 15 \cdot \varepsilon \cdot t_f \quad (\text{otherwise})$$

$$e_D \leq 9 \cdot \varepsilon \cdot t_f$$

$$\text{with } \varepsilon = \sqrt{235 / f_y}$$

Composite plates

- If a concrete deck is cast on a full-width steel plate (top flange of closed steel box, “composite plate”, figure (d)), the shear connectors should be concentrated near the webs
- In fatigue design, the fact that the studs close to the web resist higher forces needs to be accounted for (see EN1994-2, Section 9 for details)

(b) Transverse spacing e_T and edge distance e_D

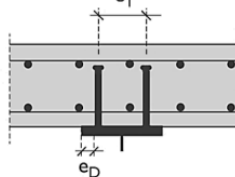

$$e_D \geq 25 \text{ mm} \quad (\text{solid slabs})$$

$$e_D \geq 2.5 \cdot d \quad (\text{otherwise})$$

$$e_T \geq 4 \cdot d$$

(d) Shear connectors on wide plate (closed steel box with concrete deck)

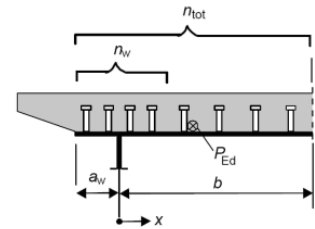

Illustration (d) adapted from I. Vayas and A. Iliopoulos, “Design of steel-concrete composite bridges to Eurocode,” CRC Press, 2013.

Structural analysis and design – Shear Connection

Longitudinal shear in the concrete slab

- The shear connectors provide the transfer of the longitudinal shear forces from the steel beams to the concrete deck
- The further load transfer in the deck needs to be ensured by the dimensioning of the concrete slab
- The local load introduction (Sections B-B and C-C in the figure) is checked by considering a local truss model, activating all the reinforcement A_s crossed by the studs and concrete dimensions corresponding to the section length L_c (see table for and L_c), usually using an inclination of 45°

Overall force flow

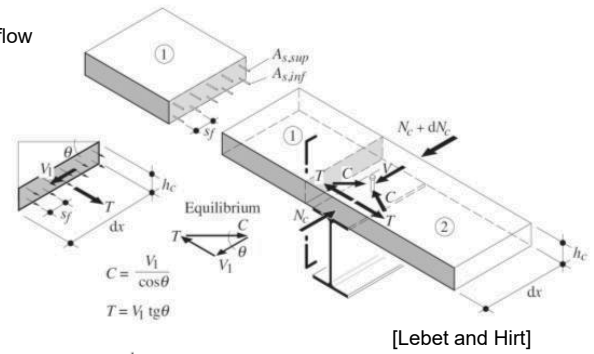

Local shear force introduction from studs to slab

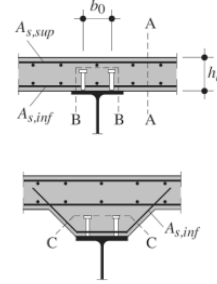

Type	A_s	L_c
A-A	$A_{s,inf} + A_{s,sup}$	h_c
B-B	$2A_{s,inf}$	$2h_D + b_0 + d_D$
C-C	$2A_{s,inf}$	$2h_D + b_0 + d_D$

[Lebet and Hirt]

Illustrations and table adapted from J.P. Lebet and M.A. Hirt, Steel bridges

Structural analysis and design – Shear Connection

Longitudinal shear in the concrete slab

- The further load distribution in the deck (Section A-A on previous slide) is analogous to that in the flange of a concrete T-beam

→ stress field or strut-and-tie model design

→ see lectures Stahlbeton I and Advanced Structural Concrete for principles (figures for illustration)

Stress field
(plan, half
flange)

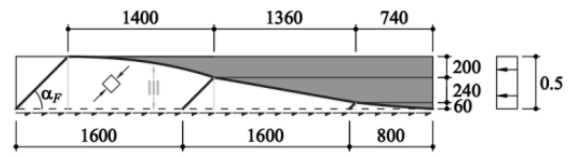

Shear flow (per
side assumed)

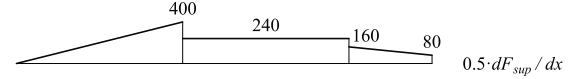

Membrane shear
forces in deck

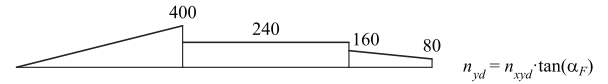

Transverse
reinforcement
demand

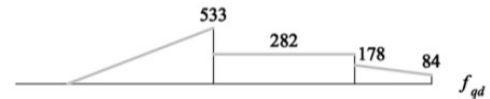

Strut-and-tie
model (plan,
full flange)

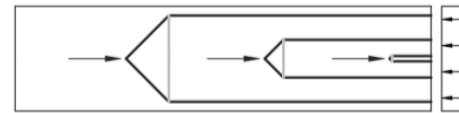

Structural analysis and design – Shear Connection

Failure of shear connection (experimental investigation by Dr. A. Giraldo, UP Madrid)

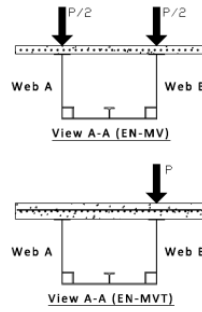
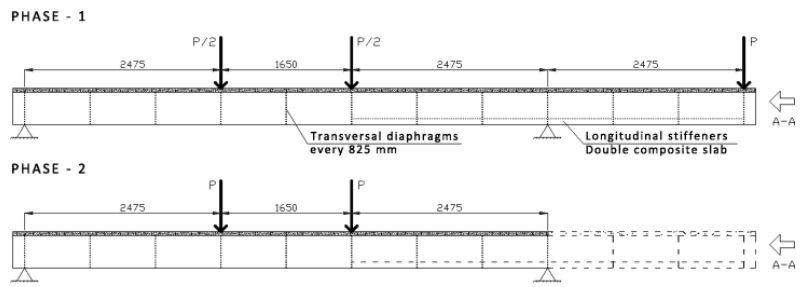
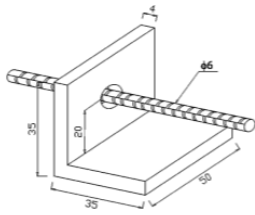

Structural analysis and design – Shear Connection

Failure of shear connection (experimental investigation by Dr. A. Giraldo, UP Madrid)



Superstructure / Girder bridges

Design and erection

Steel and steel-concrete composite girders

Structural analysis and design – Further aspects

Structural analysis and design – Shear capacity of composite girders

Shear Capacity of composite girders

- In the design of steel-concrete composite girders, the shear capacity is determined for the steel girder alone (neglecting any contribution of the concrete deck)
- Webs are often slender to save weight → post-critical shear strength, see lectures Stahlbau (illustrated schematically in figure)
- While neglecting the concrete deck is conservative, it may make sense to activate the considerable reserve capacity provided by the concrete deck in composite (box girder) bridges with slender webs
 - the figure shows the extended Cardiff model (see notes), considering the flange moments of the composite flange instead of just those of the steel flange, thereby enhancing the post-critical tension field in the web

Shear strength of slender web (post-critical behaviour)

$$V_{Rd} = V_{\sigma,d} + V_{\tau,d} \quad (\text{interior panel})$$

$$V_{Rd} \geq \frac{0.9 \cdot \sqrt{\tau_{cr} \cdot \tau_y} \cdot b \cdot t_w}{\gamma_{M1}} \quad (\text{end panel})$$

$$V_{\sigma,d} = (h - t_f) \cdot t_w \cdot \frac{\sqrt{\tau_y \cdot \tau_{cr}(a,b)}}{\gamma_{M1}} \cdot \left(1 - \frac{\tau_{cr}(a,b)}{\tau_y}\right)$$

$$V_{\tau,d} = (h - t_f) \cdot t_w \cdot \frac{\tau_{cr,\min}(a',b')}{\gamma_{M1}}$$

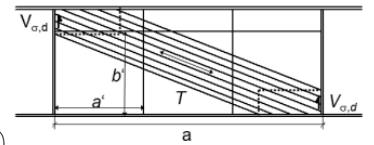

Posts

$$s_{,erf} = \left(\frac{h - t_f}{50}\right)^4$$

$$A_{s,erf} = (V_s / f_y - 25 \cdot t_w^2) \cdot 2.1$$

$$l_{cr} = 0.75 \cdot (h - t_f)$$

$b_{eff} = 25 t_w$

Extended Cardiff model (see notes and references)

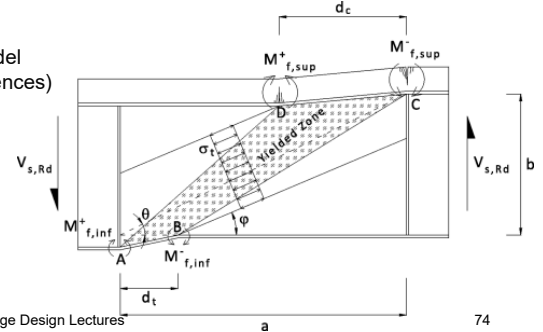

In composite girders only the steel beam is considered in the calculation of the shear capacity. However, recent studies have confirmed a significant contribution of the concrete slab [3,4] and composite action (in case of slender webs) [1,2] to the shear resistance.

The direct contribution of the concrete deck (i.e., the shear strength of slab) is of brittle nature, and neglecting its contribution is similar to concrete bridge design; superposition with the shear strength of the webs is basically possible, but requires in-depth analyses that are not suitable for design.

The effect of composite action is more interesting in this respect. Here, a higher post-critical shear resistance can be achieved due to the increase of the tension field produced by composite action. The bottom figure in the slide shows an extension of the Cardiff model capable of accounting for this effect. The model is generalized to consider the flange moments of the composite flange instead of just that of the steel flange.

[1] A. Giraldo Soto, A. Pérez Caldentey, H. Corres Peiretti, J.C. Benítez, “Experimental behaviour of steel-concrete composite box girders subject bending, shear and torsion”, *Engineering Structures*, 206, 2020.

[2] S. Darehshouri, N. Shanmugam and S. Osman, “Collapse behavior of composite plate girders loaded in shear,” *Journal of Structural Engineering*, vol. 138, pp. 318-326, 2012.

[3] Marí, A. Cladera, J. Bairán, E. Oller and C. Ribas, “Un modelo unificado de resistencia a flexión y cortante de vigas esbeltas de hormigón armado bajo cargas, puntuales y repartidas,” *Hormigón y Acero*, pp. 247-265, 2014.

[4] C. Ribas González and M. Fernandez Ruiz, “Influence of flanges on the shear-carrying capacity of reinforced concrete beams without web reinforcement,” *Structural Concrete*, vol. 18, no. 5, pp. 720-732, 2017.

Upper figure adapted from Vogel, *Brückenbau*, Lower figure from [1]

Structural analysis and design – Specific aspects

Cracking

- Unless longitudinally prestressed (which is very uncommon), the deck of composite girders is subjected to tension in the support regions and will crack in many cases
- Tensile stresses in the deck can be reduced by staged casting of the deck (cast support regions last → see erection)
- The reduced stiffness caused by cracking in the support regions should be considered in the global analysis, by using the cracked elastic stiffness EI' :
 - determine cracked regions based on linear elastic, uncracked analysis
 - re-analyse global system with cracked stiffness (based on results of uncracked analysis, see notes)
 - iterate if required
 - tension stiffening of the deck reinforcement is often neglected (consider bare reinforcing bars)
- For similar adjacent spans ($l_{min} / l_{max} < 0.6$), assuming a cracked stiffness over 15% of the span on either side of the supports is usually sufficient, see figure

Simplified method to consider cracking of deck

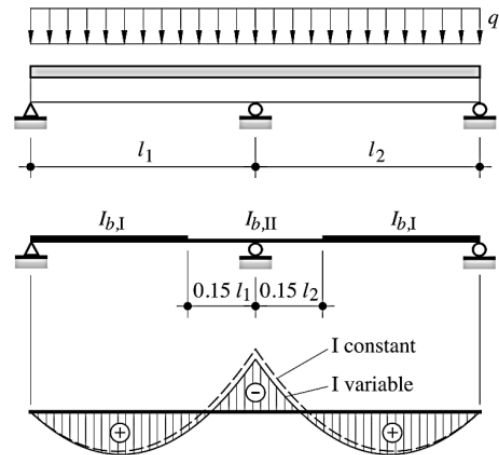

[Lebet and Hirt (2013)]

EN1994-2 recommends to use the characteristic loads in SLS in the initial, uncracked analysis, including long term effects. Based on the obtained bending moment diagram, the zones where the stresses in the extreme concrete fibres exceed twice the average tensile concrete strength f_{ctm} should be assumed to be cracked in the next iteration.

Structural analysis and design – Specific aspects

Long-term effects – Shrinkage

- Shrinkage of the deck concrete is restrained by the steel girders → self-equilibrated stress state
- For practical purposes, only the final value of the restraint stresses and strains is of interest, which can be determined using $E_{c,eff} \approx E_c/2$ to account for concrete relaxation:

1. Consider section as fully restrained ($\varepsilon = 0$) → shrinkage of the concrete fully restrained, tensile force in deck:

$$N_{cs} = E_{c,eff} A_c \varepsilon_{cs} \quad (\varepsilon_{cs} < 0)$$

2. Release restraint of section → by equilibrium, a compressive force N_{cs} and a positive bending moment $a_c \cdot N_{cs}$ must be applied to the composite section ($M=N=0!$)
3. Determine stresses in steel girder (due to step 2 only) and concrete deck (superposition of step 1 and 2)
4. Apply resulting curvature and strain as imposed deformation in global analysis

Strains and stresses due to shrinkage of the deck

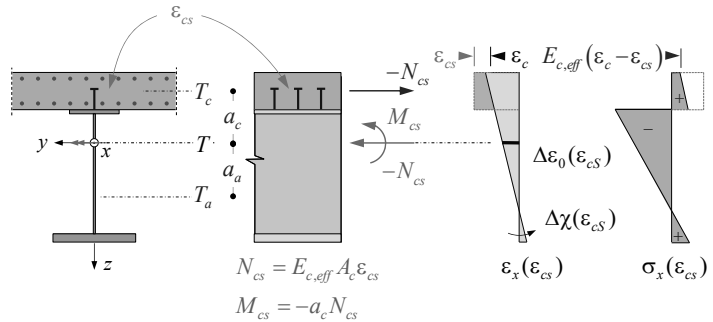

Imposed deformation on girder in global analysis
(→ restraint forces in statically indeterminate structures, causing additional longitudinal shear)

$$\Delta\varepsilon_0(\varepsilon_{cs}) = \frac{N_{cs}}{E_a A_b}, \quad \Delta\chi(\varepsilon_{cs}) = -\frac{N_{cs} \cdot a_c}{E_a I_{yb}}$$

(compressive strain, positive curvature)

The development of shrinkage stresses over time can be determined using the Method of Trost (Advanced Structural Concrete)

The positive bending moment M_{cs} is referred to as *primary moment* on the following slides.

Structural analysis and design – Specific aspects

Long-term effects – Shrinkage

- Restrained shrinkage causes tension in the deck and compression in the steel girders
- Typically, tensile stresses of about 1 MPa result in the deck → uncracked unless additional tension is caused by load
- The corresponding deformations of the composite section (compressive strain, positive curvature) are imposed to the girder for global analysis → deformations (sagging) of the girder → restraint in statically indeterminate structures
- At the girder ends, the deck is stress-free → normal force in deck (= normal force in steel must be introduced → shear connection must resist horizontal force H_{vs} at girder ends → usually distributed over a length corresponding to the effective width of the deck (still requires dense connector layout at girder ends)
- Differential temperature is treated accordingly (also requires load introduction at girder ends)

Strains and stresses due to shrinkage of the deck

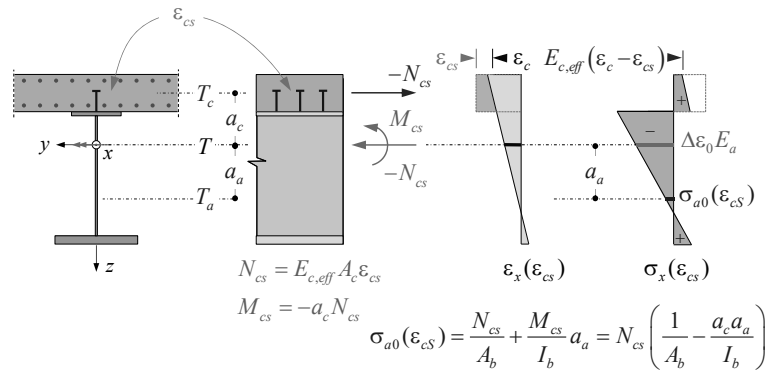

Horizontal force to be transferred at girder ends by shear connection due to shrinkage

$$H_{vs} = \sigma_{a0}(\varepsilon_{cs}) \cdot A_a = \left(\frac{N_{cs}}{A_b} + \frac{M_{cs}}{I_b} a_a \right) \cdot A_a$$

For an isostatic girder, the normal stresses due to shrinkage are constant along the length of the beam, in equilibrium within a given cross section, and result in no additional shear force in the steel-concrete connection. At the girder ends the normal stresses are zero. This means that the normal force H_{vs} , which results from the stresses acting in the slab, must be introduced at the beam ends. This force acts locally on the steel-concrete connection in these regions (see *steel-concrete shear connection* section).

The normal force in the slab F_{vs} , which must be anchored by the shear connectors at the beam ends, is equal to the resultant of the normal force acting in the steel section, namely the stress σ_{a0} due to shrinkage, acting at the centre of gravity z_a of the steel section, multiplied by the steel area A_a .

Illustrations adapted from J.P. Lebet and M.A. Hirt, Steel bridges

Structural analysis and design – Specific aspects

Long-term effects – Shrinkage

- The redundant forces (bending moments and shear forces) can be obtained by applying the primary moment M_{cs} and the normal force $-N_{cs}$ to the girder (see e.g. Lebet and Hirt, Steel bridges)
- This may however be misleading in case of a plastic design (M_{cs} and N_{cs} are no action effects when considering the entire girder)
- Alternatively, one may simply impose the compressive strain and positive curvature caused by shrinkage to the girder:

$$\Delta\varepsilon_0(\varepsilon_{cs}) = \frac{N_{cs}}{E_a A_b}, \quad \Delta\chi(\varepsilon_{cs}) = -\frac{N_{cs} \cdot a_c}{E_a I_{yb}}$$

- The resulting redundant moments – to be superimposed with the primary moment to obtain stresses in the steel girder – are schematically shown in the figure (smaller in case of cracked deck)
- The corresponding shear forces need to be considered when designing the shear connection

Redundant moments due to shrinkage, deck uncracked over supports

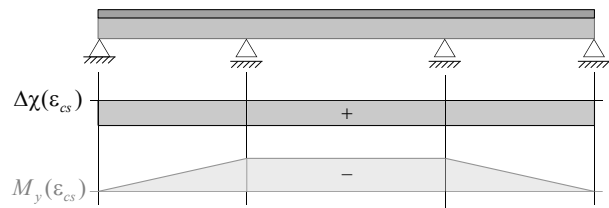

Redundant moments due to shrinkage, deck cracked over supports

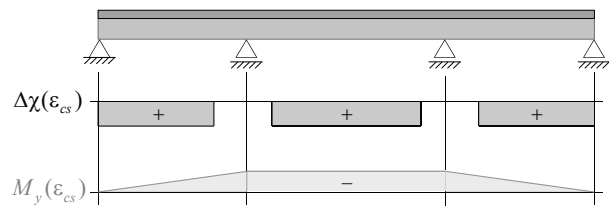

For a continuous beam, to ensure continuity of curvature over the intermediate supports, shrinkage results in redundant negative bending moments. The vertical and longitudinal shear forces corresponding to these moments act on the steel-concrete connection.

In the figure, it has been neglected that the imposed curvature should build up over a certain distance at girder ends and uncracked region borders.

Structural analysis and design – Specific aspects

Long-term effects – Creep

- Creep of the deck causes a stiffness reduction from $E_a \cdot I_{b,0}$ to $E_a \cdot I_b(t)$ due to creep in the time interval t_0 to t , which is accounted for by adjusting the modular ratio n_{el} , see formulas
- Note that all transformed section properties depend on the effective modulus of the concrete via n_{el} and hence, change due to creep
- Creep is relevant only for permanent loads applied to the composite girder
 - little effect if deck is cast on unpropped steel girders
- In statically determined structures (simply supported girders), creep of the deck causes
 - increased deflections
 - stress redistribution in the cross-section since concrete creeps, but steel does not
 - no changes in the action effects (bending moments and shear forces)

Changes in stresses due to creep (exaggerated)

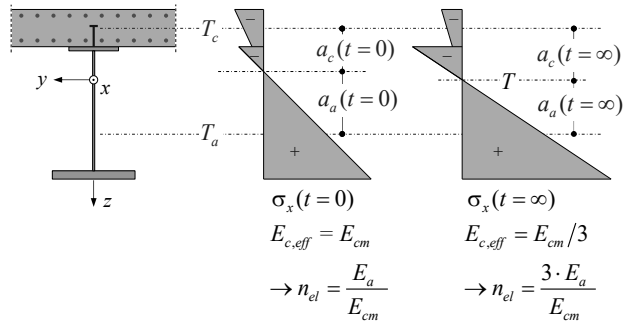

$$A_b = A_a + \frac{A_c}{n}, \quad a_a = a \frac{A_c/n}{A_b}, \quad a_c = a \frac{A_a}{A_b}$$

$$I_{yb} = I_{ya} + a_a^2 A_a + \frac{I_{yc}}{n} + a_c^2 \frac{A_c}{n} = I_{ya} + \frac{I_{yc}}{n} + a_a a_c A_b$$

Structural analysis and design – Specific aspects

Long-term effects – Creep

- In statically indeterminate structures (continuous girders), creep of the deck causes
 - increased deflections (as in simply supported girders)
 - stress redistribution in the cross-section (as in simply supported girders)
 - changes in the action effects (bending moments and shear forces), that can be determined e.g. using the time-dependent force method (or simply by using section properties based on the appropriate effective modulus of the concrete)
- The cracked regions above supports are not affected by creep
 - moment redistribution due to creep causes higher support moments and reduced bending moments in the span (“counteracts” cracking)
 - higher shear forces near supports and correspondingly, higher longitudinal shear (shear connection!)

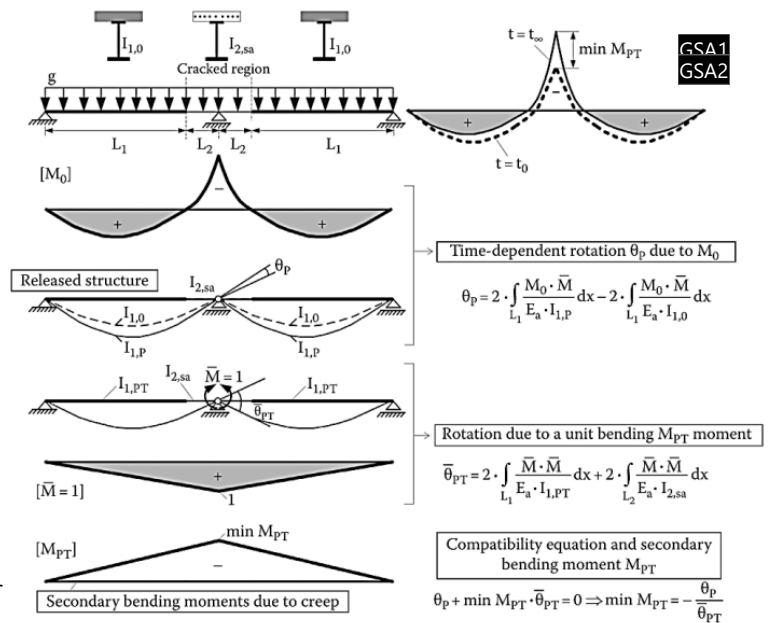

03.03.2025

ETH Zürich | Chair of Concrete Structures and Bridge Design | Bridge Design Lectures

80

Secondary bending moments due to creep in continuous beams have the followings effects:

- Increased deflections
- Changes in the internal action effects (bending moments, shear forces) with an increase of moments at the supports and moment reduction in the spans (if cracking is accounted for, creep does not affect negative moment regions)
- Corresponding shear forces that induce longitudinal shear forces at the interface between the concrete slab and the steel beam
- Stress redistribution in the cross sections at sagging moment areas, where the stresses in the steel girders are increased, while the stresses in the concrete slab are decreased

Illustration adapted from I. Vayas and A. Iliopoulos, Design of steel-concrete composite bridges to Eurocode

Superstructure / Girder bridges

Design and erection

Steel and steel-concrete composite girders

Construction and erection

Steel and composite girders – Construction and erection

Construction of the concrete slab

- Slab cast in-place ← most common
- Slab composed of precast elements
- Slab launched in stages

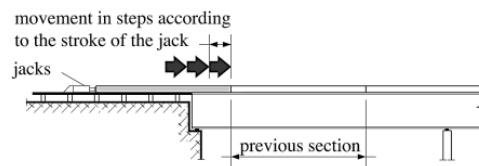
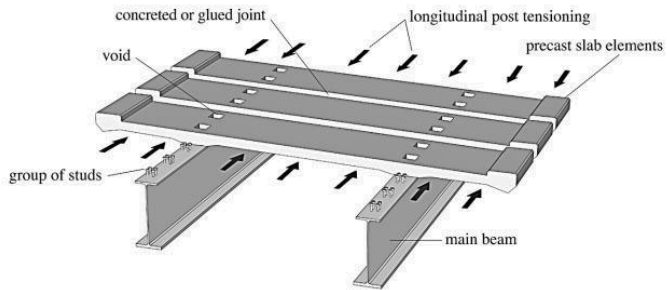

Photo: Viaduct over the Mularroya Dam, Spain © IDEAM; Illustration adapted from J.P. Lebet and M.A. Hirt, Steel bridges

Steel and composite girders – Construction and erection

Construction of the concrete slab

- Cast-in-place decks can be built using
 - conventional formwork supported independently (shoring) → propped construction (often inefficient)
 - conventional formwork supported by the steel girders (limited efficiency)
 - lightweight precast concrete elements (“concrete planks”), usually stiffened by reinforcing bar trusses serving as
 - ... lost formwork (not activated in final deck)
 - ... elements fully integrated in the final deck (reinforcement activated, requires elaborate detailing)
 - mobile formwork (deck traveller)
 - ... geometry and cross-section \approx cte.
 - ... usual length per casting segment ca. 15...25 m
- Wide cantilevers are often challenging for the formwork layout

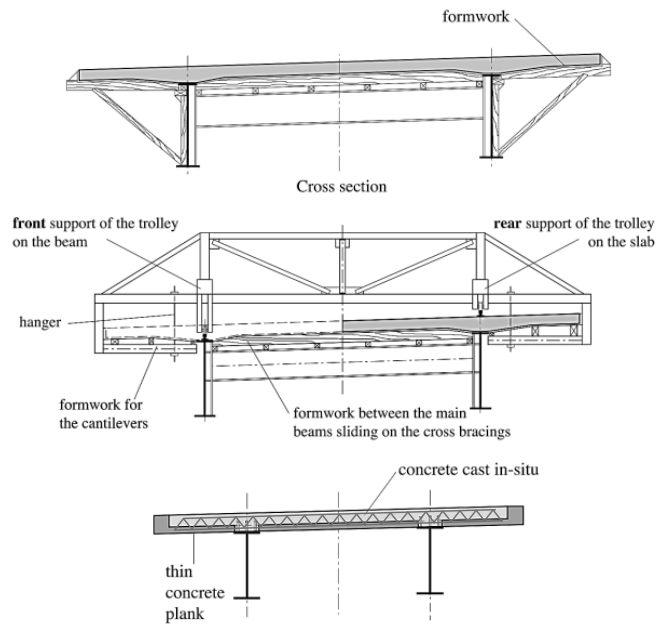

Illustration adapted from J.P. Lebet and M.A. Hirt, Steel bridges

Steel and composite girders – Construction and erection

Construction of the concrete slab

- Cast-in-place deck built using precast concrete elements



03.03.2025



ETH Zürich | Chair of Concrete Structures and Bridge Design | Bridge Design Lectures

84

Photo: Sigüés viaduct, Spain © IDEAM

Steel and composite girders – Construction and erection

Construction of the concrete slab

Concreting sequence (slab cast in-place)

- The construction sequence of the deck is highly relevant for
 - the efficiency of construction
 - the durability of the deck (cracking)
- Simply supported bridges (single span) up to ca. 25 m long are usually cast in one stage.
- For longer spans, the weight of the wet concrete causes high stresses in the steel girders, which might be critical in SLS and in an elastic design; furthermore, large deformations must be compensated by camber (higher risk of deviations in geometry).
- Alternatively, the slab may be cast in stages, first in the span region and then near the ends.



Steel and composite girders – Construction and erection

Construction of the concrete slab

Concreting sequence (slab cast in-place)

- The slab in continuous bridges is usually cast in stages in order to limit the tension stresses of concrete above intermediate supports.

→ Sequential casting, from one end to the other

→ Sequential casting, span before pier
(preferred for structural behaviour, but less efficient in construction)

→ Sequential casting, span by span
concreting

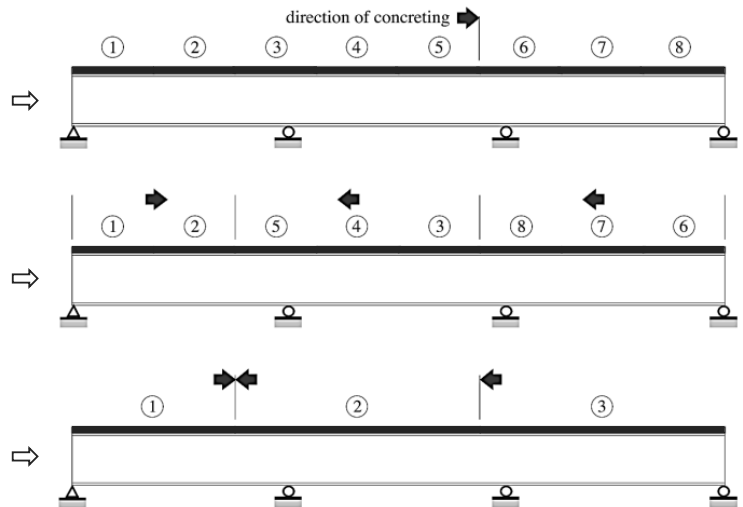

- Sequential concreting, from one end to the other: for small-span bridges / hogging moments is not an issue / continuous concreting may be followed / the simplest method that contractors prefer
- Sequential concreting, span before pier concreting: the bending moments at intermediate supports are reduced / the length of the cast parts varies between 15 and 25 m / movements of the formworks elements over cast deck regions are required
- Sequential concreting, span by span concreting: increasing the length of the concreting stages limits the number of formwork displacements and avoids movements of the trolley over cast deck regions

Illustration adapted from J.P. Lebet and M.A. Hirt, Steel bridges

Steel and composite girders – Construction and erection

Construction of the concrete slab

Concreting sequence (slab cast in-place)

- The slab in continuous bridges is usually cast in stages in order to limit the tension stresses of concrete above intermediate supports.
 - Sequential casting, from one end to the other
 - Sequential casting, span before pier (preferred for structural behaviour, but less efficient in construction)
 - Sequential casting, span by span concreting



Erection of the steel member with temporary supports

Erection of the steel girders with temporary supports in order to limit stresses in the steel girders.

Photo: Highway A-357, Guadalhorce-Connection, Spain © IDEAM

Steel and composite girders – Construction and erection

Steel girder erection
Lifting with cranes



03.03.2025

ETH Zürich | Chair of Concrete Structures and Bridge Design | Bridge Design Lectures

88

Lifting steel members with cranes is often the most economical method for the erection of small and medium-span bridges.

The limitations are the same as for precast concrete girders:

- weight (crane capacity)
- sites with easy access for trucks and cranes (girder delivery and lifting)

Photos: left: Viaduct over the River Tagus in Talavera de la Reina, Spain © IDEAM; right: Viaduct over the Mularroya Dam, Spain © IDEAM

Steel and composite girders – Construction and erection

Steel girder erection
Lifting with cranes (floating)



03.03.2025

ETH Zürich | Chair of Concrete Structures and Bridge Design | Bridge Design Lectures

89

Photos: Puente Porta d'Europa, Barcelona, 2000. Arenas&Asociados. World's second largest floating crane at the time lifting the entire leaf (1100 t) of the bascule bridge.



Kanton Zürich
Baudirektion
Tiefbauamt

dsp | INGENIEURE & PLANER AG



Steel and composite girders – Construction and erection

Steel girder erection

Free / balanced cantilevering (lifting frames)



03.03.2025

ETH Zürich | Chair of Concrete Structures and Bridge Design | Bridge Design Lectures

91

Photos: Ulla viaduct, Spain © IDEAM

Steel and composite girders – Construction and erection

Steel girder erection
Launching



03.03.2025

ETH Zürich | Chair of Concrete Structures and Bridge Design | Bridge Design Lectures

92

Photo: <https://www.financialexpress.com/>

Video adapted from https://www.youtube.com/watch?v=MbpeJ_3XH9c

Steel and composite girders – Construction and erection

Steel / composite girder erection

Transverse launching (shifting)

- Example: Replacement of Quaibrücke Zürich, 1984
- New bridge: Steel-concrete composite, $l=121$ m, spans $22.6+24.8+26.5+24.8+22.6$ m, width 30.5 m
- Appearance had to mimic old bridge (Volksinitiative), but only 4 instead of 8 girders, ca. 50% steel weight)

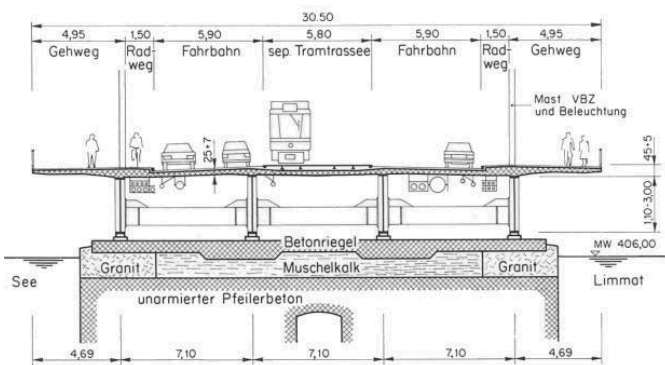

03.03.2025

ETH Zürich | Chair of Concrete Structures and Bridge Design | Bridge Design Lectures

New bridge under construction (downstream of old bridge)



93

New Quaibrücke Zürich, Fietz+Leuthold AG (1984). Replacement of existing bridge by transverse launching.

Figures: R. Heierli et al., Quaibrücke Zürich, Schweizer Ingenieur und Architekt, Vol. 103 (1985), No. 10, pp. 183-195

Photos: e-pics.ethz.ch

Steel and composite girders – Construction and erection

Steel / composite girder erection

Transverse launching (shifting)

- Old and new bridges connected for launching, total weight launched 7'800 t
- Bridge closed to traffic:
Fri 16.3.1984, 21:00 to Mon 19.3.1984, 06:00
- Launching: Sat 17.3.1984, 00:00-15:15 h
(net 14 h launching time)

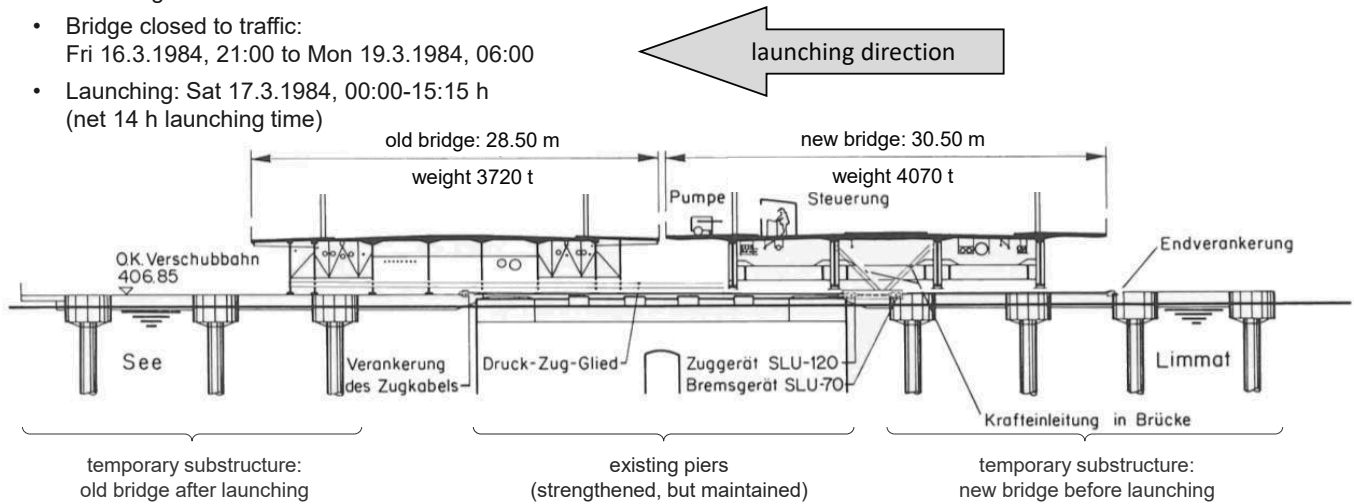

03.03.2025

ETH Zürich | Chair of Concrete Structures and Bridge Design | Bridge Design Lectures

94

Figures: R. Heierli et al., Quaibrücke Zürich, Schweizer Ingenieur und Architekt, Vol. 103 (1985), No. 10, pp. 183-195

Photos: e-pics.ethz.ch

Steel and composite girders – Construction and erection

Steel / composite girder erection
Transverse launching (shifting)

New bridge and temporary substructure in lake under construction



03.03.2025

New bridge and launching tracks (almost) ready for launching



ETH Zürich | Chair of Concrete Structures and Bridge Design | Bridge Design Lectures

95

Photos: e-pics.ethz.ch

Steel and composite girders – Construction and erection

Steel / composite girder erection
Transverse launching (shifting)

Two bridges travelling towards the lake



03.03.2025

Demolishment of old bridge



ETH Zürich | Chair of Concrete Structures and Bridge Design | Bridge Design Lectures

96

Photos: e-pics.ethz.ch