

Advanced Structural Concrete - Colloquium 4

(101-0127-00L)

Topic: Slabs

Skew-supported slab

Hand out: 14. December 2023, HIL E 7

1 Dimensioning bases of the exercise

1.1 Introduction

In this exercise, a slab will be dimensioned and discussed at the ultimate limit state type 2 according to the structural design standards SIA 260 to 262 [1 – 3]. This exercise examines a skew-supported bridge slab.

1.2 Geometry

The dimensions can be taken from Figure A1. The bridge slab has a thickness of $h = 0.45$ m.

1.3 Material

For the construction of the bridge, a concrete C30/37 and construction steel B500B are used.

1.4 Exposure classes

The skew plate is exposed to weather conditions as well as de-icing salts and is situated in an environment with changing humidity. The concrete cover is $c_{nom} = 55$ mm.

1.5 Loads

The slab is subjected to its dead weight, the self-weight of non-structural elements of $g_{1k} = 3$ kN/m², and a live load of $q_k = 15$ kN/m² (characteristic values, acting on the entire surface of the slab). The loads are to be combined according to SIA 261 [2].

2 Task

Dimension the slab based on the results of an elastic FEM-calculation (Figures A2.1 to A2.7).

3 Literature

- [1] Swiss society of engineers and architects (SIA), standards: SIA 260 Basis of Structural Design, 2003
- [2] Swiss society of engineers and architects (SIA), standards: SIA 261 Actions on Structures, 2003
- [3] Swiss society of engineers and architects (SIA), standards: SIA 262 Concrete Structures, 2003
- [4] FEM Software, CEDRUS-7, Cubus AG, Zürich

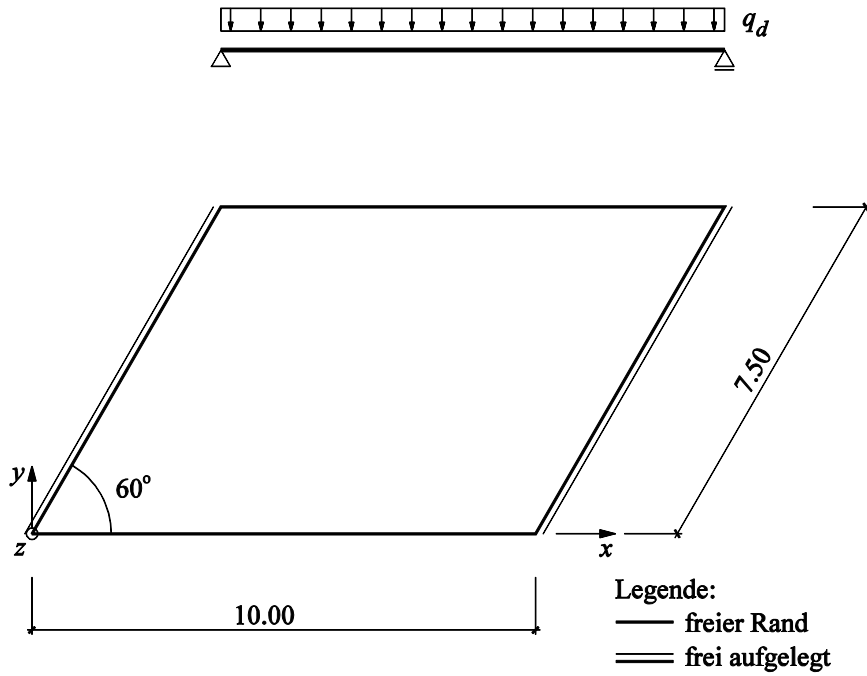
Appendix A - Figures**A1 Floor plan and side view of the skew-supported slab, dimensions in [m].**

A2 Results of a FEM-Calculation for a skew-supported slab

A2.1 Structure and support of the slab. Reference load $p = -100 \text{ kN/m}^2$ (acting on the entire surface, z -direction out of plane), dimensions in [m]



A2.2 Internal force m_x in [kNm/m] resulting from reference load $p = -100 \text{ kN/m}^2$, contour lines at 50 kNm/m, dimensions in [m]

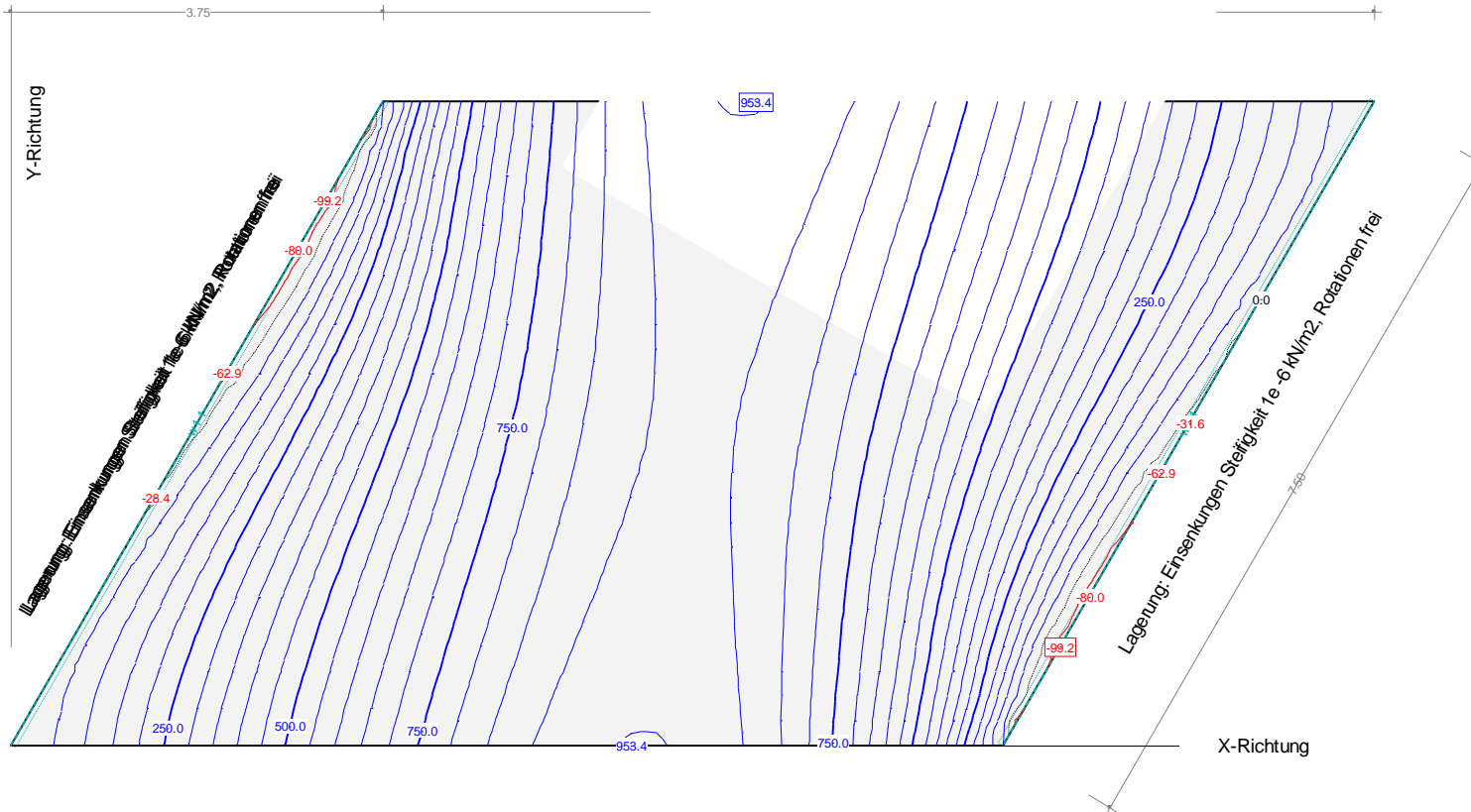

A2.3 Internal force m_y in [kNm/m] resulting from reference load $p = -100 \text{ kN/m}^2$, contour lines at 20 kNm/m, dimensions in [m]

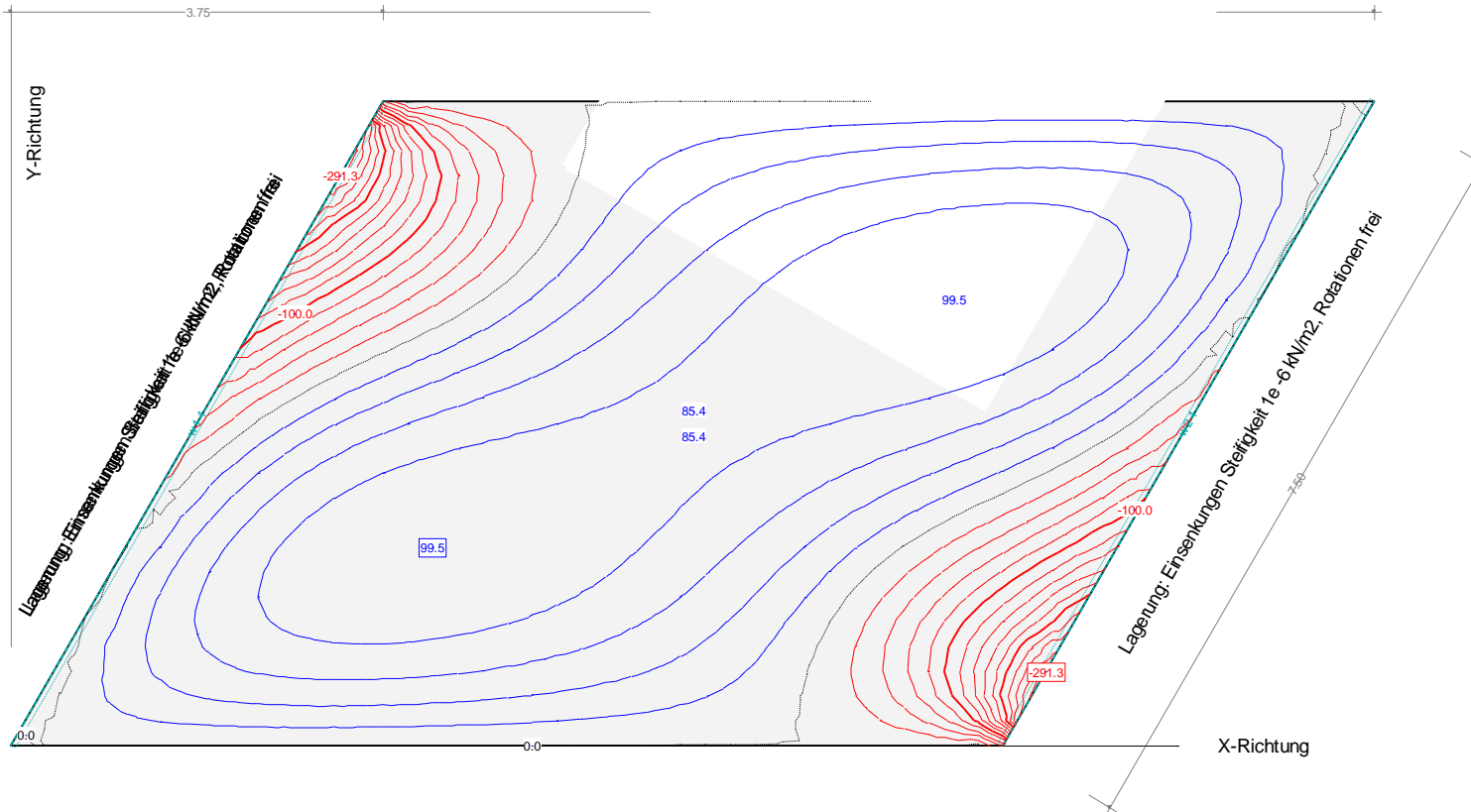

A2.4 Internal force m_{xy} in [kNm/m] resulting from reference load $p = -100 \text{ kN/m}^2$, contour lines at 10 kNm/m, dimensions in [m]

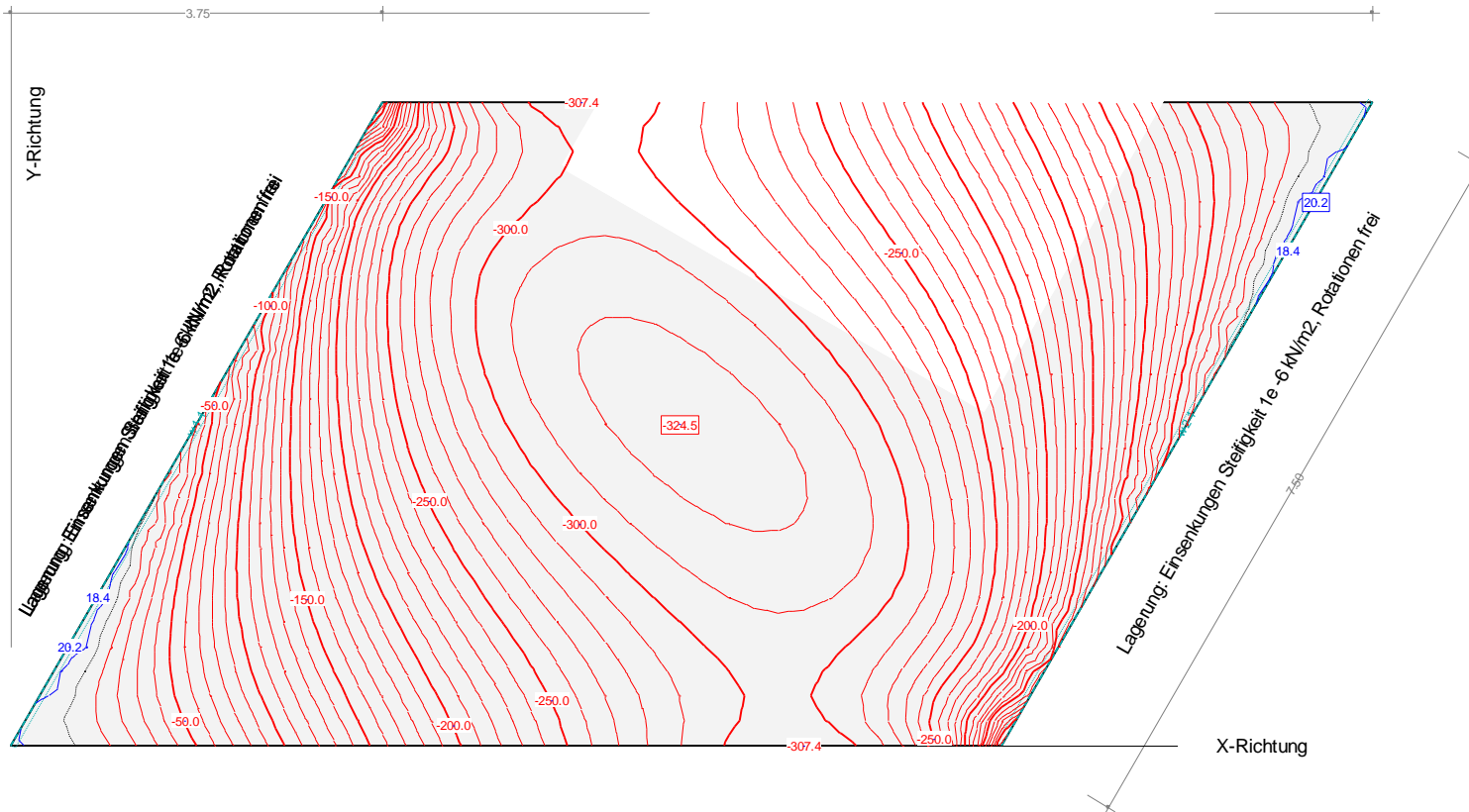

A2.5 Internal force v_x in [kN/m] resulting from reference load $p = -100 \text{ kN/m}^2$, contour lines at 25 kNm/m, dimensions in [m]

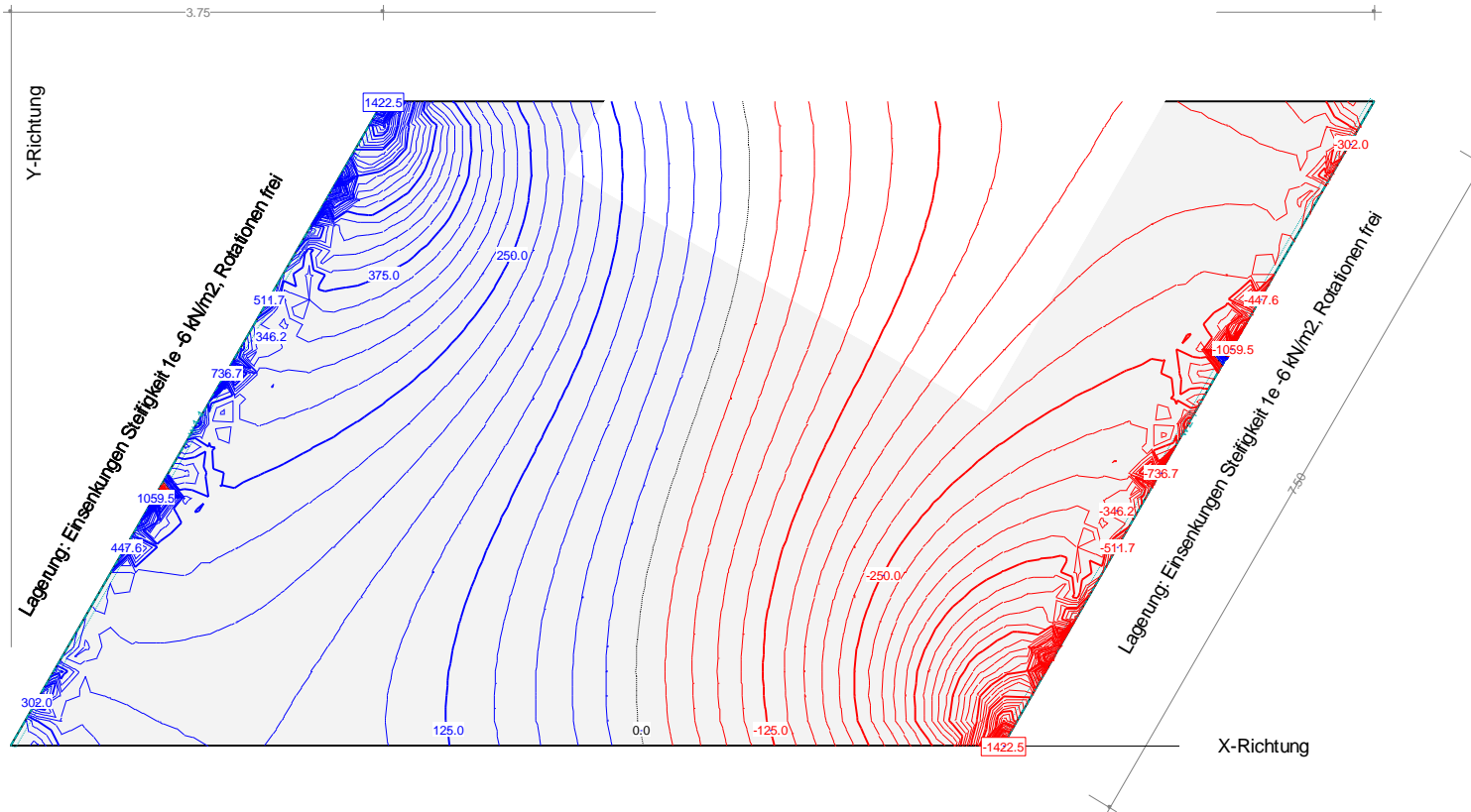

A2.6 Internal force v_y in [kN/m] resulting from reference load $p = -100 \text{ kN/m}^2$, contour lines at 25 kNm/m, dimensions in [m]

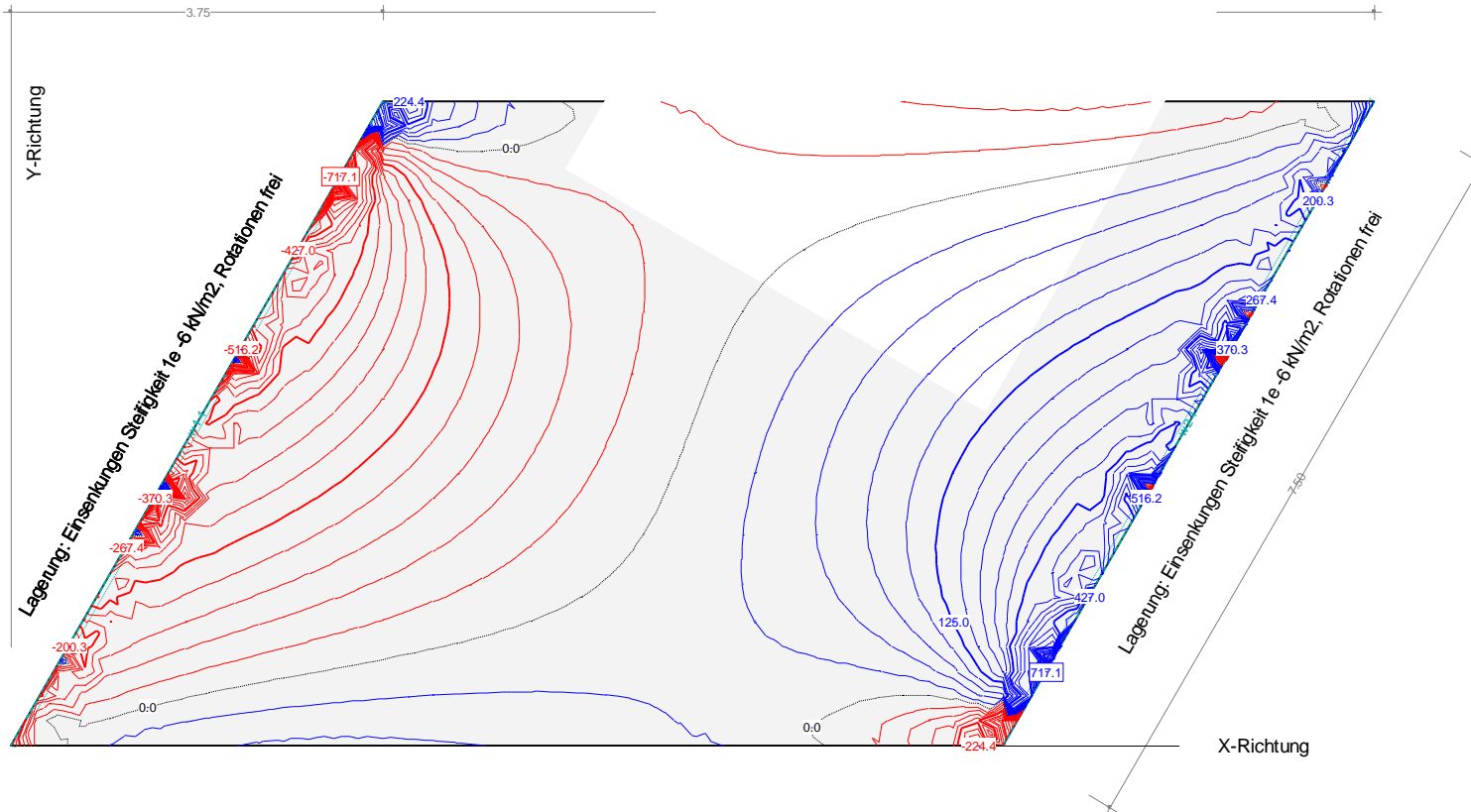

A2.7 Support reaction in [kN/m] resulting from reference load $p = -100 \text{ kN/m}^2$, averaged in parts, dimensions in [m]

