

6 Fire behaviour of concrete structures

This chapter:

- introduces the thermal and mechanical behaviour of concrete and reinforcement exposed to fire,
- shows structural actions and deformations specifically occurring in the case of fire
- introduces and evaluates design methods provided in SIA 262/ SN EN 1992-1-2, as well as
- discusses the issue of explosive fire spalling of concrete.

Fire behaviour of concrete structures

What members require closer fire engineering consideration when designing concrete structures?

Fire behaviour of concrete structures

SIA 262: Table 16

Fire resistance class	Minimum cover of reinforcement [mm]	Minimum member dimensions [mm]					
		Columns	Walls	Slabs	Mushroom slabs	Flat slabs	T-beam web width
R 30	20	150	120	60	150	150	100
R 60	20	200	140	80	150	200	150
R 90	30	240	170	100	150	200	200
R 120	30	280	220	120	150	200	300
R 180	40	360	300	150	200	200	400

Fire behaviour of concrete structures

Summary ▶

What members require closer fire engineering consideration when designing concrete structures?

Introduction

Fire in warehouse, Gent (1974)



- Dimensions of warehouse 50 m x 50 m in plan
- Shear failure of the façade mullions after 120 min due to thermal expansion of the beams.

Fire in underground car parking, Gretzenbach (2004)



- Burning car as trigger to collapse
- Collapse due to various drivers

- Gent:
 - The warehouse was half filled with cotton bales (one part of the warehouse was exposed to fire, the other not).
 - The part of the warehouse not exposed to fire braced the overall building during fire.

Introduction

Explosive spalling ▶

Fire in underground car parking, Rotterdam (2007)



- Five cars burned out completely.
- Parts of the slab collapsed during and after the fire

Fire in warehouse, near Milano (2018)



- Premature failure of a beam's web due to extensive spalling

Introduction

Fire in St. Gotthard tunnel (2001)



- Opened 1980
- Length = 16.9 km
- Damages repaired after fire (tunnel in operation today)

- Suspended ceiling with severe damages over a length of around 230 m

- 11 fatalities
- Outdated ventilation

Introduction

Fire in Eurotunnel (Ärmelkanal) (1996)



- Opened 1994
- Length = 50.45 km
- Damages repaired after fire (tunnel in operation today)

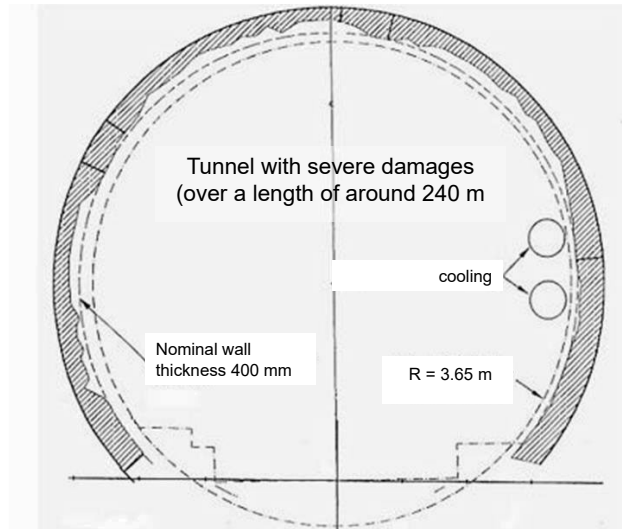

- No fatalities

Introduction

Fire in seven-storey car park (Liverpool Echo Arena, 31.12.2017)



Concrete structures generally exhibit an advantageous behaviour in fire conditions because:

- Concrete is heated comparably slowly (low thermal conductivity, high specific heat) and, therefore, protects the reinforcement from heating
- Concrete cross-sections are comparably massive
- Concrete is non-combustible

- Dimensions: 70 m x 60 m
- Precast beams and ribbed slabs
- Approx. 1400 cars destroyed

The car park was built in 2006 as part of the Liverpool Echo Arena development on land adjacent to the River Mersey. The overall size is approximately 70 m x 60 m with columns spaced approximately 7 m apart in the shorter direction. Beams are supported by the columns to allow for a large span in the longer direction. The columns and beams are comparably massive. Between the beams, prefabricated ribbed ceilings with a span of approx. 7 m were provided.

Fires in multi-storey car parks are not uncommon. However, the Liverpool fire was unprecedented in its scale because the initial fire in one car quickly spread to other vehicles. The building had a solid reinforced concrete frame that withstood the fire on a global scale. Some of the prefabricated ribbed ceilings were severely damaged or collapsed completely. Otherwise, the staircase cores remained practically undamaged, apart from some cracks, which were probably due to different thermal movements during and after the fire. Likewise, the fire doors were functioning after the fire.

As an open car park, only a 15 minute fire rating would have been required under Approved Document (AD) Part B [1]. The fact that the building withstood a hydrocarbon curve type fire for several hours with limited damage showcases the inherent robustness and fire resistance of reinforced concrete structures under fire conditions.

Reference: www.structural-safety.org

Learning objectives

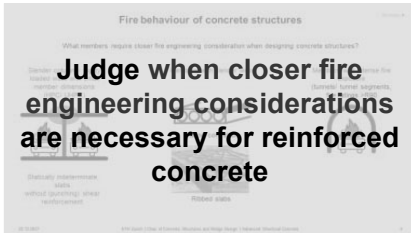

Describe the material behaviour under fire conditions

Describe the structural behaviour under fire conditions

Identify the most suitable verification method(s) for the fire design

Apply simplified design methods and understand their relation to design methods at ambient temperature

Understand the need for design verifications related to explosive spalling and use the appropriate measure to deal with it

Standardisation - Overview

- The design provisions given in SIA 260-262 on the fire behaviour of concrete structures are limited to basic information.
 - SIA 261:2014 defines basic principles of thermal and mechanical actions and the fire protection concept.
 - SIA 262:2013 (Corrigenda 2017) mainly provides basic rules for structural analysis. Table 16 may be used for very simple member verification.
- For further information and calculation principles, reference is made to the European standards SN EN 1991-1-2 and SN EN 1992-1-2.
- SN EN 1992-1-2 allows two different approaches for design:
 - Design based on prescriptive rules (thermal actions given by nominal fire curves)
 - Design based on performance-based specifications (physically based thermal actions)
- The European structural standards are currently under revision. It is planned to establish the revised EN 1992-1-2 in approx. 2024.



Actions under fire conditions

Fire = accidental design situation (SIA 260/261):

$$\rightarrow E_{d,fi} = E\{G_k, P_k, A_d, \Psi_{2i}, Q_{ki}, X_d, a_d\} = E\left\{ \underbrace{G_k, P_k}_{\text{Permanent action incl. P}}, \underbrace{A_d}_{\text{Design value of accidental action}}, \underbrace{\Psi_{2i}, Q_{ki}}_{\text{Variable action: quasi-permanent value}}, \underbrace{X_d, a_d}_{\text{Design value of construction material or ground property and geometrical properties}} \right\}$$

- bridges: no variable actions to be considered
- reinforced concrete buildings: variable actions of $\approx 70\%$ of characteristic action to be considered ($\eta_{fi} = E_{d,fi}/E_d \approx 0.7$)

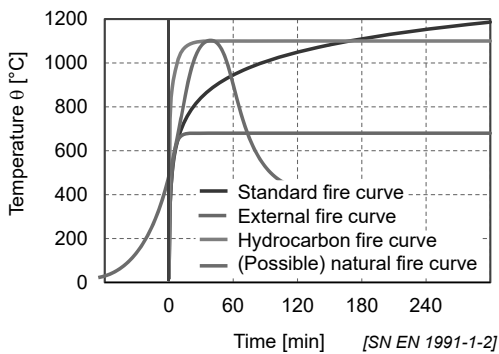

The effects of a fire event are usually taken into account with nominal temperature-time curves:

- Buildings: Fire resistance classification according to the standard temperature-time curve (ETK = Einheitstemperaturzeitkurve, typical designations: "Standard fire curve", "ISO 834").
- Fire load in reinforced concrete buildings only depends on the amount of available combustible material within fire compartments of concern (\rightarrow uncertainty)
- Tabulated design data, simplified design methods and design provisions for explosive spalling: only valid for the Standard fire curve
- Tunnels: Hydrocarbon curve / project-specific curves

- The quotient of $E_{d,fi}$ and E_d results in η_{fi} according to SN EN 1992-1-2. SN EN 1992-1-2 recommends a conservative value of $\eta_{fi} = 0.7$ as a simplification for reinforced concrete structures.
- The heating rate influences the transient heat flow through the member as well as the probability of explosive spalling. With other temperature-time curves, it must be ensured that the material models presented below are valid, especially if a cooling phase needs to be considered. Further, rapid heating generates residual stresses and larger thermal curvatures in the cross-section.
- The internationally recognised and mostly used standard fire curve overestimates the fire effect in buildings with a low fire load (normal living spaces). In buildings with a high fire load (warehouses, libraries, etc.), higher temperatures may, however, occur. The standard fire curve basically describes the temperature curve from the onset of a fully developed fire in a building (after flashover).
- Natural fire curves may be defined by using Annex A/ B of SN EN 1991-1-2 or by using CFD simulation (Computational Fluid Dynamics).
- When calculating the thermal action, both the convective and the radiative component contribute to the net heat flux:
 - Convection is the transfer of heat by the physical movement of hot masses of air.
 - Radiation refers to the transfer of heat in energy waves from the flame or plume.
 Numerical comparisons have shown that especially in high spaces, where large hot gas layers are formed, the radiation of the flame or plume may be neglected. The radiative net heat flux is thus primarily relevant for members in the vicinity of the source of fire.

Learning objectives

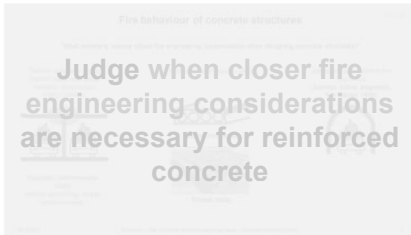

Describe the material behaviour under fire conditions

Describe the structural behaviour under fire conditions

Identify the most suitable verification method(s) for the fire design

Apply simplified design methods and understand their relation to design methods at ambient temperature

Understand the need for design verifications related to explosive spalling and use the appropriate measure to deal with it

Material behaviour under fire conditions

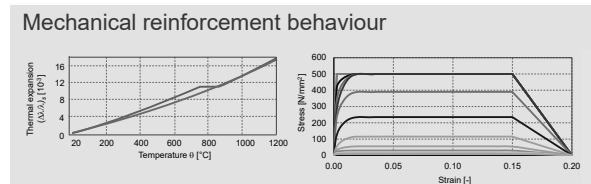
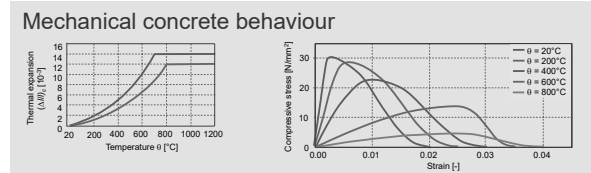
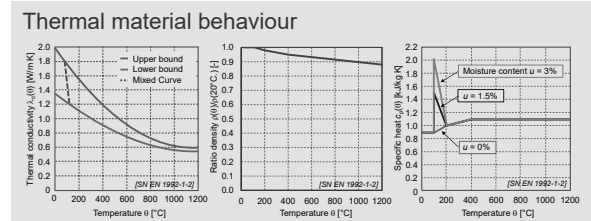
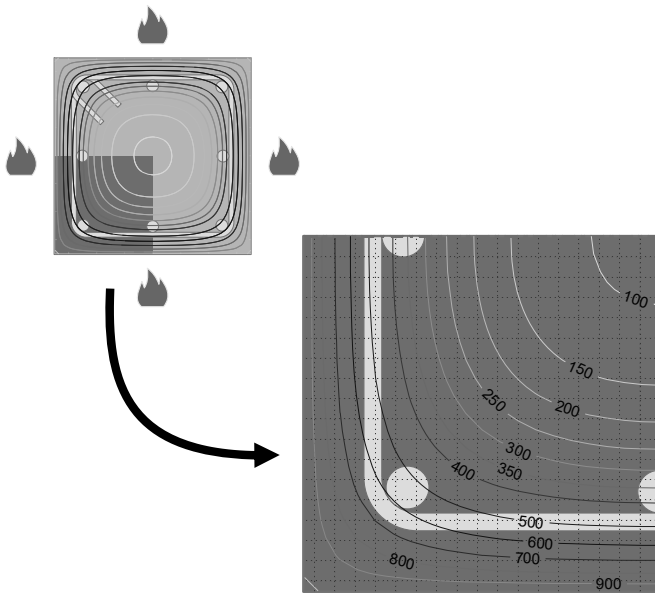

The material behaviour of reinforced concrete under the influence of fire is primarily characterised by the following phenomena:

- Thermal material behaviour (thermal conductivity, specific heat, density) due to increased temperature; Note: Concrete is heated comparably slowly (low thermal conductivity, high specific heat) and, therefore, protects the reinforcement from heating
- Mechanical material behaviour of concrete and reinforcement (elongation, strength, stiffness, creep, ...) due to increased temperature

The most important parameters in the fire design of concrete structures are generally the concrete cover and member thickness.

Material behaviour under fire conditions

Thermal behaviour of concrete

- Based on temperature-time curves $\theta_g(t)$, the thermal actions on members are calculated as heat flux.
- In a thermal analysis, the transient heat transfer in solids may be determined using Fourier's law:

$$\frac{\partial \theta}{\partial t} = \frac{\lambda}{\rho \cdot c_p} \cdot \left(\frac{\partial^2 \theta}{\partial x^2} + \frac{\partial^2 \theta}{\partial y^2} + \frac{\partial^2 \theta}{\partial z^2} \right),$$

where

θ	Temperature [K]
t	Time [s]
λ	Thermal conductivity [m ² /s]
ρ	Material density [kg/m ³]
c_p	Specific heat [J/(kgK)]
x, y, z	Coordinates [m]

Assumption:

The material properties λ , ρ and c_p depend only on the temperature, i.e. it is assumed that the solid consists of an isotropic material (this assumption is valid for reinforcing bar diameters < 50 mm).

Material behaviour under fire conditions

Thermal behaviour of concrete

- The thermal material laws from SN EN 1992-1-2 are based on experiments.
- SN EN 1992-1-2 presents material laws for siliceous and calcareous aggregates.

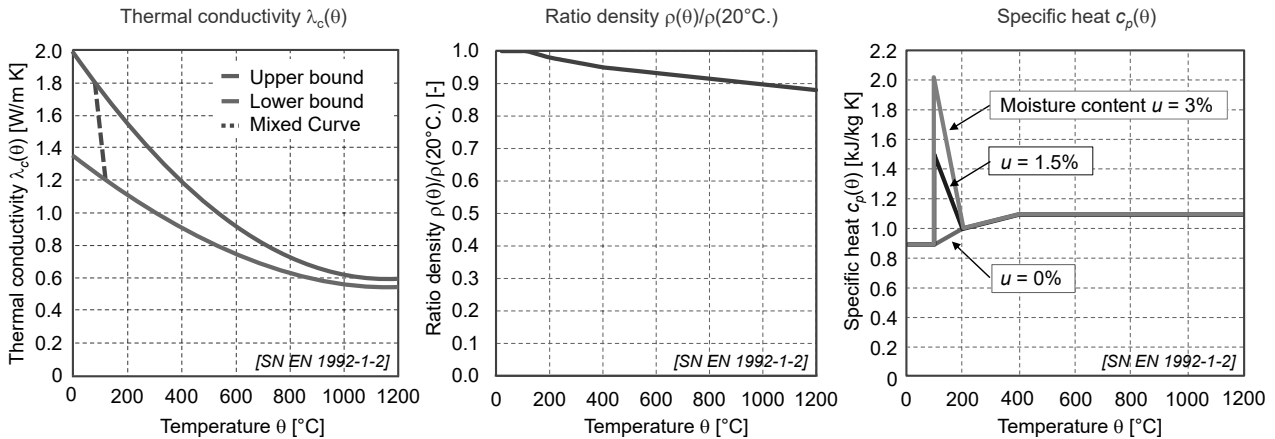

Thermal conductivity:

- The thermal conductivity describes the amount of heat exchanged through a member of 1 m thickness between two opposed surfaces of 1 m² each within one hour with a temperature difference of $\Delta\theta = 1$ K.
- The thermal conductivity of concrete is approximately 20 to 25 times lower than the thermal conductivity of steel.
- The thermal conductivity depends mainly on the porosity, the type of aggregate (light weight aggregate has a largely lower thermal conductivity than normal weight concrete), and the moisture content.
- The thermal conductivity of high strength concrete may be slightly higher than that of normal strength concrete. However, the application of the curves shown is also permissible for high strength concrete in accordance with SN EN 1992-1-2.
- SN EN 1992-1-2 specifies two curves (upper and lower limit) for determining the thermal conductivity of concrete. The choice of the upper or lower limit is an «NDP» (Nationally Determined Parameter). The parameter should, thus, be determined in the National Annex. In Switzerland, the upper limit is recommended.
- For the new Eurocode, EN 1992-1-2:202x, it is planned to specify a "mixed curve" as the only curve for thermal conductivity, valid for normal weight concrete with siliceous and calcareous aggregates as well as for high strength concrete.

Specific heat:

- The specific heat describes the ability of a material to store heat.
- For the specific heat c_p , the evaporation of the pore water in the temperature range of 100 - 200 °C is approximately taken into account by local peak values depending on the moisture content of the concrete.

Material behaviour under fire conditions

Structural behaviour, simply supported slab ►
Structural behaviour, two-span slab ►

Mechanical behaviour of concrete

- Concrete expands with increasing temperature.
- Compressive strength and modulus of elasticity of the concrete decrease at high temperatures.
- The tensile strength of the concrete also decreases (more than compressive strength).
- The decrease of strength and stiffness is highly sensitive to the type of aggregate used. SN EN 1992-1-2 gives curves for concrete with siliceous and calcareous aggregates and three curves for high-strength concrete.
- Although the descending branch (and especially the ultimate strain) of the constitutive relationships provided in SN EN 1992-1-1 and SN EN 1992-1-2 do not correspond, the results obtained within a standard sectional analysis are generally consistent.

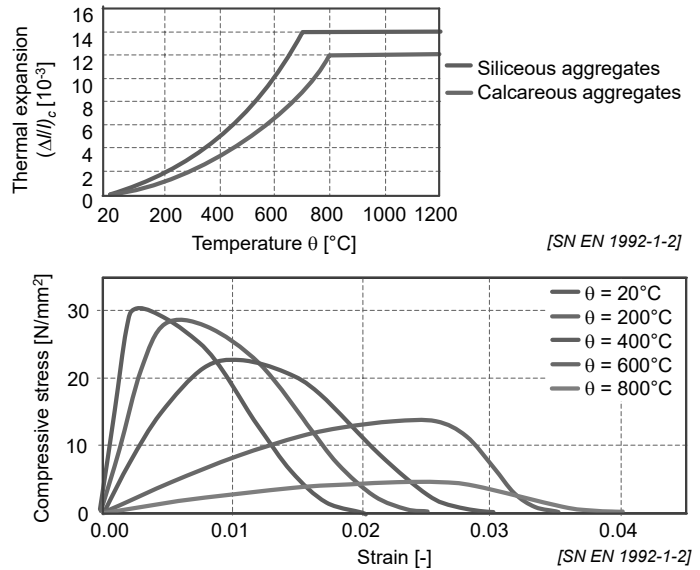

19.12.2023

ETH Zurich | Chair of Concrete Structures and Bridge Design | Advanced Structural Concrete

17

- The concrete composition changes when subjected to fire with the type of aggregates, but also with the cement content, the w/c ratio, the concrete age and the concrete moisture content. The main phenomena are:
 - Free water evaporates (\rightarrow shrinkage)
 - Water is drawn out from the cement paste (\rightarrow "accelerated drying shrinkage")
 - Aggregates expand (not all aggregates equally) (\rightarrow "(differential) expansion")

The integration of these effects cause "thermal expansion".

- The reduction of the compressive strength $f_{cd,\theta} / f_{cd,20^{\circ}\text{C}}$ is mainly influenced by the type of aggregates and mostly independent from other parameters as the cement content or the w/c ratio.
- SN EN 1992-1-2 provides constitutive stress-strain relationships for concrete with siliceous and calcareous aggregates and for high-strength concrete. In general, the more conservative curve (siliceous aggregates) should be selected for normal-strength concrete (the type of aggregate is usually not known during design).
- Input values for the calculation of the temperature-dependent stress-strain relationships for design are the characteristic values of the corresponding strength at ambient temperature (e.g. f_{ck}).
- Although the descending branch (and especially the ultimate strain) of the constitutive relationships provided in SN EN 1992-1-1 (may also be used for temperatures $< 100^{\circ}\text{C}$) and SN EN 1992-1-2 do not correspond (see graph below for C30/37), the results obtained within a standard sectional analysis based on well-known assumptions for ultimate limit design (like linearity of the strain profile on the section and perfect bond at the steel-concrete interface) by adopting the different constitutive relationships are generally consistent.
- For higher temperatures, concrete generally exhibits a rather high fracture energy in the unloading phase.

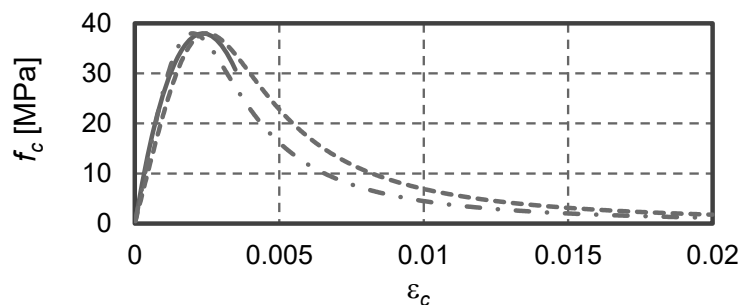

— EN 1992-1-1 - - - EN 1992-1-2 sil. ··· EN 1992-1-2 calc.

Material behaviour under fire conditions

Mechanical behaviour of concrete

- The load history significantly influences the material strength and stiffness (heating at constant load results in higher $f_{cd,t}$ than load increase at constant temperature).
- This effect is mainly due to the load induced thermal strains (= LITS).
- LITS occur under load in the first heating phase and are largely irreversible.
- LITS up to about 400°C are attributed to chemical reactions and microstructural changes in the cement matrix (e.g. dehydration, drying out and rearrangement of water molecules in the cement matrix).
- At higher temperatures, mainly the thermal incompatibility of the cement matrix and aggregates is assumed to generate LITS.
- The material law given in SN EN 1992-1-2 implicitly includes effects from creep strain and transient state strain developed during heating.

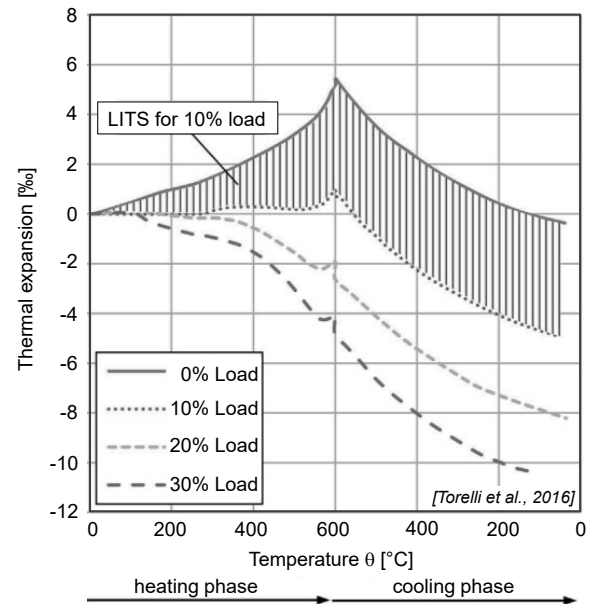

- The occurrence of load induced thermal strains is advantageous for hyperstatic structures or members subjected to compressive stress, as it "counteracts" the axial thermal expansion and compensates for compressive stress peaks.
- In the cooling/ unloading phase, cracks may form as a result of irreversible load induced thermal strains.

Mechanical behaviour of reinforcing and prestressing steel

- Steel expands as the temperature rises.
- The strength and modulus of elasticity of reinforcing and prestressing steel decrease at high temperatures.
- SN EN 1992-1-2 gives curves for "hot rolled" (with distinct yield plateau at ambient temperature) and "cold worked" reinforcing steel (shown: hot rolled reinforcing steel).
- SN EN 1992-1-2 gives two classes for reinforcing steel (class N and class X). Generally (also in Switzerland), class N should be used.
- SN EN 1992-1-2 gives two classes for prestressing steel (class A and class B). In Switzerland, class A should be used.

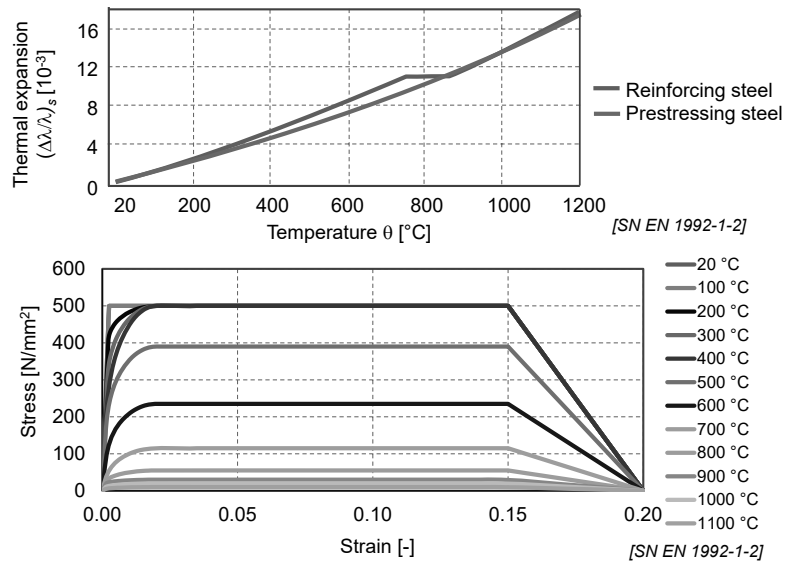

- Input values for the calculation of the temperature-dependent stress-strain relationships for design purposes are the characteristic values of the controlling strengths at normal temperature f_{sk} (in SN EN 1992-1-2 f_{yk}). In the case of prestressing steel, the value $0.9 f_{pk}$ is used due to the absence of a pronounced yield strength.
- For reinforcing steel, 500°C is considered as the critical temperature (400°C for prestressing bars and 350°C for prestressing strands and wires).
- Reinforcing steel actually provides a strain hardening phase up to around 400°C (with ultimate strain equal or lower than at ambient temperature), but not at higher temperatures. However, no constitutive stress-strain relationship is given to account for this material behaviour.
- "hot rolled" reinforcing steel (detailed description of production process: "hot rolled quenched and self tempered (QST)") exhibits a distinct yield plateau whereas "cold worked" (hot rolled and cold stretched) does not.
- It may be assumed that for a reinforcement steel of ductility class B500A the relationship for "cold worked" applies, for a reinforcement steel of ductility class B500B both relationships are possible (diameters >20 mm are usually hot rolled) and for a reinforcement steel of ductility class B500C the relationship "hot rolled" applies.
- The decreasing branch is mainly given for the purpose of stable numerical analyses.

Learning objectives

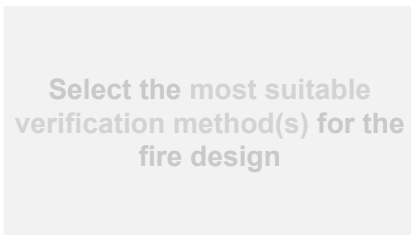
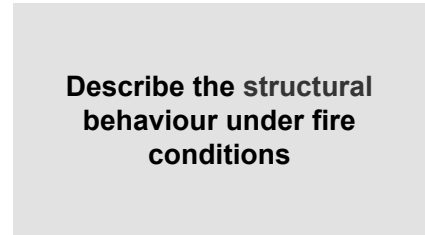
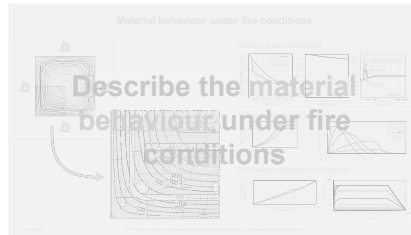
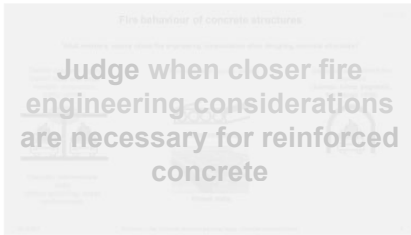

Structural behaviour under fire conditions

Member analysis

- Member behaviour independent of the structure
- Simple
- Standard analysis for fire design

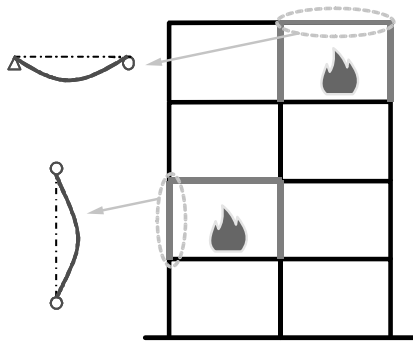

[ECSC project DIFISEK]

Global structural analysis

- Interaction between structural members
- Function of concerned compartment / part of the structure
- Global stability

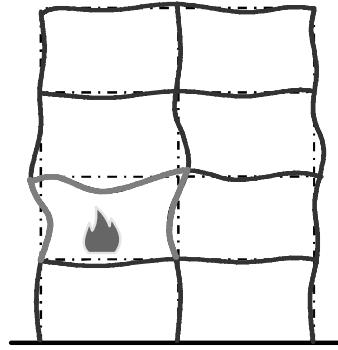

[ECSC project DIFISEK]

Structural behaviour under fire conditions

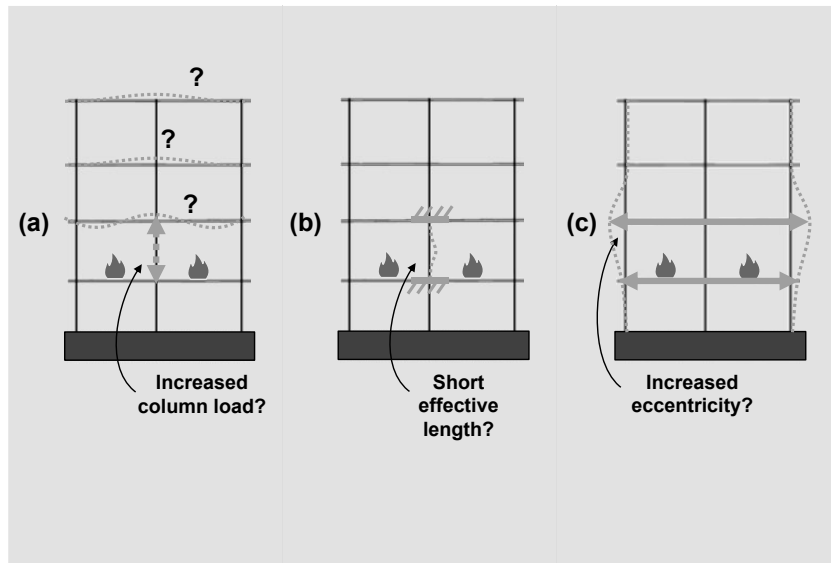
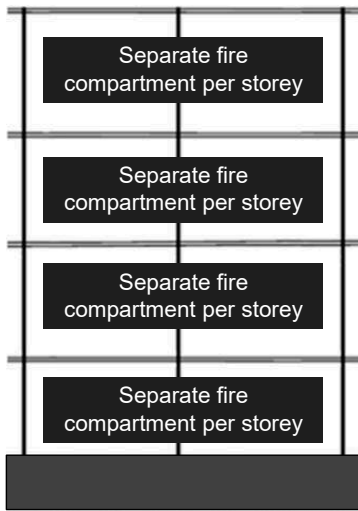

Structural behaviour under fire conditions

Member expansion and restraint action: Column test on composite column by F.J. Aschwanden AG

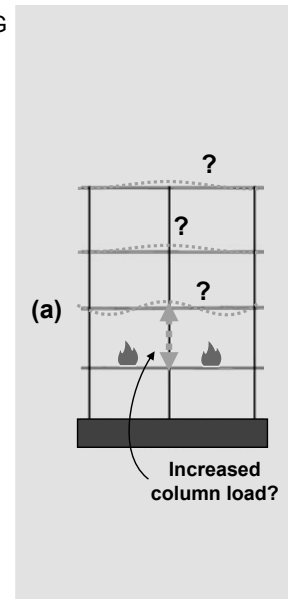
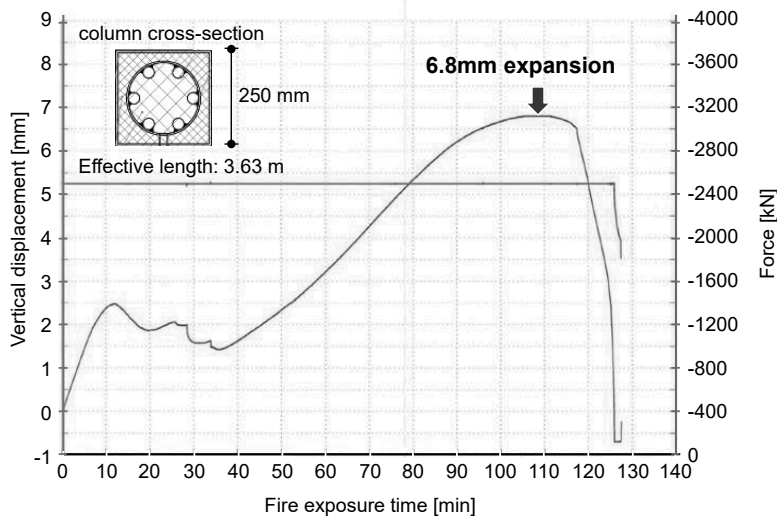

19.12.2023

ETH Zurich | Chair of Concrete Structures and Bridge Design | Advanced Structural Concrete

24

Inconsistent code provisions:

- SIA 262: Structures shall be designed such that restrained and unrestrained deformations due to fire do not lead to premature failure.
- SN EN 1992-1-2, 2.4.1 (3):
The structural analysis [...]
Note: For verifying standard fire resistance requirements, a member analysis is sufficient.
- SN EN 1992-1-2, 2.4.2 (4):
Only the effects of thermal deformations resulting from thermal gradients across the cross-section need to be considered. The effects of axial or in-plane thermal expansions may be neglected.

If the elongation in the order of 6.8 mm is completely restrained in the axial direction (e.g. by a stiff wall above and below the column within a fire compartment), it may cause a considerable increase of the acting load (attention: increased punching shear load).

Example:

Square reinforced composite column with cross-sectional dimensions 250 mm x 250 mm and length 3630 mm (see slide)

- Thermal effect: Standard fire curve
- Completely restrained in axial direction (extreme consideration)
- Stiffness EA after 110 min: cross-section divided into finite elements, integrated temperature-dependent stiffness for all elements
- Assumption: no spalling
- Increased support load:

$$\Delta L = \frac{\Delta N}{EA} \cdot L$$

$$\Rightarrow \Delta N = \frac{\Delta L}{L} \cdot EA = \frac{6.8 \text{ mm}}{3630 \text{ mm}} \cdot 1600 \text{ MN} \approx 3000 \text{ kN}$$

- However, the elongation is usually considered to be compensated by LITS.

Structural behaviour under fire conditions

Effective length under fire conditions:

SN EN 1992-1-2 5.3.2 (2):

The effective length of a column under fire conditions $l_{0,fi}$ may be assumed to be equal to l_0 at normal temperature in all cases.

For braced building structures where the required Standard fire exposure is higher than 30 minutes, the effective length $l_{0,fi}$ may be taken as $0.5 l$ for intermediate floors, where l is the actual length of the column (centre to centre).

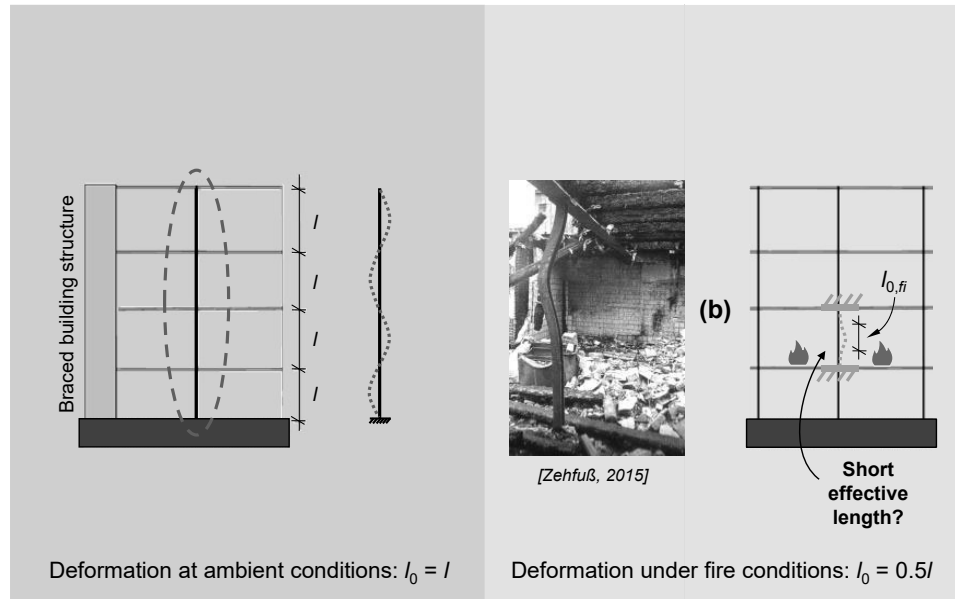

- Assuming that fire occurs only in one fire compartment/storey, a reduced buckling length / altered boundary conditions may be used according to SN EN 1992-1-2 for the columns in case of fire exposure (supposing a partial bending restraint by floor slabs and columns not exposed to fire in slabs above/below).
- It is, however, recommended to apply this simplification with sufficient engineering judgement, as overly stiff boundary conditions may lead to increased loading during fire exposure.

Structural behaviour under fire conditions

Effective length under fire conditions:

SN EN 1992-1-2 5.3.2 (2):

The effective length of a column under fire conditions $l_{0,fi}$ may be assumed to be equal to l_0 at normal temperature in all cases.

For braced building structures where the required Standard fire exposure is higher than 30 minutes, the effective length $l_{0,fi}$ may be taken $0.5l \leq l_{0,fi} \leq 0.7l$ for the upper floor, where l is the actual length of the column (centre to centre).

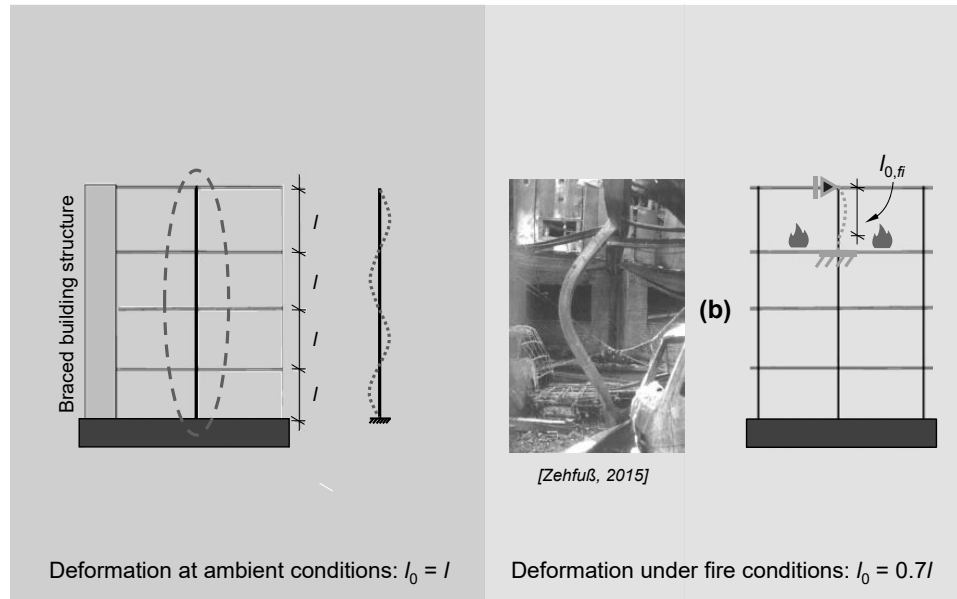

Structural behaviour under fire conditions

Member expansion: Cardington tests, 2001

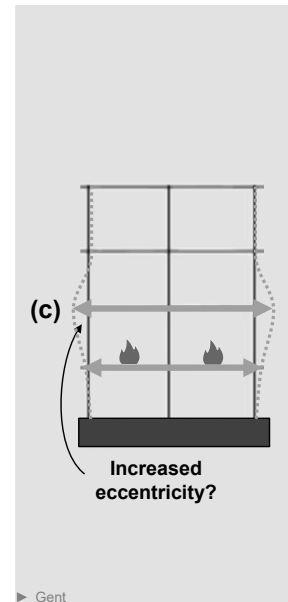
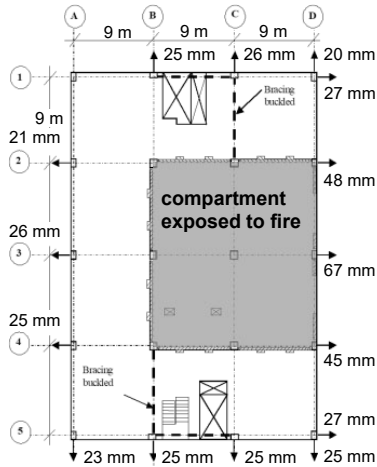

19.12.2023

ETH Zurich | Chair of Concrete Structures and Bridge Design | Advanced Structural Concrete

27

A large scale fire test was carried out at the Building Research Establishment's Cardington laboratory in the UK in 2001. The test took place on the ground floor of the seven-storey concrete frame which formed the European Concrete Building Project (ECBP). The floor was supported by a number of columns consisting of high performance concrete (C85) containing polypropylene fibres to reduce the susceptibility to explosive spalling at high temperatures.

Lateral movements due to thermal expansion and the development of compressive forces in the slab, where extensive surface spalling had occurred, were observed. The residual displacement of the edge columns in the building was recorded the following day as illustrated above (left). The deformation can be seen above (middle). The edge columns at the first floor level were pushed out by the expansion of the floor slab causing buckling of the steel bracing members as shown above (right). However, no collapse of any of the columns occurred.

This information is taken from: Lennon T., Bailey C. and Clayton N., The Performance of High Grade Concrete Columns in Fire, 6th International Symposium on High Strength/High Performance Concrete, Leipzig, 2002.

Structural behaviour under fire conditions

What members require closer fire engineering consideration when designing concrete structures?

Slender columns/ highly loaded walls with small member dimensions (HPC/ UHPC)

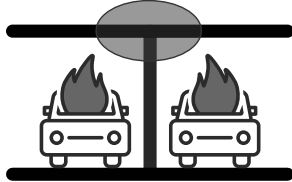

Statically indeterminate slabs without (punching) shear reinforcement

Members with slender webs



Hollow core slabs



Ribbed slabs

Members with intense fire exposure (tunnels/ tunnel segments, fire ratings >R90)



Structural behaviour under fire conditions

Member expansion and restraint action: Brandversuche Lehrte, 1978

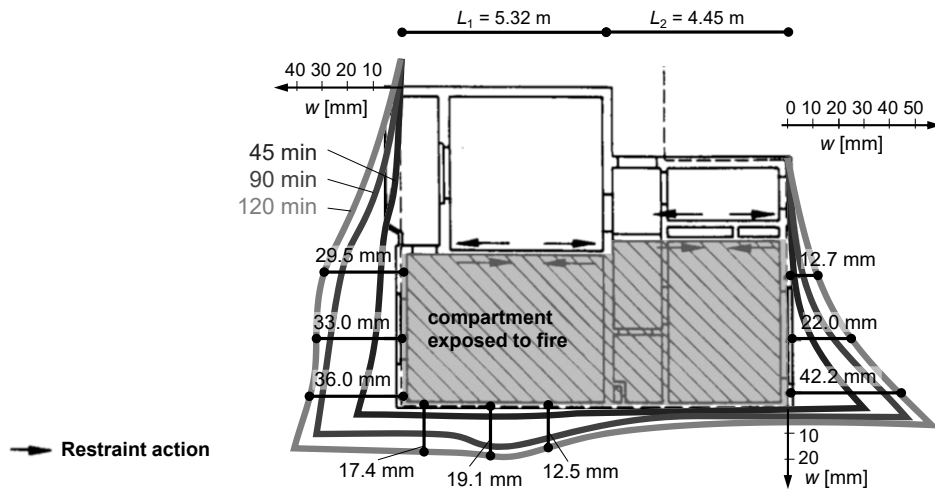

[Bechtold et al., 1978]

Cracking was observed in the tests, however, no failure occurred.

Structural behaviour under fire conditions

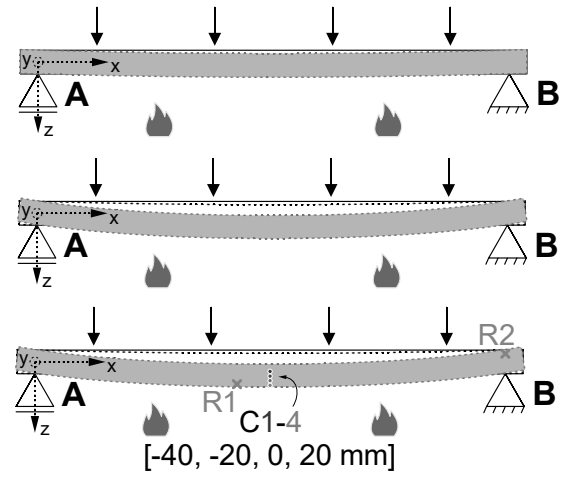
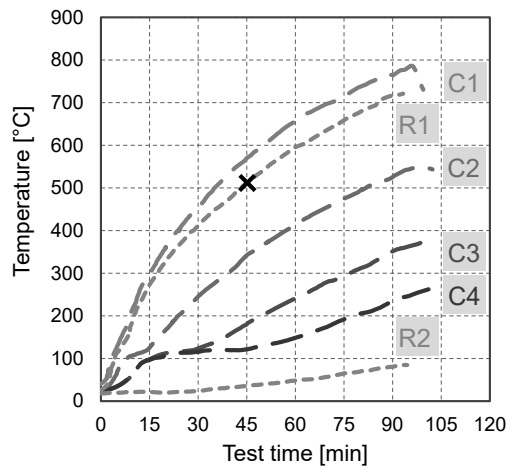

Structural behaviour under fire conditions

Restraint moments: Tests on slender continuous slab strips carried out by Kordina and Wesche, 1979

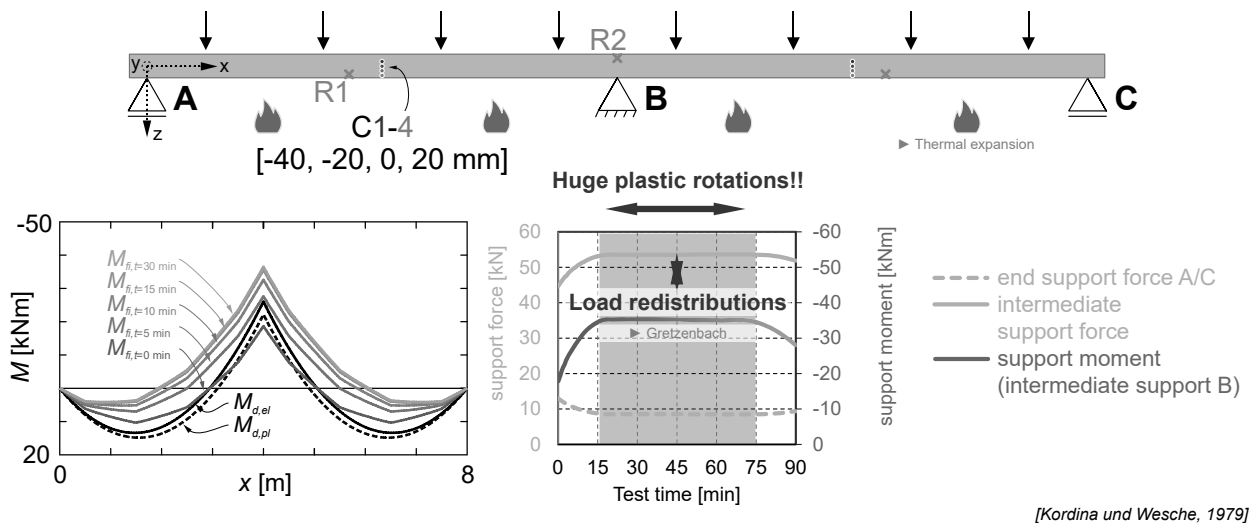

Kordina and Wesche (1979) carried out 10 fire tests on different one-way slabs of 8 m length incorporating different reinforcement contents, different reinforcing layouts (prefabricated net reinforcement, bar reinforcement), different reinforcement ductility classes, different concrete covers, different construction methods (partial prefabrication, cast in-situ) and different slab heights. The standard fire curve was applied in all tests. The tests were intensively instrumented and well documented. Several slabs failed due to insufficient rotation capacity.

This test series as well as recent analytical analysis [Bischof et al.] showed:

- In statically indeterminate systems exposed to fire, high restraint moments with corresponding plastic rotations occur (far beyond limits at ambient temperature).
- In very short time of fire exposure, rotation capacity is required if support conditions do not allow for activating a membrane action.

The tabulated design data of SIA 262 (Table 16) and SN EN 1992-1-2 (Table 5.8) defines rather small minimum dimensions for slabs. This is mainly because membrane action is activated in slabs of reinforced concrete structures.

Structural behaviour under fire conditions

Restraint moments: Tunnels

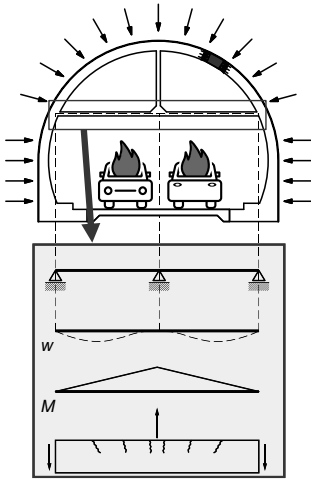

Suspended ceiling with severe damages over a length of around 230 m

Structural behaviour under fire conditions

Restraint moments: Detailing

Provisions in SN EN 1992-1-2

- For continuous beams or slabs (Figure 5.6, right): increased anchorage length of top reinforcement
- Minimum top reinforcement degree of 0.5% at intermediate supports if:
 - Ductility class A
 - One-way continuous slabs
- For flat slabs: continuous minimum reinforcement over the full span of 20% of the total top reinforcement over intermediate supports required by ambient temperature ULS design in each direction.

!! Do not use Annex E for moment redistributions

Additional provision in prEN 1992-1-2

- Increased shear loads to be considered if stirrups with more than two legs are used

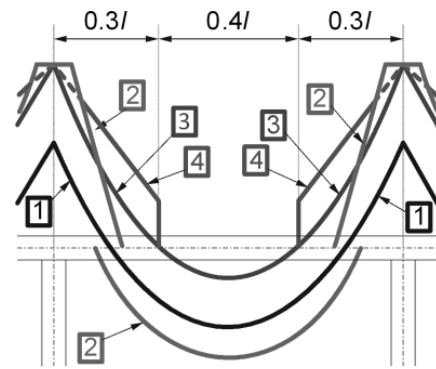

► Kordina & Wesche

- (1) Diagram of bending moments for the actions in a fire situation ($E_{a,t}$) at $t = 0$
- (2) Envelope of required resistance of tensile reinforcement for design at ambient conditions
- (3) Diagram of bending moments in fire conditions including restraint moments due to thermal curvature of members
- (4) Envelope of requested resistance of tensile reinforcement according to Formula (9.1) in SN EN 1992-1-2

Structural behaviour under fire conditions

What members require closer fire engineering consideration when designing concrete structures?

Slender columns/ highly loaded walls with small member dimensions (HPC/ UHPC)

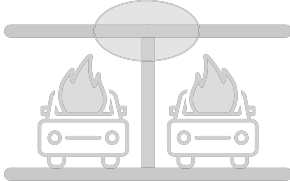

Statically indeterminate slabs without (punching) shear reinforcement

Members with slender webs



Hollow core slabs

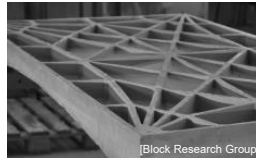

Ribbed slabs

Members with intense fire exposure (tunnels/ tunnel segments, fire ratings >R90)



Structural behaviour under fire conditions

Members with slender webs

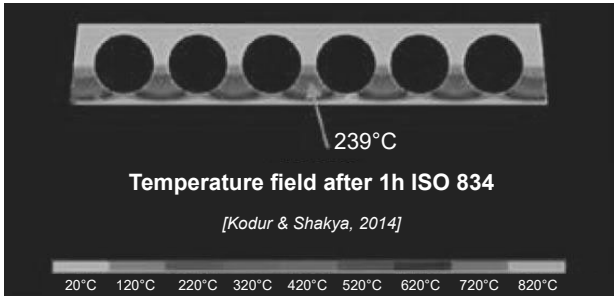

Fire in underground parking, Rotterdam (2007)

- Anchorage zones (pretensioning reinforcement), supports, cavities, dapped ends, slender webs, etc. may be critical under fire conditions. They require good detailing!

Structural behaviour under fire conditions

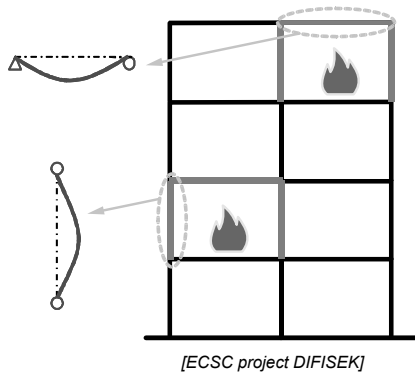

Design recommendations for fire design

- Member analysis with awareness of structural behaviour
- Axially restrained support conditions in the axial direction are usually favourable for beams or slabs (membrane or catenary action) but may, in rare cases, be unfavourable for members where stability failure occurs (such as columns or walls).
- Column design:
 - Definition of N_{Ed} with some reserve in case of stiff boundary conditions
 - No “blind” reduction of the effective length of a column under fire conditions
 - Rough estimation of column eccentricity due to thermal expansion of slab
- Slab / beam design:
 - Use of $m_d/m_{Rd} = 1$ (ULS design) for slabs without shear/punching reinforcement.
 - Consideration of detailing rules in SN EN 1992-1-2.

Learning objectives

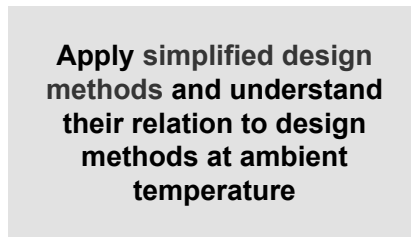
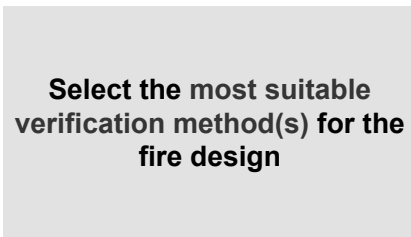
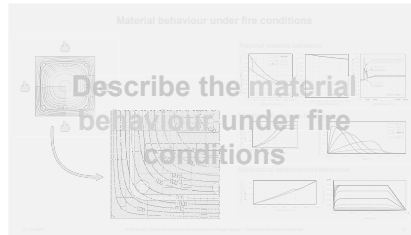
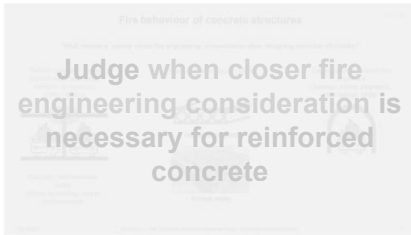

Design and structural analysis

- Fire is an accidental design situation. Thus, the fire design/ structural analysis is carried out with reduced partial safety factors (see slide 12 for actions).
 - Design values of mechanical material properties for the fire situation are equivalent to the characteristic values (used for simplified design methods and advanced design methods) :
 - Concrete: e.g. $f_{c,0} = k_c f_{ck} \gamma_{M,fi}$, with $\gamma_{M,fi} = 1$
 - Reinforcement: e.g. $f_{sy,0} = k_s f_{sy} \gamma_{M,fi}$, with $\gamma_{M,fi} = 1$
 - In principle, SN EN 1992-1-2 provides four levels of approximation in design:
 - Level 1: Verification with tabulated design data
 - Level 2: Verification with simplified design methods (cross-sectional resistance)
 - Level 3: Verification by the advanced design methods (FEM)
 - Level 4: Verification by experiments
-
- The choice of the appropriate method depends on the required information and the required model accuracy.
 - The tables and design models from SN EN 1992-1-2 are based on the assumption of the standard fire curve. For other fire curves, advanced design methods should be used.

19.12.2023

ETH Zurich | Chair of Concrete Structures and Bridge Design | Advanced Structural Concrete

38

	Tabulated data	Simplified design methods	Advanced design methods
Member analysis The member is considered as isolated. Indirect fire actions are not considered, except those resulting from thermal gradients.	Yes <ul style="list-style-type: none"> - Data given for standard fire only - In principle data could be developed for other fire curves 	Yes <ul style="list-style-type: none"> - Standard and parametric fires - temperature profiles given for standard fire only - material models apply only to heating rates similar to standard fire. 	Yes Only the principles are given
Analysis of parts of the structure Analysis of parts of the structure Indirect fire actions within the subassembly are considered, but no time-dependent interaction with other parts of the structure.	No	Yes <ul style="list-style-type: none"> - Standard and parametric fires - temperature profiles given for standard fire only - material models apply only to heating rates similar to standard fire. 	Yes Only the principles are given
Global structural analysis Analysis of the entire structure. Indirect fire actions are considered throughout the structure.	No	No	Yes Only the principles are given

Design and structural analysis

Verification with tabulated design data according to SIA 262

- Minimum dimensions and concrete covers for different members for all fire resistance classes
- Tabulated design data is based on experiments (and a certain amount of extrapolation)
- Example: Table 16 from SIA 262:

Fire resistance class	Minimum cover of reinforcement [mm]	Minimum member dimensions [mm]					
		Columns	Walls	Slabs	Mushroom slabs	Flat slabs	Beam web width
R 30	20	150	120	60	150	80	100
R 60	20	200	140	80	150	200	150
R 90	30	240	170	100	150	200	200
R 120	30	280	220	120	150	200	200
R 180	40	360	300	150	200	200	400

NB1: the application of Table 16 for columns is generally limited to R 180 and for columns additionally to slenderness $\lambda \leq 50$ for R 90 and $\lambda \leq 30$ for R 120.

NB2: Table 5.2a (columns) of SN EN 1992-1-2 defining minimum member dimensions and axis distances ($c_{nom} + \varnothing_{stirrups} + \varnothing_{longitudinal}/2$) is more conservative than Table 16 of SIA 262, mainly because it can be used up to $l_0 = 6$ m.

- prEN 1992-1-2:2019: Tabulated design data may be used to obtain recognised design solutions generally in relation to section typology (dimensions, axis distance, reinforcement ratio etc.) without recourse to any form of equilibrium equation. Tabulated data may be derived from tests, calculation models, or some combination of the two.
- The verification with tabulated design data makes use of thermal protection of concrete cover for the reinforcement (reference to critical temperature).
- R30 can be guaranteed with concrete covers < 20 mm (existing structures!). These values are not given in Table 16 as they are not permitted in the design for new buildings due to durability/ bond reasons.
- It can be seen from the values of tabulated design data that the cover required anyway for other reasons (durability, bond) is sufficient in most cases to guarantee sufficient fire safety (fire resistance duration).
- For prestressing steel, the minimum concrete covers given in Table 16 must be increased by 15 mm because the critical temperature for prestressing steel is lower than for reinforcing steel.
- SN EN 1992-1-2 defines minimum axis distances (distance from surface to centre of the reinforcement) instead of concrete cover. This is more consistent because the temperature of reinforcement is governed by the distance of its centre to the fire exposed surface (and not by the distance of its edge to the fire exposed surface). In SIA 262, cover is given for ease of use reasons, as this is the common value used (for durability).

Design and structural analysis

Verification with tabulated design data according to SN EN 1992-1-2

- Tabulated design data for normal strength columns, walls, beams and slabs defining minimum dimensions and axis distances in Section 5
- Tabulated data based on experiments (and a certain amount of extrapolation)
- Example shown (right): Table 5.5 from SN EN 1992-1-2
- Several tables for verifying columns:
 - Method A: Table 5.2a and Formula 5.7 (see next slide):
To be used only for $l_{0,fl} = 0.5l_0$
Exception: Expertise documents
 - Method B: Application not recommended
 - Annex C: Amendment 2019 may be used.

Table 5.5: Minimum dimensions and axis distances for simply supported beams made with reinforced and prestressed concrete

Standard fire resistance	Minimum dimensions (mm)						
	Possible combinations of a and b_{min} where a is the average axis distance and b_{min} is the width of beam				Web thickness b_w		
					Class WA	Class WB	Class WC
1	2	3	4	5	6	7	8
R 30	$b_{min}= 80$ $a = 25$	120 20	160 15*	200 15*	80	80	80
R 60	$b_{min}= 120$ $a = 40$	160 35	200 30	300 25	100	80	100
R 90	$b_{min}= 150$ $a = 55$	200 45	300 40	400 35	110	100	100
R 120	$b_{min}= 200$ $a = 65$	240 60	300 55	500 50	130	120	120
R 180	$b_{min}= 240$ $a = 80$	300 70	400 65	600 60	150	150	140
R 240	$b_{min}= 280$ $a = 90$	350 80	500 75	700 70	170	170	160
$a_{ed} = a + 10\text{mm}$ (see note below)							
For prestressed beams the increase of axis distance according to 5.2(5) should be noted.							
a_{ed} is the axis distance to the side of beam for the corner bars (or tendon or wire) of beams with only one layer of reinforcement. For values of b_{min} greater than that given in Column 4 no increase of a_{ed} is required.							
* Normally the cover required by EN 1992-1-1 will control.							

- In principle, when using tables in accordance with SN EN 1992-1-2, no verification for explosive spalling is required.
- SN EN 1992-1-2 leaves a certain room for interpretation in the consideration of explosive spalling when applying the tables (free application according to section 5.1(4) or restriction to normal-strength concrete according to section 4.5.1(4)). However, tables were derived with tests in which only normal-strength concrete was used. Accordingly, the use of the tables for high-strength concretes without minimising the probability of occurrence of explosive spalling is not recommended.
- Theoretically, the tabulated design data may also be used for high strength concrete in accordance with section 6.4.3 of SN EN 1992-1-2. However, the cross-section dimensions must be increased accordingly.

Design and structural analysis

Verification with tabulated design data according to SN EN 1992-1-2

- For columns, Method A is available in the normative part of SN EN 1992-1-2.
- Method A is very simple, completely empirical but provides (mostly) conservative results for $l_{0,fi} = 0.5l_0$. The fire resistance duration is calculated as follows (equation 5.7):

$$R = 120 \left(\left(R_{\eta,fi} + R_a + R_l + R_b + R_n \right) / 120 \right)^{1.8}$$

- Parameters: Load utilisation ($R_{\eta,fi}$), axis distance (R_a), buckling length (R_l), cross-sectional dimension (R_b), number of reinforcing bars placed in the corner of the cross-section (R_n)
- Limits of application:
 - First order of eccentricity $e_1 = M_{0Ed,fi} / N_{0Ed,fi} \leq e_{max} = 0.15 h$
 - Axis distance $25 \text{ mm} \leq a \leq 80 \text{ mm}$
 - Equivalent length in case of fire $l_{0,fi} \leq 3 \text{ m}$
 - Reinforcement $A_s < 0.04 A_c$
 - Rectangular columns: $200 \text{ mm} \leq b' = 2A_c/(b+h)$, circular columns: $\varnothing \leq 450 \text{ mm}$ ($h \leq 1.5b$)

- Method A was developed in Belgium and is based on the evaluation of a total of 80 tests of loaded column exposed to the standard fire curve. The column tests were carried out in four different research institutions.
- Since 2013, Swiss precast companies have been carrying out extensive experimental campaigns on high strength precast columns subjected to fire. Detailed numerical evaluations and comparison calculations of these campaigns show that, with some limitations, Method A also leads to a safe design outside its limits of application (see corresponding expertise documents).

Design and structural analysis

Verification with simplified design methods according to SN EN 1992-1-2 (cross-sectional resistance)

- Existing methods in SN EN 1992-1-2 :
 - Annex B.1 (informative): 500°C Isotherm Method, application not permitted in Switzerland
 - Annex B.2 (informative): Zone Method, application permitted in Switzerland for bending verification
 - Annex B.3 (informative): Method for assessment of a reinforced concrete cross-section exposed to bending moment and axial load by the method based on estimation of curvature), application permitted in Switzerland
 - Annex D (informative): Calculation methods for shear, torsion and anchorage of reinforcement
 - Annex E (informative): Simplified calculation methods for beams and slabs, application not permitted in Switzerland

Bending	Bending and axial load	Shear
Annex B.1 Annex B.2	Annex B.1 Annex B.2	Annex D (additional information required, see prEN 1992-1-2)
Annex E	Annex B.3	
	Refined Zone Method (new Annex C)	

- When using simplified design methods according to SN EN 1992-1-2, explosive spalling should be avoided.
- For the Refined Zone Method, the current Annex B.2 was corrected (e.g. determination of a_z , which is based on ENV provisions) and further refined with missing information (e.g. for verifying members subjected to second order effects) where necessary. The Refined Zone Method was used to establish the amended Annex C (2019) of SN EN 1992-1-2.
- The methods presented in Annex B.1 and B.2 as well as the Refined Zone Method approximate the reduced concrete strength due to fire by determining a temperature-dependent reduction of the concrete cross-section.
- In SN EN 1992-1-2, the application of Annex E is limited to distributed loads.
- Method B.3 is not presented here in more detail. It is basically a “simplified advanced design method” and requires a rather extensive computational effort (hand calculation not possible). When using it, it should be noted that thermal strains must be taken into account (even if not explicitly mentioned in SN EN 1992-1-2).
- For the verification of beams and slabs (bending and shear), all methods are quick to be used and generally yield safe results. For the verification of bending and axial load, only the methodology from Annex B.3 and the Refined Zone Method lead to safe results (→ Annex B.1 and Annex B.2 should not be used for the verification of bending and axial load).
- In prEN 1992-1-2:2019-10, the number of applicable methods is reduced. For the verification of bending, the methodology of Annex E may usually be applied (in rare cases, the Refined Zone Method may be applied). For the verification of bending and axial load, the Refined Zone Method may be applied (alternatively, the methodology of Annex B.3 may be applied).

Design and structural analysis

Verification with simplified design methods according to SN EN 1992-1-2 (cross-sectional resistance)

1. Thermal analysis

- a. Annex A (Isotherms) of SN EN 1992-1-2
- b. Simplified design method (available in SN EN 1992-1-2:202x)
- c. Advanced design method (FEM)

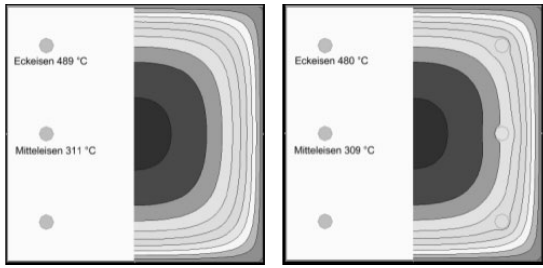

Temperature profile after 90 minutes of fire without consideration of reinforcement

Temperature profile after 90 minutes of fire with consideration of reinforcement [Infograph]

2. Mechanical analysis

Principle:

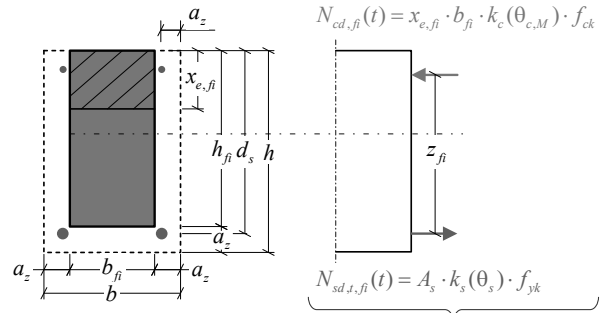

$$\gamma_{c,fi} = \gamma_{s,fi} = 1$$

$$N_{cd,fi}(t) = x_{e,fi} \cdot b_{fi} \cdot k_c(\theta_{c,M}) \cdot f_{ck}$$

$$N_{sd,t,fi}(t) = A_s \cdot k_s(\theta_s) \cdot f_{yk}$$

Verification:

$$M_{R,fi,d} = N_{sd,t,fi} \cdot z_{fi} \geq M_{E,fi,d}$$

- The SIA refers to SN EN 1992-1-2, note: mixing of standards is not permitted!
- In the thermal analysis, reinforcing bars may generally be neglected according to SN EN 1992-1-2.
- According to Section 4.5.1(5) of SN EN 1992-1-2, explosive spalling in the design could be simplified by "estimating the local loss of concrete cover to a reinforcement bar or bundle in cross-section and then checking the *reduced* bearing capacity of the section".

Design and structural analysis

Verification with simplified design methods according to SN EN 1992-1-2 (cross-sectional resistance)

1. Thermal analysis

b. Simplified design method (available in future in EN 1992-1-2:202x)

Formulae for temperature profile for checking the load-bearing capacity in the event of fire (function R)

$$\theta_1 = 345^\circ\text{C} \cdot \log\left(\frac{7(R_{fi} - 720 \text{ s})}{60 \text{ s}} + 1\right) \cdot e^{-y \sqrt{\frac{0.9k}{R_{fi}}}} \text{ or } 345^\circ\text{C} \cdot \log\left(\frac{7(R_{fi} - 720 \text{ s})}{60 \text{ s}} + 1\right) \cdot e^{-z \sqrt{\frac{0.9k}{R_{fi}}}}$$

t = duration of the standard fire (in seconds)

y resp. z = distance from the exposed surface (in m)

$$k = \rho \cdot c_p / \lambda = 3.3 \cdot 10^6 \text{ s/m}^2$$

member exposed on one side: $\theta = \theta_1(y \text{ resp. } z, t) + 20^\circ\text{C}$

member exposed on two sides: $\theta_2 = \theta_1(y \text{ resp. } z, t) + \theta_1(b - y \text{ resp. } h - z, t) + 20^\circ\text{C}$

b and h : member dimensions

member exposed on four sides: $\theta_4 = \theta_2(y, t) + \theta_2(z, t) + \frac{\theta_2(y, t) \cdot \theta_2(z, t)}{\theta_0(0, t)} + \left(345^\circ\text{C} \cdot \log\left(\frac{8t}{60 \text{ s}} + 1\right) - \theta_0(0, t)\right) \cdot \frac{(a_c - y') \cdot (a_c - z')}{a_c^2} + 20^\circ\text{C}$

$$a_c = 0.04 \text{ m for } R_{fi} \leq 60 \text{ min}$$

$$a_c = 0.10 \text{ m for } R_{fi} > 60 \text{ min}$$

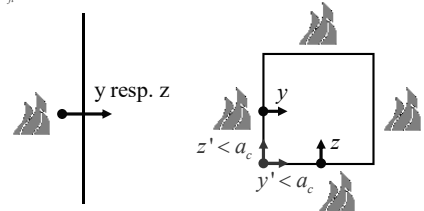

- The approximate formulae are based on the following assumptions:
 - Density of concrete according to SN EN 1992-1-2, reference value at 20°C: 2300 kg/m³
 - Specific heat according to SN EN 1992-1-2 with a moisture content of $k = 1.5\%$. The results are conservative for $k > 1.5\%$.
 - Thermal conductivity according to prEN 1992-1-2:2019-10 ("mixed curve")
 - Emissivity related to the concrete surface corresponds to 0.7
 - Convection factor corresponds to 25 W/(m²·K)
 - The formulae may be used if the minimum thickness exceeds the minimum values given in the following Table as a function of the standard fire resistance
- | Fire resistance R_{fi} | 30 | 60 | 90 | 120 | 180 | 240 |
|---|----|----|-----|-----|-----|-----|
| Minimum dimension of one-side exposed concrete member | 60 | 70 | 100 | 120 | 150 | 200 |
- The formulae are not yet formally approved. However, they may be useful as an approximate plausibility check of FE results.

Design and structural analysis

Verification with simplified design methods according to SN EN 1992-1-2 (cross-sectional resistance)

2. Mechanical analysis for *beams/ slabs*

1. Determination of the width of the rim zone a_z (use Figure B.5)
2. Determination of a reduced width and height of the cross-section by excluding the rim zone a_z
3. Determination of the reduction of the concrete compression strength (use Figure B.5a) with only one zone $\rightarrow \theta_M =$ Temperature in the centre of the cross-section)
4. Determination of the reduced strength of each reinforcing bar based on its temperature (see next slide).
5. Determination of the ultimate load-bearing capacity and verification of the fire design assuming a rectangular concrete compression stress block according to EN 1992-1-1:
 - $x_{e,ff} = x_{sb} = 0.8x$
 - $\epsilon_{cu} = 3.5\text{‰}$

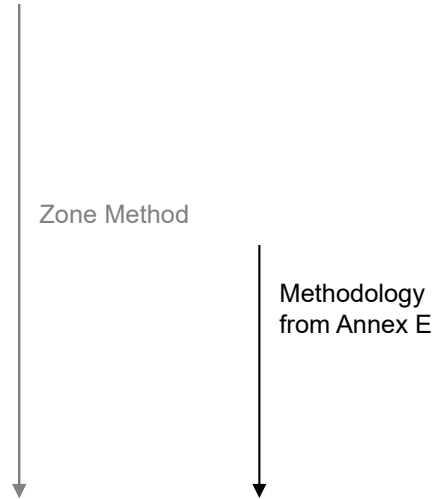

- In SN EN 1992-1-2, the zone outside the reduced cross-section due to fire exposure with width a_z is designated as “damaged zone”. This expression may be misleading when assuming that reinforcement within that zone should not be considered. This is, however, not the idea of the model to approach the actual material behaviour during a fire. Hence, the “damaged zone” is designated as “rim zone” in this document.
- The methodology from Annex E allows a very simple and quick design of beams and slabs of which the tension zone is exposed to fire. Even though the methodology consistently leads to unconservative results in comparison to other design methods (simplified or advanced) because the strength reduction of the compression zone is not considered, it leads to acceptably safe design if the depth of the concrete compression zone is limited in its height ($x/d < 0.25$).

Design and structural analysis

Verification with simplified design methods according to SN EN 1992-1-2 (cross-sectional resistance)

2. Mechanical analysis for *beams / slabs / columns*

1. ...
2. ...
3. ...

4. Determination of the reduced strength of each reinforcing bar (with SN EN 1992-1-2, 4.2.4.3)

- Curve 1 and 2 (hot rolled and cold worked reinforcing steel, respectively) to be used for bending and shear
- Curve 3 approximately represents the average of the general stress-strain relationship (SN EN 1992-1-2, 3.2.3) from $\varepsilon_s = 0\%$ to $\varepsilon_s = 2\%$ (yielding), to be used for bending and axial load

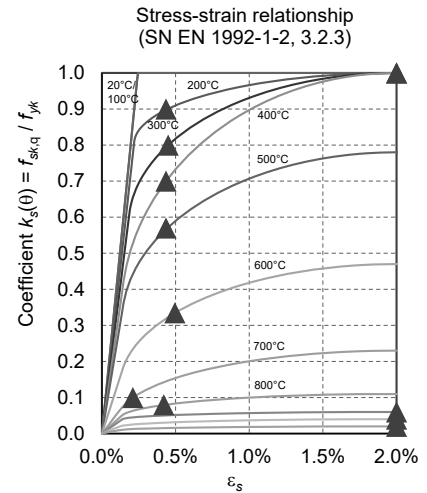
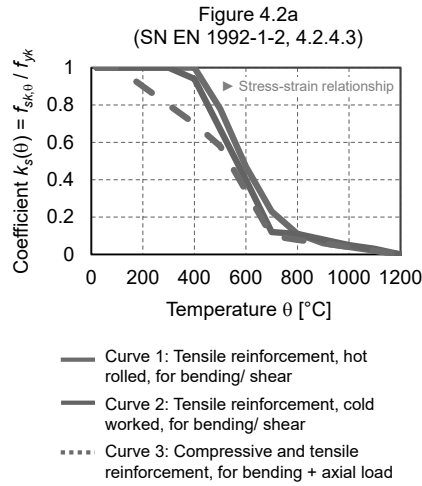

In cases where the tension zone is exposed to fire, the yield strength in fire design, $f_{sd,fi}$, may be assumed in any case for the verification of bending (without carrying out a strain check), because:

- The steel strength of the extreme reinforcement layers (with the largest effective depth of the cross-section) will be at least $0.9 f_{yk}$ (the curve between the proportional limit and the yield strain is very flat from around $\varepsilon_s = 1\%$).
- Reinforcement layers close to the neutral axis may have lower strains than 1%, but will contribute considerably less to the bending resistance.

Design and structural analysis

Verification with simplified design methods according to SN EN 1992-1-2 (cross-sectional resistance)

2. Mechanical analysis for *beams/ slabs*

Example (from Lennon et al., 2007)

Cross section dimensions: $h = 600$ mm, $b = 250$ mm

Span: $l = 7500$ mm

Concrete cover (for stirrups): $c_{nom} = 20$ mm

Concrete strength: $f_{ck} = 30$ MPa

Steel strength: $f_{yk} = 500$ MPa

Standard fire curve

$$T_{sd} = 2 \cdot A_{s,b} \cdot f_{sd} = 699 \text{ kN}, x = \frac{T_{sd}}{b \cdot f_{cd}} = 165 \text{ mm}, c = 0.8 \cdot x = 132 \text{ mm}$$

$$z = h - 48 \text{ mm} - \frac{c}{2} = 486 \text{ mm}, M_{Rd} = T_{sd} \cdot z = 340 \text{ kNm}$$

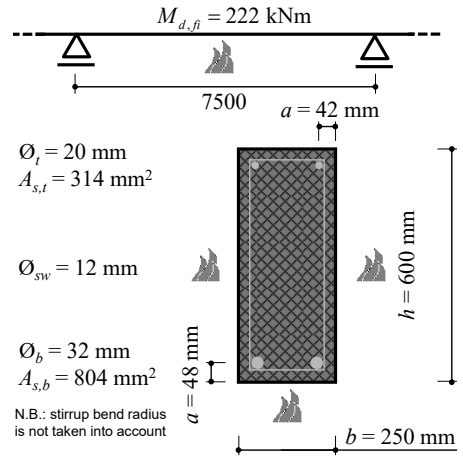

Design and structural analysis

Verification with simplified design methods according to SN EN 1992-1-2 (cross-sectional resistance)

2. Mechanical analysis for *beams/ slabs*

Example for R90

– Zone Method

$$a_z = 27.5 \text{ mm}$$

$$k_s(\theta) = 0.61$$

$$b_{fi} = 250 \text{ mm} - 2 \cdot a_z = 195 \text{ mm}$$

$$N_{sd,t,fi} = A_{st} \cdot k_s(\theta) \cdot f_{sk} = 494 \text{ kN}$$

$$x_{fi} = \frac{N_{sd,t,fi}}{0.8 \cdot b_{fi} \cdot k_c(\theta) f_{ck}} = 107 \text{ mm}, x_{e,fi} = 0.8 \cdot x_{fi} = 86 \text{ mm}$$

$$z_{fi} = h - a - \frac{x_{e,fi}}{2} = 509 \text{ mm}$$

$$M_{Rd,fi} = N_{sd,t,fi} \cdot z_{fi} = 252 \text{ kNm (FE: } M_{Rd,fi} = 247 \text{ kNm)}$$

$$\varepsilon_{s,t} = \varepsilon_{cu} \cdot \frac{h - a - x_{fi}}{x_{fi}} = 1.5\% < 2\%$$

– Methodology from Annex E

$$k_s(\theta) = 0.61$$

$$N_{sd,t,fi} = A_{st} \cdot k_s(\theta) \cdot f_{sk} = 494 \text{ kN}$$

$$x_{fi} = \frac{N_{sd,t,fi}}{0.8 \cdot b \cdot f_{ck}} = 82 \text{ mm}, x_{e,fi} = 0.8 \cdot x_{fi} = 66 \text{ mm}$$

$$z_{fi} = h - a - \frac{x_{e,fi}}{2} = 519 \text{ mm}$$

$$M_{Rd,fi} = N_{sd,t,fi} \cdot z_{fi} = 257 \text{ kNm (FE: } M_{Rd,fi} = 247 \text{ kNm)}$$

$$\varepsilon_{s,t} = \varepsilon_{cu} \cdot \frac{h - a - x_{fi}}{x_{fi}} = 1.99\% < 2\%$$

Design and structural analysis

Verification with simplified design methods according to prEN 1992-1-2 (cross-sectional resistance)

2. Mechanical analysis for columns

1. Determination of the width of the rim zone a_z :

$$a_z = \begin{cases} 0.011 \cdot \sqrt{1 + \frac{R_{fi} - 27}{27}} \cdot \sqrt{\frac{w}{0.0125}} & \text{for } 0.075 \leq w < 0.20 \\ 0.011 \cdot \sqrt{1 + 4 \frac{R_{fi} - 27}{27}} & \text{for } w \geq 0.20 \end{cases}$$

where R_{fi} [min] is the design resistance for the load-bearing criterion in fire situations and w [m] is a reduced cross-section depending on the fire exposure.

2. Determination of a reduced width and height of the cross-section by excluding the rim zone a_z

3. Determination of the reduction of the concrete compression strength $k_c(\theta)$ (Section 4 of SN EN 1992-1-2) based on the temperature in the centre of the cross-section (θ_M).

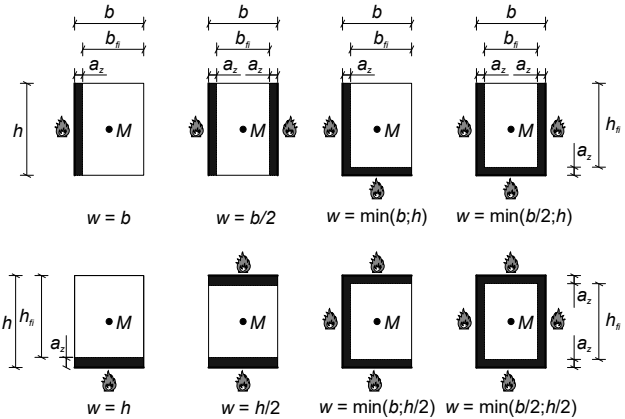

Under fire conditions, the strength and stiffness reduction of the outer layers of the member due to high temperatures, combined with the reduction of the elasticity modulus at the inner layers, results in a decrease of the stiffness of structural members under fire conditions. Because of this, second order effects can be significant for columns in the fire situation although at ambient temperature conditions their effect is negligible.

Design and structural analysis

Verification with simplified design methods according to prEN 1992-1-2 (cross-sectional resistance)

2. Mechanical analysis for *columns*

...

5. Determination of the ultimate load-bearing capacity and verification of the fire design:

- compression zone for $0 \leq x_{fi} < 3(d_{fi} + a_{fi})$

$$\varepsilon_{c0} \leq \varepsilon_{c1,0} \text{ for } x_{fi} < (d_{fi} + a_{fi}),$$

$$\varepsilon_{c0} = \varepsilon_{c1,0} \text{ for } (d_{fi} + a_{fi}) \leq x_{fi} < 3(d_{fi} + a_{fi}),$$

$$x_{c,fi} = \min \left(0.6 \frac{\varepsilon_{c0}}{\varepsilon_{c1,0}}, 0.75 - 0.15 \frac{x_{fi}}{d_{fi} + a_{fi}} \right) x_{fi},$$

$$y_{fi} = \max \left(0.65, 0.55 + 0.10 \frac{x_{fi}}{d_{fi} + a_{fi}} \right) x_{fi},$$

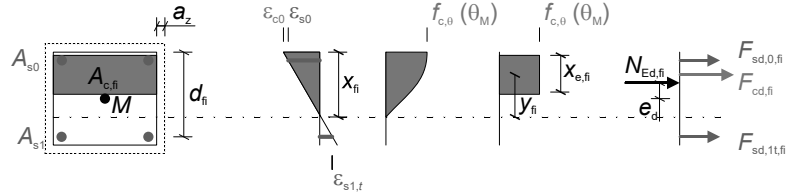

where:

- ε_{c0} is the maximum compressive strain in the concrete at the edge of the cross-section
- $d_{fi} = d - a_z$ is the reduced depth of a cross-section
- $a_{fi} = a - a_z$ is the reduced axis distance of the reinforcement.

Design and structural analysis

Verification with simplified design methods according to prEN 1992-1-2 (cross-sectional resistance)

2. Mechanical analysis for *columns*

...

5. Determination of the ultimate load-bearing capacity and verification of the fire design:

- resisting reinforcement forces

$$F_{sd,0,fi} = \max \left\{ E_{s,fi} A_{s0} \left(\varepsilon_{s0} - 1.35 \cdot 10^{-5} (\theta_{sc} - 20^\circ\text{C}) (1 - a_{fi}/d_{fi}) \right); -A_{s0} k_{s, \text{Curve 3}}(\theta) f_{yk} \right\}$$

$$F_{sd,t,fi} = \min \left\{ E_{s,fi} A_{s1} \varepsilon_{s1,t}; A_{s1} k_{s, \text{Curve 3}}(\theta) f_{yk} \right\} \text{ if } x_{fi} < d_{fi}$$

$$F_{sd,c,fi} = \max \left\{ E_{s,fi} A_{s1} \varepsilon_{s1,c}; -A_{s1} k_{s, \text{Curve 3}}(\theta) f_{yk} \right\} \text{ if } x_{fi} > d_{fi}$$

where:

- ε_{s0} and $\varepsilon_{s1,c}$ are the compression strains in the relevant reinforcing layers,
- $\varepsilon_{s1,t}$ is the tension strain in the relevant reinforcing layer,
- A_{s0} and A_{s1} correspond to the steel cross section in the relevant reinforcing layer,
- $\theta_{sc} = \frac{\sum_{i=1}^{i=n_{sc}} \theta_{sc,i}}{n_{sc}}$ ($^\circ\text{C}$) represents the average temperature of all effective reinforcing bars in the compression zone with n_{sc} being the number of effective reinforcing bars in the compression zone.

Design and structural analysis

Verification with simplified design methods according to prEN 1992-1-2 (cross-sectional resistance)

2. Mechanical analysis for *columns*

...

5. Determination of the ultimate load-bearing capacity and verification of the fire design:

- design moment

$$M_{d,fi} = -N_{d,fi} \cdot e_d,$$

where:

$$e_d = e_{0d} + e_{1d} + e_{2d} + e_{thermal}$$

e_{0d} , e_{1d} , and e_{2d} are defined as given in SIA 262. $e_{thermal}$ is defined as:

$$e_{thermal} = \frac{l_{0,fi}^2}{8} \cdot \max \left\{ \frac{1.2 \cdot 10^{-5} \cdot \max(\theta_T - 20^\circ\text{C}; 180^\circ\text{C})}{d_{fi} + a_{fi} + a_z - y_T}; \frac{1.35 \cdot 10^{-5} (\theta_{st} - 20^\circ\text{C})}{d_{fi}} \right\}$$

where:

- θ_T (°C) is the concrete temperature in the reference point T. The reference point T is located at $y_T = \min(\bar{\theta}_i) 125(d+a)$, 50 mm from the edge of the tension side of the cross-section.
- $\theta_{st} = \frac{\sum_{i=1}^{n_{st}} \theta_{st,i}}{n_{st}}$ (°C) represents the average temperature of all effective reinforcing bars in the tension zone with n_{st} being the number of effective reinforcing bars in the tension zone.

For approximate solutions, the maximum curvature may be estimated as

$$\chi_d \approx \frac{2k_{s, \text{Curve 3}}(\theta) f_{yk}}{E_{s, fi} (d_{fi} - d'_{fi})}$$

Design and structural analysis

Verification with simplified design methods according to prEN 1992-1-2 (cross-sectional resistance)

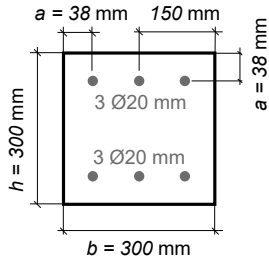

Column properties	
e_1	5 mm
l_{cr}	3.76 m
$l_{cr,ff}$	3.76 m
λ_{ff}	43.4
Material properties	
f_{sk}	452 MPa
f_c	42.3 MPa
E_s	200 GPa

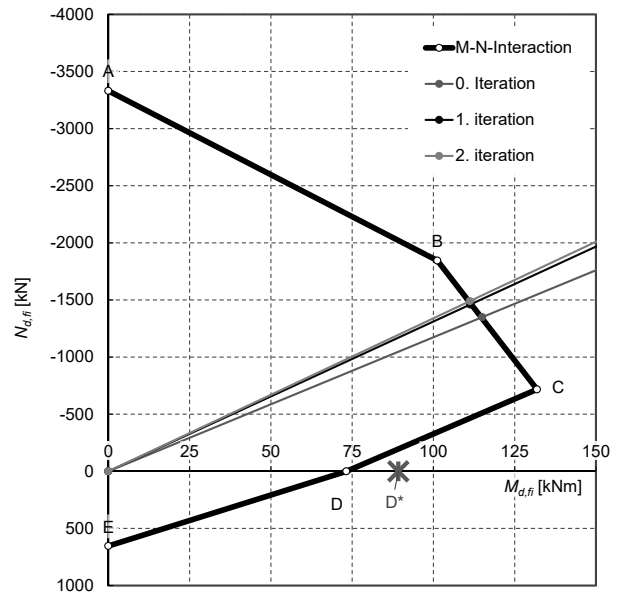

Design and structural analysis

Verification with simplified design methods according to SN EN 1992-1-2 (cross-sectional resistance)

2. Mechanical analysis

1. Determination of the width of the rim zone a_z
2. Determination of a reduced width and height of the cross-section by excluding the rim zone a_z
3. Determination of the reduction of the concrete compression strength (use Figure B.5a) with only one zone $\rightarrow \theta_M =$ Temperature in the centre of the cross-section

Shear without / with little shear reinforcement

- Verifications may be conducted by using the first three steps of the simplified design method introduced above for bending.
- The design shear strength should be reduced by the factor $k_{ct} = f_{ct,\theta} / f_{ct}$
- For members with no or little shear reinforcement (e.g. Hollow-Core-Slabs), thermal strains have a negative influence on the resistance for shear loads.

Design and structural analysis

Verification with simplified design methods according to SN EN 1992-1-2 (cross-sectional resistance)

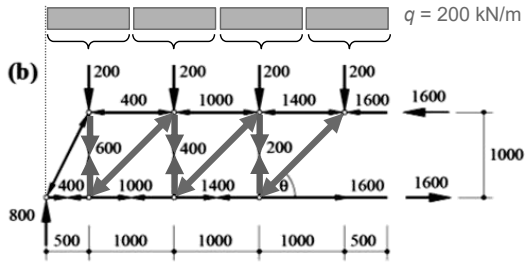
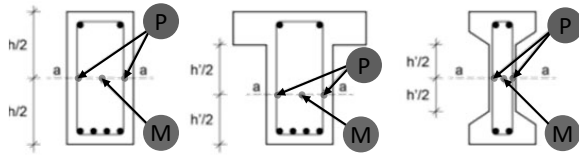

[Marti et al., 1999]

Shear and torsion with shear reinforcement

- Verifications may be conducted by using the simplified design method introduced above for bending.
- The concrete compression strength is reduced relying on the temperature at the reference point M with $f_{c,\theta} = f_{c,\theta}(M)$.
- The tensile strength of the stirrups is reduced relying on the temperature at the reference point P with $f_{s,\theta} = f_{s,\theta}(P)$.
- Increased shear loads to be considered (to account for load redistributions) if stirrups with more than two legs are used
- The same procedure may be applied to verify torsion.

Design and structural analysis

Verification by advanced design methods

Step 1: Thermal analysis

Time-dependent evaluation of temperature field within cross-sections with thermal material properties

Step 2: Mechanical analysis

Time-dependent evaluation of internal and external actions (restraint!)

Step 3: Verifications

Verification of load-bearing capacity

$$E_{fi,d,t} \leq R_{fi,d,t}$$

Verification of fire resistance time

$$t_{fi,d} \leq t_{fi,req}$$

Verification of critical temperatures

$$\theta_d \leq \theta_{cr,d}$$

Requirement:

no significant spalling

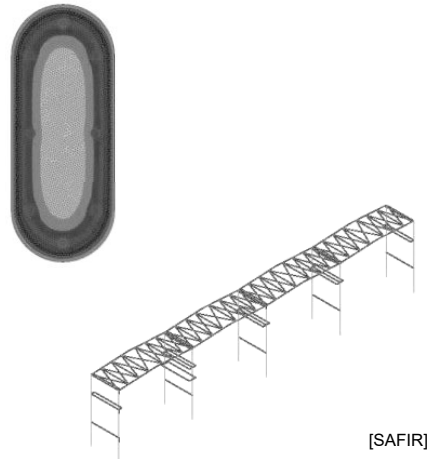

- Simulation of the behaviour of members, part of a structure or entire structures over time as a function of thermal and mechanical effects.
- When using advanced design methods according to SN EN 1992-1-2, explosive spalling should be avoided.
- Dimensions (especially the axis distance) are of utmost importance in fire design. No tolerances are defined for the axis distance in the tabulated design data of SN EN 1992-1-2, however, the generally used 10 mm is too much if is systematical. When computing performance-based design with advanced design methods, tolerances should be added to the axis distance (concrete cover is a nominal value!).

Design and structural analysis

Verification by advanced design methods

- The fire load usually is considerably lower than in tests/ covered by the code with the Standard fire curve.
- Calibration of the used material relationships is unavoidable if part of a structure or entire structures are modelled (especially if internal actions are evaluated for statically indeterminate systems).
- Model uncertainty should be considered, safety concept (partial factors or global safety factor) should be adopted to the design problem.

Conclusion:

A global structural analysis with advanced design methods is highly demanding to designing experts

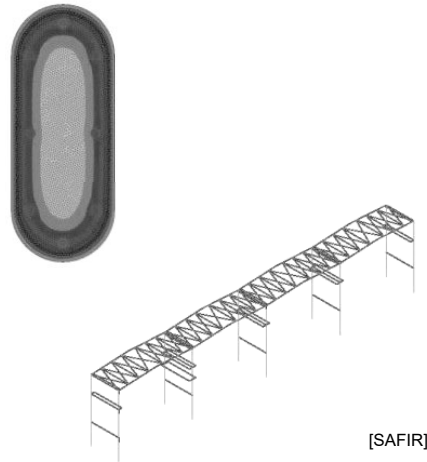

- With user-friendly FE programs, fire analyses are carried out rather quickly. However, it is strongly recommended to critically question the results and verify them for plausibility with comparison calculations.
- The calculation programs used should be validated, e.g. according to DIN EN 1991-1-2/NA:2010-12 Annex CC.

Design and structural analysis

Verification by experiments

- Fire tests under standard fire exposure by recognised test institutes.

Example: Tests 1:1 under load at the Bundesanstalt für Materialforschung und -prüfung in Berlin

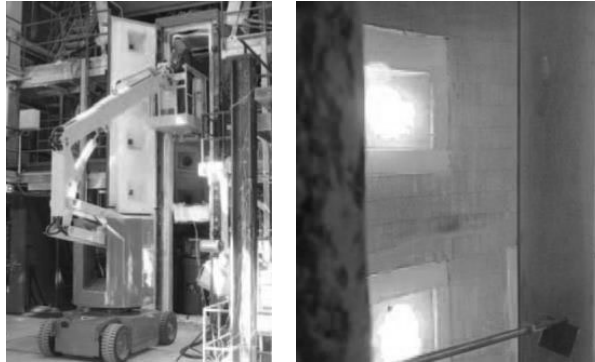

[F.J. Aschwanden AG 2014]

Design and structural analysis

Evaluation of design methods

Minimum size of reinforcement (mm)	Minimum member dimensions (mm)					
	Columns	Walls	Slabs	Room/room slabs	Flat	Beam depth
20	150	120	60	150	200	150
20	200	140	80	150	200	150
30	240	170	100	150	200	150
30	280	220	120	150	200	150
40	360	300	150	200	200	400

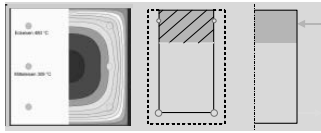

- Level 1: Verification with tabulated design data
 - Covers most design scenarios
 - Quick and easy application
 - Not always more conservative than other design methods
- Level 2: Verification with simplified design methods
 - Deliver structural understanding
 - Easy application
 - (Almost) always conservative than advanced design methods
- Level 3: Verification by the advanced design methods
 - “black box”: numerous thermal and mechanical input parameters ▶
 - useful for fire curves different to Standard fire curve
 - double check with table or simplified design method
- Level 4: Verification by experiments
 - Expensive (only reasonable for example columns)

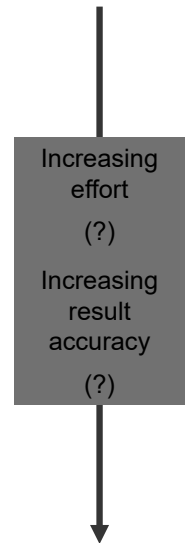

Learning objectives

Fire behaviour of concrete structures

What criteria should be used by engineering consideration when designing concrete structures?

Judge when closer fire engineering consideration is necessary for reinforced concrete



Material behaviour under fire conditions

Describe the material behaviour under fire conditions

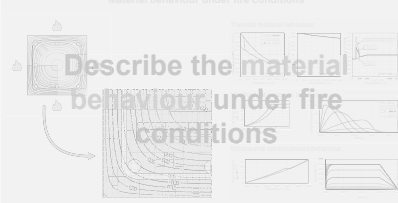

Structural behaviour under fire conditions

Describe the structural behaviour under fire conditions



Design and structural analysis

Select the most suitable verification method(s) for the fire design



Design and structural analysis

Apply simplified design methods and understand their relation to design methods at ambient temperature



Understand the need for design verifications related to explosive spalling and use the appropriate measure to deal with it

Explosive spalling of concrete

Concretes or members at risk of explosive spalling:

- High strength and ultra high strength concrete
- Very dense concrete (e.g. self compacting concrete)
- Highly stressed members (columns, supports)

After explosive spalling of the concrete cover, the reinforcement is no longer protected from the effects of temperature. Hence, fire safety must be demonstrated for concretes at risk, taking into account explosive spalling, or preventive measures must be taken.

NB: The great attention that explosive spalling in the event of fire has received in the last 10 years in Switzerland was triggered by extensive damages in tunnel fire events (very extreme fire exposure) and the extremely explosive behaviour of loaded high strength concrete (compressive strength classes \gg C50/60) in fire tests.



The VKF, whose fire protection regulations are binding throughout Switzerland, has required fire resistance certificates for high-strength columns since December 2012.

In the period from January 2013 to the end of 2015, most Swiss manufacturers of high-strength columns carried out extensive 1:1 fire tests after "spalling-proof" high-strength concretes had been developed for this purpose. Today, almost all Swiss manufacturers of columns and prestressed ribbed slabs have products with VKF approval.

At the same time, various working groups were set up at European level and within SIA Standards Commission (NK) 262 to deal with explosive fire spalling (with the active participation of the IBK). Working groups of the NK SIA 262 have made an effort for providing clear and safe design rules (SIA 262-C1:2017).

Explosive spalling of concrete

What members require closer fire engineering consideration when designing concrete structures?

Slender columns/ highly loaded walls with small member dimensions (HPC/ UHPC)

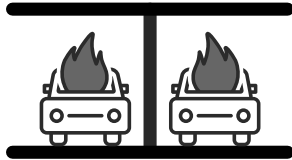

Statically indeterminate slabs without (punching) shear reinforcement

Members with slender webs (especially when using HPC or UHPC)



Hollow core slabs

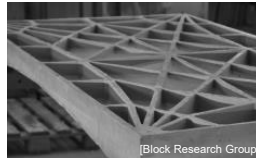

Ribbed slabs

Members with intense fire exposure (tunnels/ tunnel segments, fire ratings >R90)



Explosive spalling of concrete

Approach to explain the phenomenon:

- Temperature increase → Vapour pressure in concrete (water vapour tries to escape) and thermal stresses (restrained expansion, note: reinforced concrete ≠ homogeneous).
- Thermal stress is superimposed to mechanical stress.
- Possible criterion for plausibility:
Spalling if the resulting stress exceed the tensile strength of concrete (reduced by temperature increase).

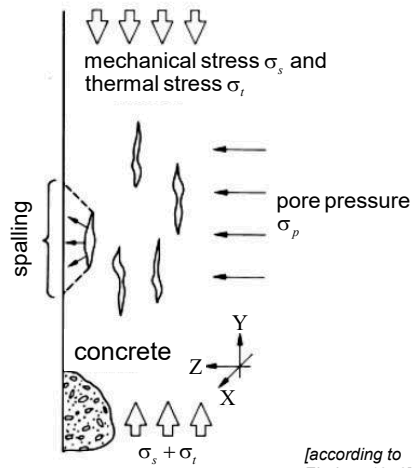

Explosive spalling of concrete

Influencing parameters include:

- Effect of temperature (heating rate)
- Type of aggregates (lightweight, recycled)
- Mechanical stress
- Cracks
- Concrete composition (→ concrete properties)
- Moisture content
- Reinforcement density and arrangement
- ...

Current state of knowledge:

Despite progress in research, it is still not possible today to specify generally applicable, reliable quantitative rules for the prediction or the prevention of explosive spalling.

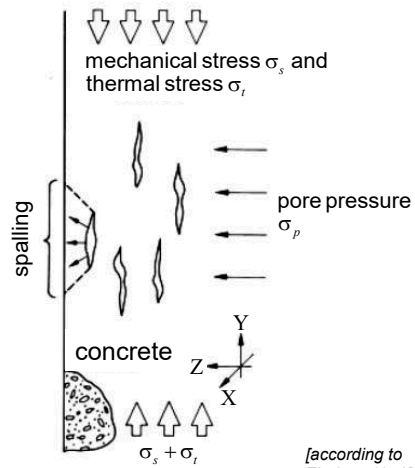

[according to Zhukov, 1976]

Explosive spalling of concrete

Standard provisions identifying the risk of explosive spalling for Standard fire curve

- SN EN 1992-1-2 → purely material-based approach:
 - Moisture content $k < 3\%$ for $\leq C50/60$
 - $\geq C55/60$ to $\leq C80/95$: Silica fume content $< 6\%$.
 - Exposure classes X0 and XC1 for $2.5\% \leq k \leq 3\%$
 - Verification with tables (for $\leq C50/60$)
- SIA 262 → implied risk-based approach (explanation see next slide):

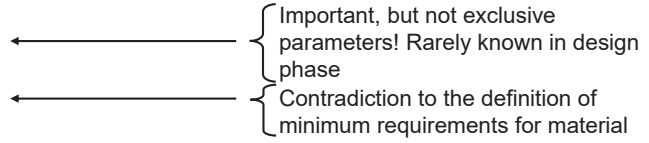

	$\leq R 30$	R 60	R 90	$> R 90$
$\leq C25/30$	No verification	$f_{cm,28} = 45 \text{ MPa}$ ▼	No verification	
C30/37			Verification required for self-compacting concrete (SCC), Definition of SCC via flow classes Exception: redundant / ductile members and robust structures	
C35/45				
C40/50				
C45/55				
C50/60		Verification required (all consistency classes) Exception: redundant / ductile members and robust structures		
$> C50/60$	Exception: redundant / ductile members and robust structures			

- Design provisions in SN EN 1992-1-2 and SIA 262 concerning explosive spalling are only valid for the Standard fire curve

The current provisions of SN EN 1992-1-2 are insufficient and mostly unusable in the design phase (moisture content and content of silica fume) for the identification of an "explosive spalling issue".

Explosive spalling of concrete

Risk-based approach dealing with uncertainties related to material behaviour

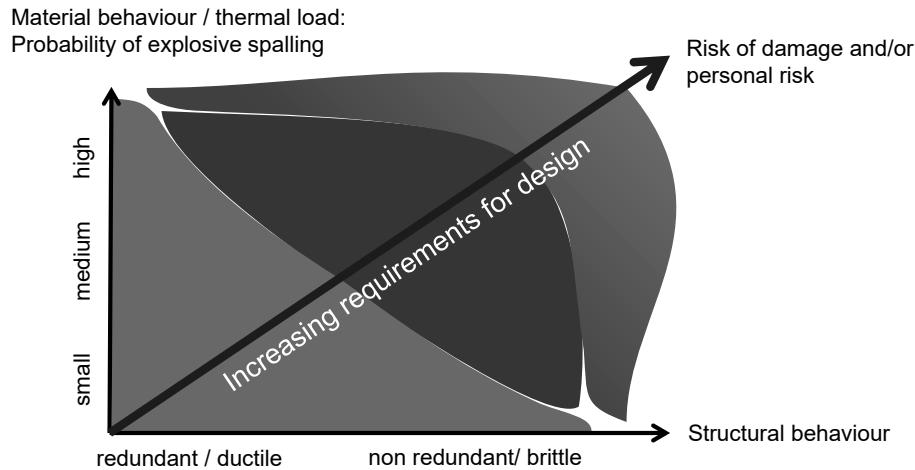

Fire design is associated with higher uncertainties than the design for ambient temperature conditions. Typically, the fire load in reinforced concrete buildings underlies a considerable uncertainty as it only depends on the amount of available combustible material within fire compartments of concern.

With the risk-based approach, uncertainties with respect to the material behaviour or thermal load are weighted by taking the structural behaviour into account. Robust structures are less susceptible to disproportionate collapse (the assessment of the structural behaviour lies within the responsibility of the

Method	Reduces	Issues to address
a. Event control (EC)	Probability of occurrence and/or the intensity of an accidental event	<ul style="list-style-type: none"> Monitoring, quality control, correction and prevention
b. Specific load resistance (SLR)	Probability of local, i.e. direct, damage due to an accidental event	<ul style="list-style-type: none"> Strength and stiffness Benefits of strain hardening Ductility versus brittle failure Post-buckling resistance Mechanical devices
d. Alternative load path method (ALP), including provision of ties	Probability of further, indirect, damage in the case of local damage	<ul style="list-style-type: none"> Multiple load path or redundancy Progressive failure versus the zipper stopper Second line of defence Capacity design and the fuse element Sacrificial and protective devices Testing Strength and stiffness Continuity and ductility
d. Reduction of consequences	Consequences of follow up, i.e. indirect, damage such as progressive collapse	<ul style="list-style-type: none"> Segmentation Warnings, active intervention and rescue Redundancy of facilities

design engineer).

According to SIA 260:2013, robustness is defined as "the ability of a structure and its components to limit damage or failure to dimensions that are in reasonable proportion to the cause". According to COST Action TU0601 (2011), the possible design methods for this purpose may be classified as follows:

Explosive spalling of concrete

Identification of an “explosive spalling issue” according to prEN 1992-1-2:2019

	Tabulated design data	Simplified design methods	Advanced design methods
≤C 60/75	No verification unless: • Silica fume content ≥ 6% • Exceptions below apply	No verification unless: • Slender columns highly loaded (to be defined) <ul style="list-style-type: none"> • Slender webs • Silica fume content ≥ 6% • Exceptions below apply	
C 70/85	Verification required		
C 80/95			
C 90/105			
C 100/115			

Verification required in any case:

- lightweight aggregate concrete
- buildings in a water saturated environment
- insulating permanent formwork which prevents concrete from drying

Tabulated data have been developed based on fire tests or on calculations calibrated against full scale fire resistance tests, including tests where spalling occurred. However, it is not documented, how the results from experiments where explosive spalling occurred were considered. It is recommended not to treat tabulated design data differently to simplified and advanced design methods in terms of explosive spalling.

Requirements in prEN 1992-1-2:2018 are defined according to concrete strength classes. If the mean strength of the concrete used in construction (f_{cm} at $t_{ref} = 28$ days) exceeds the mean strength (f_{cm}) of the next higher resistance class than the considered one, the susceptibility of the concrete to spalling is higher.

Explosive spalling of concrete

Measures: PP fibres

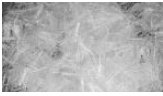

[www.expressbeton.at 2016]

Tests on specimens with PP fibres



UHPC
4 kg/m³ PP fibres
 $d = 32 \mu\text{m}$
 $l = 6 \text{ mm}$



UHPC
2 kg/m³ PP fibres
 $d = 18 \mu\text{m}$
 $l = 6 \text{ mm}$

[Klingsch et al., 2013]

During fire, the permeability of concrete containing a sufficient amount of PP fibres is increased by the expansion and melting of fibres (breaking free - by microcracking – and melting provide “channels” to relieve the pressure). However, the specifications in the currently valid standards (SIA and SN EN), i.e. the addition of 2 kg/m³ PP fibres, are not sufficient, as length and diameter also have a major influence on explosive spalling behaviour. Furthermore, the polypropylene (PP) fibres have an influence on the workability of the concrete. Hence, both the PP fibres themselves and the concrete mix containing them should, therefore, be examined by testing.

Explosive spalling of concrete

Measures: PP fibres

Tests on UHPC concrete slabs with PP fibres: No spalling after 120 min exposure to Standard fire curve

UHPC
2 kg/m³ PP-Fasern
 $d = 18 \mu\text{m}$
 $l = 6 \text{ mm}$

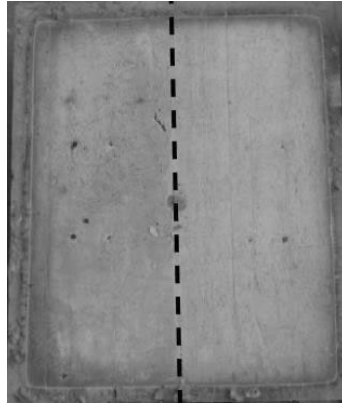

UHPC
3 kg/m³ PP-Fasern
 $d = 18 \mu\text{m}$
 $l = 6 \text{ mm}$

[Klingsch et al., 2013]

During fire, the permeability of concrete containing a sufficient amount of PP fibres is increased by the expansion and melting of fibres (breaking free - by microcracking – and melting provide “channels” to relieve the pressure). However, the specifications in the currently valid standards (SIA and SN EN), i.e. the addition of 2 kg/m³ PP fibres, are not sufficient, as length and diameter also have a major influence on explosive spalling behaviour. Furthermore, the polypropylene (PP) fibres have an influence on the workability of the concrete. Hence, both the PP fibres themselves and the concrete mix containing them should, therefore, be examined by testing.

Explosive spalling of concrete

Measures: Fire protection systems

Tests on HPC concrete slabs with coating of thickness d_p : 120 min exposure to Standard fire curve



Continuous spalling after
17 min of fire exposure
 $d_p = 0$ mm



Explosive spalling after
119 min of fire exposure
 $d_p = 10$ mm



No spalling

$d_p = 20$ mm
[Klingsch et al., 2013]

Fire protective systems delay the thermal load on a reinforced concrete member. However, spalling cannot be excluded if the fire exposure lasts longer than expected. Fire protective systems include sprayed materials, reactive coatings, cladding protection systems and multi-layer or composite fire protection materials. The properties and performance of the material for fire protective systems should be assessed using appropriate (European) test standards. If used as a measure against spalling of at-risk concretes, reactive coatings shall be explicitly tested against explosive spalling and applied to building members by specialists. Tests show that overly strong fire protective coatings may peel while heated.

Generally, fire protective systems may be used to retrofit existing structures but should be avoided in the design of new structures (generally expensive solution).

Explosive spalling of concrete

Measures against explosive spalling of concretes or members at risk

- Use of concrete of strength class $< C50/60$ (crane/pumped concrete) or $f_{cm,28} \leq 45$ MPa (self-compacting concrete)
- Design of redundant / ductile members and robust structures
prEN 1992-1-2:2019: Influence on performance (R and/or EI) of severe spalling may be taken into account considering the loss of strength of member(s) either at member or at structure level by a reduced effective cross section omitting a spalled layer of concrete based on experimental evidence.
- Use of members with valid *VKF-Zertifikat* (columns and prestressed ribbed slabs)
- Verification with fire tests to obtain *VKF-Zertifikat*:
 - «direkter Anwendungsbereich»: each test only applies to the member as tested
 - «erweiterter Anwendungsbereich»: several tests, further analyses carried out by experts
→ useful for precast elements with large quantities and varying configurationsFor other fire curves than the Standard fire curve, fire tests are necessary.
- Use of concrete mixes with PP fibres/ use of protective layers.
The effectiveness of PP fibres in the corresponding concrete mix and of protective layers must be demonstrated by tests (e.g. defining the exact geometry of the PP fibres, uniform distribution of the PP fibres indispensable).

- When using high strength precast elements, the requirement of a valid *VKF-Zertifikat* should be specified in the submission by the project designer and verified prior to execution.
- A reduction of partial safety factors is not permissible for precast elements, although this would in principle be in line with the Construction Products Regulation (CPR) for precast elements. However, the structural standards take precedence over these in questions of structural safety and durability (hierarchy of standards). The Swiss Annex to SN EN 1992-1-2 does not allow for a reduction of the partial safety factors for precast elements.

Assessment of existing structures

- Even though the standards SIA 262 and SN EN 1992-1-2 are intended for the design of new structures, they are used for the assessment of existing structures (no standards are available for the assessment of existing structures exposed to fire)
- Thermal properties and reduction factors for mechanical properties given in SN EN 1992-1-2 may be used.
- Tabulated design data as well as simplified and advanced design methods given in SIA 262 and SN EN 1992-1-2 may be used provided the cross-section geometry is retained throughout the fire (no explosive spalling).
- No systematic studies on the susceptibility of existing concrete (with increased concrete strength (*) and reduced moisture content) to explosive spalling are available. Tests on few samples of existing structures indicate that concretes built before 1995 tend to have a low probability of explosive spalling.
- An increased susceptibility of existing concrete to spalling may be approached by a systematic structural analysis defining alternative load paths.

(*) relevant since old concrete, particularly if produced several decades ago with almost 100% clinker cement (CEM I), typically has a much higher compressive strength today than at the time of construction, and, therefore, violates the spalling susceptibility criteria of current guidelines solely depending on the compressive strength.

Assessment of existing structures

Typical procedure:

1. Study of plans / analysis of structure
2. Investigation on site
 - Determination / verification of minimum member dimensions
 - Determination / verification of concrete cover / average axis distance per member
 - Estimation of actual concrete strength, e.g. by Schmidt hammer

Possibly more detailed investigation:

- Concrete strength from samples (useful also to calibrate Schmidt hammer results)
 - Concrete permeability: air-permeability (see Figure) or oxygen permeability
 - Concrete moisture content
3. Determination of fire resistance time
 - Check of cross-sectional dimensions by tabulated design data or analysis with simplified / advanced design methods

Possibly more detailed investigation:

- Check of susceptibility to explosive spalling by testing (representative conditions)



[TFB AG]

- In SN EN 1992-1-2, the axis distance is defined as nominal value, however without any specifications on acceptable tolerances. Generally, the fire resistance is rather sensitive to changes of the axis distance, which is the reason why this issue is debated among fire experts. In Switzerland, the suggestion by Unterbuchberger and Müller (2015) has been adopted (suggestion on measured concrete cover):

$$c_{calc} = \min \begin{cases} \bar{c} \\ c(5\%) + 15 \text{ mm} \\ c(10\%) + 10 \text{ mm} \end{cases}$$

where \bar{c} is the measured average concrete cover per member.

Measured concrete covers at critical positions should not be compensated by measurements in other (less critical) positions.

- Measured permeability values usually lie between 10^{-16} m^2 and 10^{-19} m^2 . Due to these low numbers, a certain range of uncertainty should be considered in the permeability measurements because they are influenced by the presence of aggregates, surface condition (e.g. unevenness), etc. Therefore, several measurements should be taken.

Summary



Minimum member dimensions [mm]	Dimensions [mm]			Beam web width
Slabs	Mushroom slabs	Flat slabs	Slabs	
60	150	50	150	100
80	150	200	150	150
100	150	200	200	200
120	150	200	200	200
150	200	200	200	400

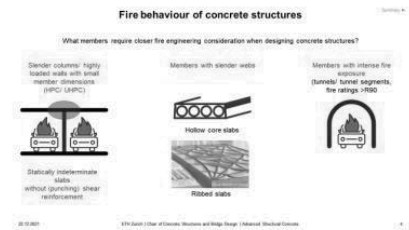

In principle, concrete offers good protection against high temperatures caused by fire.

The fire resistance of reinforced concrete structures can in most cases be ensured by conceptual decisions and quick verifications of minimum dimensions using tabulated design data.

Some members require closer fire engineering consideration when designing concrete structures

Increased temperatures induced by fire action cause:

- Heating of reinforced concrete cross-section depending on thermal material properties
- Degradation of mechanical material properties
- Propensity to explosive spalling
- Altered internal actions and reactions (in statically indeterminate structural systems)

Learning objectives - Summary

Fire behaviour of concrete structures

What members require closer fire engineering consideration when designing concrete structures?

Judge when closer fire engineering consideration is necessary for reinforced concrete

Material behaviour under fire conditions

Describe the material behaviour under fire conditions

Structural behaviour under fire conditions

Describe the structural behaviour under fire conditions

Design and structural analysis

Select the most suitable verification method(s) for the fire design

Design and structural analysis

Apply simplified design methods and understand their relation to design methods at ambient temperature

Explosive spalling of concrete

Understand the need for design verifications related to explosive spalling and use the appropriate measure to deal with it