

# 5 Steel Fibre Reinforced Concrete (SFRC)

## Fundamentals

# Steel Fibre Reinforced Concrete – Fundamentals

## Content

- Relevance of SFRC and current applications
- Mechanical behaviour of a single fibre in cement matrix
  - Fibre types and properties
  - Bond
  - Fibre activation and pull-out
  - Fibre stress – crack opening relationship
- Fibre content and orientation in 2D and 3D
- Mechanical behaviour of SFRC
  - Tension
  - Bending
  - Compression
  - Shear
  - Hybrid reinforcement (SFRC and conventional reinforcing bars)
- Ultra High Performance Fibre Reinforced Concrete (UHPFRC)

# Relevance of SFRC and current applications

## Historical background

- First trials to replace conventional reinforcement with fibres date back to the 1960s
- Further research led to a wider application in practice, e.g. shotcrete in tunnel linings
- Other materials (PVA, glass fibres) lead to similar behaviour, but are not treated here
  
- The addition of fibres enhances the structural performance of plain concrete (much higher fracture energy, not “ductility”!)
- Fibres reduce the crack spacing and crack width, thereby improving serviceability and durability
- Currently used SFRC mixes exhibit a softening behaviour in tension and cannot fully replace conventional reinforcement
- Hybrid reinforcement (fibres and conventional reinforcing bars) can be used, but may affect ductility
  
- Several causes are preventing a more widespread use of SFRC:
  - ... Lack of standardised design procedures and material test procedures
  - ... High fibre contents (e.g. 1.5% = 120 kg/m<sup>3</sup>) as required for structural applications (and used in many experiments) are causing severe problems in terms of mixing and workability of concrete mix
  - ... With common fibre contents (up to 0.5% = 40 kg/m<sup>3</sup>), the tensile strength of concrete cannot be matched at cracking → softening behaviour

Steel fibre reinforced concrete (SFRC) has been investigated in academia for more than 50 years. The addition of fibres aims at reducing the brittleness of plain concrete by transmitting stresses across cracks. However, its use in construction practice is limited to few, typically non-structural applications. The main reason for this limited use is the inherent softening behaviour of SFRC after cracking: The practically feasible steel fibre content is limited by the workability of the concrete mix, and standard fibre contents therefore result in a tensile capacity of the fibres below the cracking load of the concrete (the load immediately drops after cracking in a deformation-controlled experiment). Furthermore, the fibres are typically pulled out of the matrix, resulting in a softening post-cracking behaviour even if the fibre capacity exceeds the tensile strength of the concrete.

The mixed use of fibres with conventional reinforcement (hybrid reinforcement) may have beneficial effects on serviceability and durability by causing finer crack widths at closer spacing. The ratio between fibre and conventional reinforcement content is crucial to guarantee an overall hardening behaviour.

Many current codes lack standardised design procedures for SFRC and hybrid reinforcement, but rather rely on semi-empirical approaches which were fitted to experimental results. These should be carefully handled since they may not be applicable to general problems. In this lecture, some mechanically consistent models for the structural behaviour of purely fibre reinforced and hybrid reinforced concrete structures are presented.

Other fibre materials such as carbon or glass fibres lead essentially to the same mechanical behaviour of the composite material. Polymer fibres are often used for high-strength concrete to prevent explosive spalling under fire conditions.

# Relevance of SFRC and current applications

## Common fields of application

- Industrial floors
- Shotcrete linings
- Foundation slabs
- Hydraulic structures
- Bridge decks
- Explosion-resistant structures
- Façade elements

For general application in engineering practice (structures), it is necessary to include conventional reinforcement in combination with SFRC to ensure structural safety and an adequate crack distribution.

The addition of steel fibres leads to a reduction of crack spacing and therefore, smaller crack widths.

Experimental investigations show that the influence of steel fibres disappears for highly reinforced concrete elements.



[ Source: Guideline for execution of steel fibre reinforced SCC  
Danish Technological Institute – SFRC Consortium, 2013 ]

Steel fibres are added to the concrete while mixing. The maximum amount of fibres is limited by (i) the workability since the fibres significantly increase the stiffness of the concrete in the wet state and (ii) the fibres tend to tangle at high fibre contents, particularly when using relatively long fibres. SFRC in combination with conventional reinforcement mostly finds its application where higher requirements on serviceability and durability have to be met.

# Relevance of SFRC and current applications

## Examples (selection)

Slab on grade



[ Source: concretefibersolutions.com ]

Shotcrete for tunnel lining



[ Source: bekaert.com ]

Thin shell structures  
(with conventional reinforcement)



[ Source: ciudadfcc.com ]

Steel fibres allow reducing conventional reinforcement in dense geometrical conditions. Additionally, they are beneficial for the ductility and the serviceability of the concrete structure.

One of the most common fields of application of SFRC are slabs on grade with high requirements regarding water tightness, abrasion, fatigue etc. Steel fibres may also be added to the conventional reinforcement to guarantee closer crack spacing and finer cracks.

Steel fibre reinforced shotcrete tunnel linings are widely used as a state-of-the-art procedure. The decrease in conventional reinforcement leads to a much faster construction which can be crucial when dealing with instable soil and rock conditions. The limitations on the workability are more strict due to the dimensions of the spraying hose. Furthermore, the loss of fibres by rebound should be considered.

Thin shell structures are normally built as compression-only structures which allow for very low thickness (6 cm concrete shell at a main span of 35 m in "L'Océanografic" by Felix Candela). However, the shell elements still need some bending and shear capacity to resist asymmetric and horizontal loads.

# Mechanical behaviour of a single fibre in cement matrix

## Types of fibres

Hooked ends



Hooked-end fibres are standard in most applications today. Other fibre types, as shown below, are also being used, or were used historically:

Crimped



Stranded (coned end)



Straight



Twisted

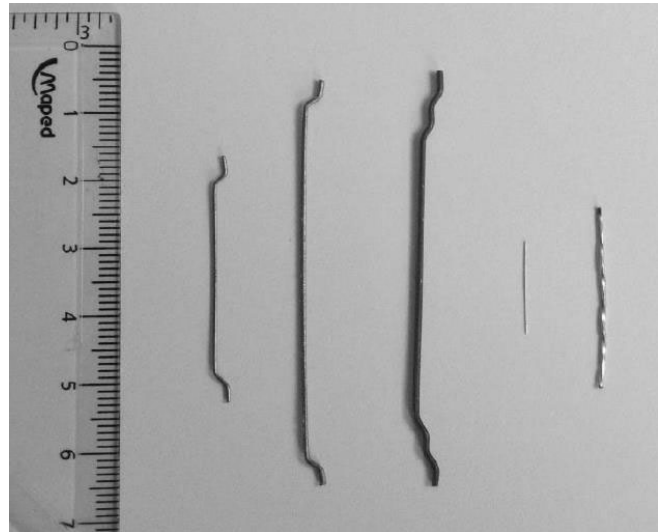

[ Source: Amin, 2015 ]

Various shapes, lengths and thicknesses for steel fibres exist. Hooked-end fibres are standard for most applications since they are also mechanically anchored, whereas straight fibres fully depend on bond stresses along the fibre. Note that independently of the hooked ends, fibres are typically pulled out of the matrix, rather than breaking (i.e. being fully anchored).

The fibre length normally varies between 20 mm (for straight fibres) up to 60 mm (usually hooked-end).

# Mechanical behaviour of single fibre in cement matrix

## Material properties of modern steel fibres

- Steel wire with high tensile strength (usually  $>1'000$  MPa, some  $>2'000$  MPa)
- Typically bare (uncoated steel) or galvanized
- Typical length  $l_f \approx 30 \dots 60$  mm
- Typical slenderness (aspect ratio)  $l_f/d_f \approx 55 \dots 80$
- Usually rather low ductility of the steel (except 5D fibre)

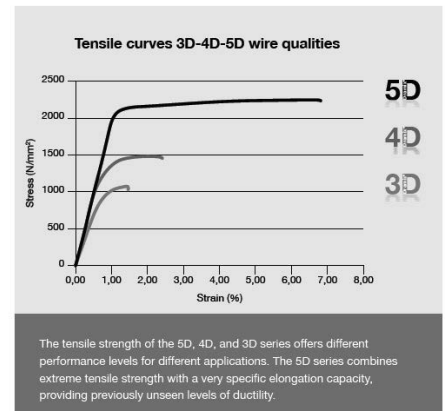
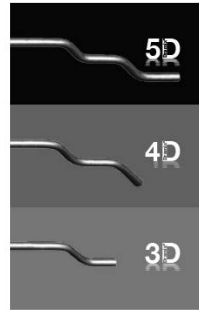

- Fibre designation: slenderness / length:  
«80 / 60»  $\rightarrow l_f/d_f = 80$ ,  $l_f = 60$  mm  
(i.e.  $d_f = 60/80 = 0.75$  mm)

BEKAERT

[ Source: bekaert.com ]

Modern steel fibres are made of high-strength steel with a yield strength above 1000 MPa. Typically, the material ruptures at a rather low ductility. If failure is governed by fibre breakage (rather than the typical pullout), the short length of the fibres combined with their low ductility leads to low ductility of the SFRC since the ultimate strains are already reached at small crack openings.

Dramix® 5D-fibres exhibit a higher strength and much higher ductility than normal fibres. If these fibres are fully anchored in the matrix (which is possible in higher strength concrete due to the special end hook), a high fibre stress and a relatively ductile, strain hardening behaviour may be achieved.

The fibre type refers to the number of different directions that the fibre takes due to the hook at the end.

# Mechanical behaviour of single fibre in cement matrix

## Fibre-matrix failure mechanisms

- Typically, fibres are not fully activated, i.e. they are pulled out of the cement matrix before the fibre breaks.
- Unless long fibres with high ductility (e.g. Dramix 5D) are used, fibre pullout is desirable since fibre fracture would lead to a very low ductility.
- The pull-out of the fibres is softening, i.e. load decreases with increasing crack opening, since the bonded length is reduced in proportion with the crack opening.

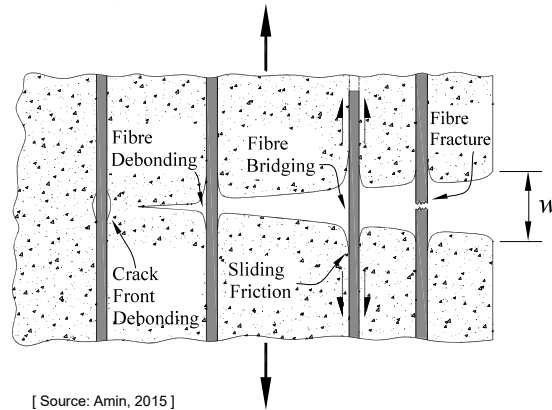

[ Source: Amin, 2015 ]

For normal fibres (except Dramix ® 5D), it is preferable that the fibres are pulled-out out of the matrix rather than being fully activated to their tensile strength. The pull-out of the fibres leads to a much higher ductility since the short fibres would reach their ultimate strains at rather small crack openings if they were fully anchored in the matrix. With progressing pull-out, the bond length of the fibre-matrix-interface continuously decreases, which leads to an overall softening behaviour with increasing crack opening.

Debonding of the fibres would leave them ineffective and is prevented by the use of an adequate cement mix.



# Mechanical behaviour of single fibre in cement matrix

## Bond-slip relationship and pull-out behaviour

- Bond is caused by adhesion, friction and end hooks (fibre deformation)
- The anchorage effect of hooked ends is typically considered as contribution to bond (higher nominal bond stresses)
- Usual assumption: Constant bond shear stresses over fibre length, rigid-plastic bond shear stress-slip relationship
- Differential equation for bond shear stress - slip relationship assuming linear elastic behaviour of fibre and matrix

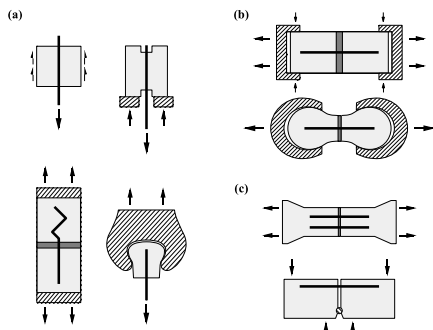

· Faserausziehversuche – schematische Versuchsanordnungen nach Bartos [16] und Gray [39]: (a) Einzelfasern mit einseitigem Verbund; (b) Einzelfasern mit beidseitigem Verbund; (c) Fasergruppen mit beidseitigem Verbund.

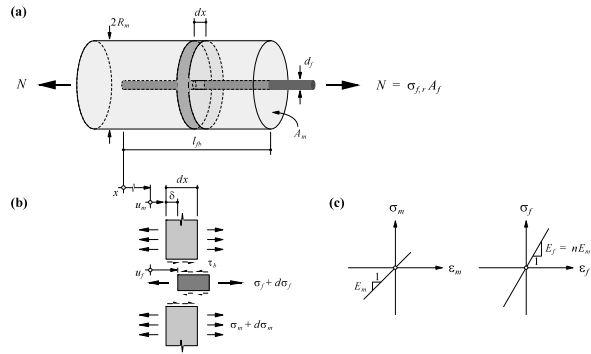

**Bild 2.3** – Faserausziehversuch: (a) Prinzipskizze; (b) Verschiebungen und Spannungen am differentiellen Element; (c) Spannungs-Dehnungsbeziehungen.

Bond between the steel fibres and the cement matrix is mainly caused by adhesion and friction. Hooked (or coned) ends contribute to a mechanical anchorage of the fibres at the end. Usually, those effects are smeared over the fibre length as a uniform nominal bond shear stress.

Similarly to conventionally reinforced concrete, the bond shear stress-slip relationship can be established assuming a linear elastic behaviour of the fibres and the matrix, which leads to a closed-form analytical solution.

Various methods exist for the experimental determination of the bond shear stresses, where normally the fibre is pulled-out of the matrix (see Figure in the slide).

# Mechanical behaviour of single fibre in cement matrix

## Marti and Pfyl's simplified model for fibre activation and pull-out

- Rigid bond shear stress-slip relationship between fibre and matrix over embedment length  $l_{fb}$
- Once the bond shear stresses are fully activated, the fibre is pulled out of the matrix (on the shorter embedded side)
- Simplification: Only the slip contributes to the crack width
- Linear softening due to decreasing bond length of fibre

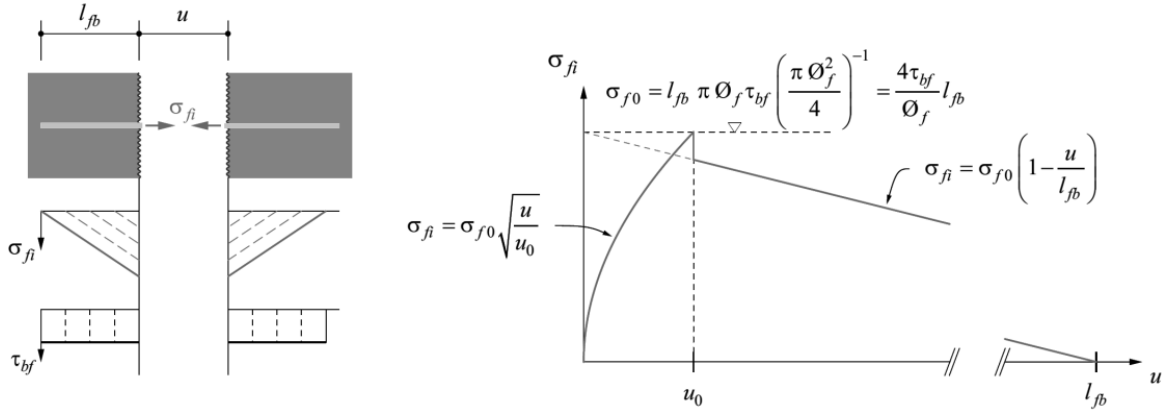

Marti and Pfyl [1] suggested a simplified model for the estimation of the tensile stress in a straight fibre pulled out of a cement matrix. A constant bond shear stress is assumed (as long as fibre stays elastic, similar as in the tension chord model). The fibre stress is normally given as a function of the crack opening. It is assumed that the fibres are ineffective until cracking of the concrete.

**Fibre activation:** With increasing fibre stress after cracking, the bond shear stress gets activated over an increasing length of the fibre starting from the crack face. The displacement can be calculated from the integration of elastic strains of the fibre over its length.

**Fibre pull-out:** Once the bond length is fully activated, the fibre is pulled out. For simplicity, only the slip caused by the pull-out is assumed to contribute to the crack opening. This leads to a linear decrease of the fibre stress with increasing crack opening until it eventually reaches zero at the complete pull-out.

# Fibre content and orientation factor

## Cement matrix with randomly distributed fibres

- The fibre content of SFRC is measured by the weight of the fibres per volume of the concrete mix [ $\text{kg}/\text{m}^3$ ] or the fibre volume fraction  $V_f$  ( $78.5 \text{ kg}/\text{m}^3 \leftrightarrow V_f = 1\%$ )
- Higher fibre dosages lead to difficulties in the workability and applicability of the concrete mix.
- In the mixing process, fibres theoretically distribute equally and with random directions in the cement matrix.
- However, due to the casting process, fibres are usually unevenly distributed and oriented in practice
- Fibres are inclined to the crack face at arbitrary angles
- Fibre stresses at cracks are assumed to be aligned with the direction of the crack face displacement ( $E_f \rightarrow 0$ )

Typical fibre contents [ kg / m <sup>3</sup> ]	
< 20	uneconomic, ineffective
20-50	Most commonly used fibre content
50-100	Highly fibre reinforced, expensive
> 100	Problematic due to limited workability

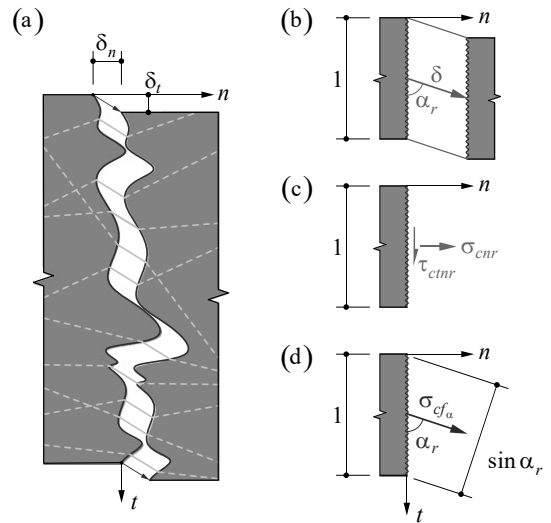

The steel fibres are added to the concrete while mixing, which leads to a random distribution and alignment in the concrete volume. Therefore, the fibres are generally not aligned with the crack direction nor with the crack kinematics. Still, the fibre stresses at the cracks are assumed to be aligned with the direction of the crack face displacement (fibre bending stiffness  $\rightarrow 0$ ).

The random distribution and orientation of the fibres are accounted for with the fibre orientation factor, see following slides.

# Fibre content and orientation factor

## Fibre orientation factor in 2D (thin elements)

- All fibres randomly orientated in 2D-plane. All directions have equal probability of occurrence.
- Fibres with very low inclination to the normal plane are assumed to be ineffective (also in 3D, next slide)
- Number of fibres crossing the crack per unit length (effective fibres) =  $\cos\theta$  → projection of fibre end loci on crack (also in 3D)

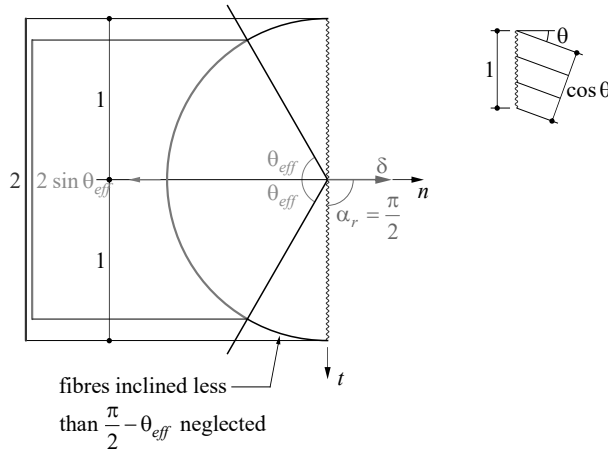

Semi-circle = loci of fibre ends with equal probability: length  $\pi$  (for crack length with  $r = 1$ )

→ Fibre orientation factor = length of sector, projected on crack (or equivalent integral), divided by length of semi-circle:

$$K_f = \frac{1}{\pi} \int_{-\theta_{eff}}^{\theta_{eff}} \cos\theta d\theta = \frac{2 \sin\theta_{eff}}{\pi}$$

$$\theta_{eff} = \frac{\pi}{2}: K_f = \frac{2}{\pi} \quad \theta_{eff} = 60^\circ: K_f = \frac{\sqrt{3}}{\pi}$$

First, a 2D fibre orientation is assumed, i.e., assuming that the fibres are lying in the  $(n, t)$ -plane, where  $n$  is the normal to the crack face (green corrugated line). In this case, the fibre effectiveness for orthogonally opening cracks is investigated, which means that the displacement vector is parallel to the normal to the crack plane. Given the assumption that there are  $N$  fibres crossing the crack plane and all inclinations between  $-\pi/2$  and  $\pi/2$  have the same probability of occurrence, the number of fibres crossing the crack plane at an inclination between  $\theta$  and  $\theta+d\theta$  is

$$N \cdot \cos(\theta) \cdot \frac{d\theta}{\pi}$$

The fibre orientation factor then follows by integration over the range of inclinations for which fibres are assumed to be effective, and dividing by the total number of fibres  $N$ . Usually, very flat inclinations to the normal plane (less than  $30^\circ$ ) are assumed to be ineffective.

The same result can be derived from the fraction of the length of the effective sector projected on the crack plane to the length of the semi-circle (see slide).

# Fibre content and orientation factor

## Fibre orientation factor in 3D

- Fibres randomly orientated in 3D-plane. All directions have equal probability of occurrence.
- Consideration of semi-sphere and projection on crack plane

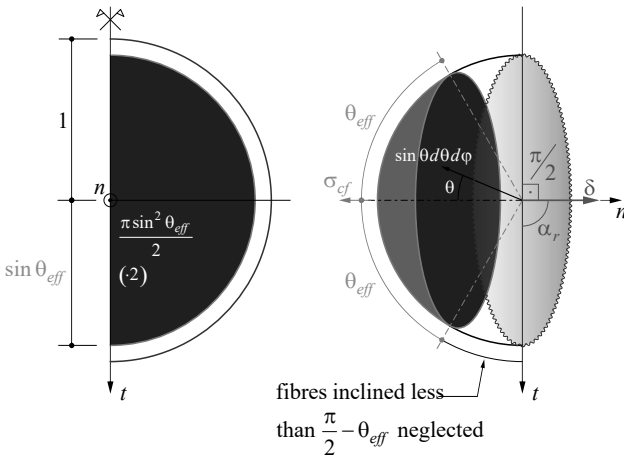

- Semi-sphere = loci of fibre ends with equal probability,  $A = 2\pi$  (for crack surface with  $r = 1$ )
- Number of fibres with inclination  $\theta$  crossing crack plane

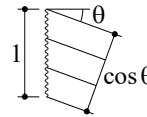

→ Fibre orientation factor = surface of spherical sector, projected to crack plane  $n$  (or equivalent integral), divided by surface of semi-sphere:

$$K_f = \frac{1}{2\pi} \int_0^{2\pi} \int_0^{\theta_{eff}} \cos \theta \sin \theta \, d\theta \, d\varphi = \frac{\sin^2 \theta_{eff}}{2}$$

$$\theta_{eff} = \frac{\pi}{2}: K_f = \frac{1}{2}; \quad \theta_{eff} = \frac{\pi}{3} = 60^\circ: K_f = \frac{3}{8}$$

The same principles can be applied to a 3D fibre orientation. The semi-circle of the 2D-problem is now a hemisphere (rotationally symmetric). The number of fibres crossing the crack plane at any inclination for  $\theta$  between  $-\pi/2$  and  $\pi/2$  and  $\varphi$  between  $0$  and  $2\pi$ , for a total number of  $N$  fibres is as follows:

$$N \cdot \cos(\theta) \cdot \sin(\theta) \frac{d\theta \cdot d\varphi}{2\pi}$$

The fibre orientation factor is defined by the integral over all effective fibre inclinations (fibres inclined less than  $\pi/2 - \theta_{eff}$  are assumed to be ineffective and therefore, neglected).

The same result can be obtained from the projected surface of the effective spherical sector divided by the surface of the hemisphere.

# Mechanical behaviour of SFRC

## SFRC members in tension

- Pre-cracking behaviour is not (marginally) influenced by fibres, stiffness of matrix is governing
- After cracking, the fibres transfer stresses across the cracks.
- Tensile stresses after cracking → superposition of fibres and matrix (note: the softening of plain concrete in tension is much more pronounced than the pull-out of the fibres → matrix only relevant initially, at very small crack openings)

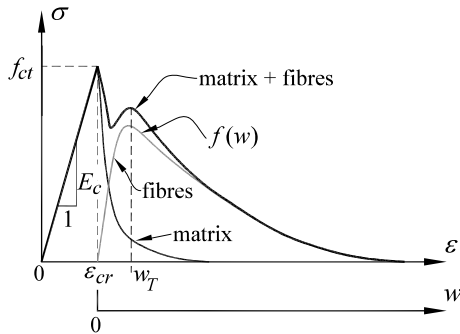

Figure 3.1. Stress versus crack COD ( $w$ ) for SFRC.

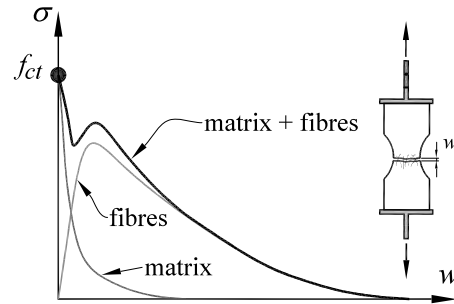

Figure 2.1. Stress versus Crack Opening Displacement (COD),  $w$  for SFRC.

[ Source: Amin, 2015 ]

As stated before, the fibre stress is assumed to be activated by the pull-out of the fibres from the matrix, which only happens after cracking. Therefore, the addition of fibres has hardly any influence on the pre-cracking behaviour.

The concrete cracks when reaching its tensile strength. After cracking, the tensile stresses result from the superposition of fibres and matrix. Due to the profound softening of plain concrete in tension, stresses usually drop after the formation of cracks since the fibres are only activated by the crack opening. After full activation of the bond shear stresses along the embedment length, the fibres are pulled out, causing softening behaviour of SFRC in tension.

# Mechanical behaviour of SFRC

## Marti and Pfyf's simplified model for fibre activation and pull-out in tension → «fibre effectiveness» $\sigma_{cf0}$

- Simplified but sufficiently accurate assumptions for activation and pull-out
- Slip is neglected until all fibres in the cross section are fully activated (→ elliptic curve)
- After full activation of the fibres, only pull-out contributes to crack opening (→ hyperbolic)

Note: Unlike the fibre stress  $\sigma_f$ ,  $\sigma_{cf}$  and  $\sigma_{cf0}$  are referred to the concrete surface (→ vol. fibre content  $\rho_f$ , fibre orientation factor)

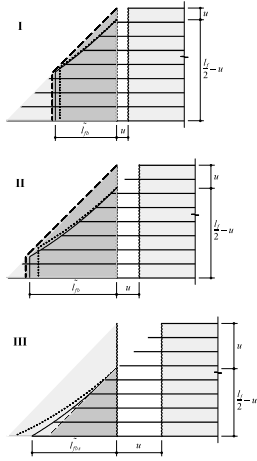

$\rho_f$  : fibre content (volume)  
 $K_f$  : fibre orientation factor

av. embedment :  $\left. \begin{matrix} \max & \frac{l_f}{2} \\ \min & 0 \end{matrix} \right\} \rightarrow \frac{l_f}{4}$

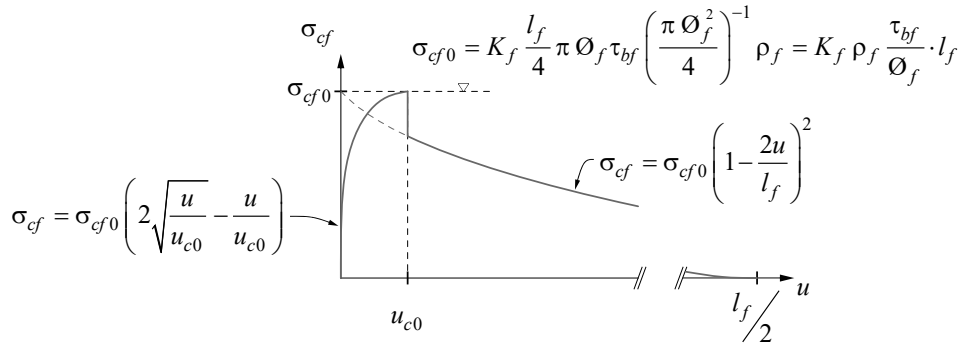

The simplified model for the pull-out of a single fibre (slide 10) can be adapted for SFRC members in tension. Again, an orthogonally opening crack is considered. The fibres are assumed to be randomly distributed in the concrete volume, with equal probability of occurrence for all inclinations of the fibres. The embedment length for fibres crossing a crack varies between 0 and  $l_f/2$  (since for longer embedment lengths the opposite side of the crack would be governing). The average embedment length for a random fibre distribution is therefore  $l_f/4$ , which is used for the estimation of the (maximum) fibre effectiveness  $\sigma_{cf0}$ . If as usual, the fibre stresses are referred to the concrete cross-section (rather than the steel fibres cross-section), the fibre content  $\rho_f$  and the fibre orientation factor  $K_f$  (derived in slide 12-13) are applied.

Slip is neglected until the full activation of the fibre with the longest embedment length. The displacement in the fibre activation phase is determined by integration of the elastic strains over the embedment length. After full activation, only the slip from the pull-out is accounted for when calculating the crack opening. Fibres with shorter embedment lengths are successively pulled out and do not contribute any longer to the effective fibre stress, which therefore decreases hyperbolically until eventually reaching zero when the longest embedded fibre is pulled out (i.e., at a crack opening corresponding to half the fibre length).

# Mechanical behaviour of SFRC

## Strain softening and damage localization in SFRC

- The softening behaviour of fibres being pulled out of the cement matrix results in the concentration of deformations = localisation in one single crack after exceeding the cracking load.
- Depending on the amount of fibres (very high dosages) and the fibre activation mechanism, tension chords under uniaxial loading can also show a hardening post-cracking behaviour, with multiple cracks before reaching the peak load where localisation starts (typical in some ultra-high performance fibre reinforced concrete mixes).

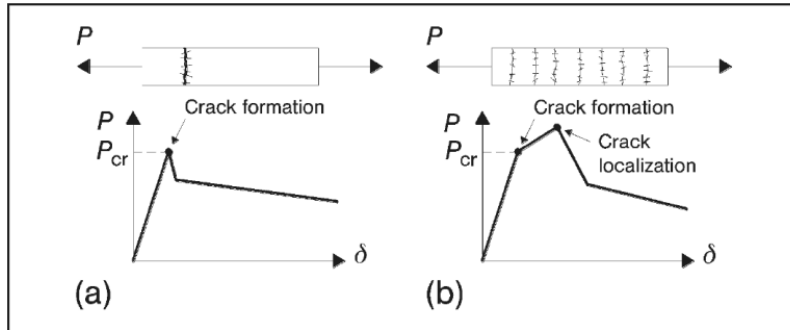

**Figure 5.6-2:** Softening (a) and hardening (b) behaviour in axial tension

[ Source: fib Model Code, 2010 ]



# Mechanical behaviour of SFRC

## Mechanical model for softening behaviour / strain localisation: Fictitious crack model (Hillerborg)

1. Linear elastic  $\sigma$ - $\epsilon$ -relationship in elastic phase up to limiting strain  $\epsilon_f$
2. With increasing deformation, a fracture zone develops and the stress  $\sigma$  decreases (cracking zone:  $\sigma$ - $w$  relationship = energy dissipation)
3. Any additional elongation is concentrated in the fracture zone (= localisation); stress and strain decrease in adjacent unloading parts (energy release)

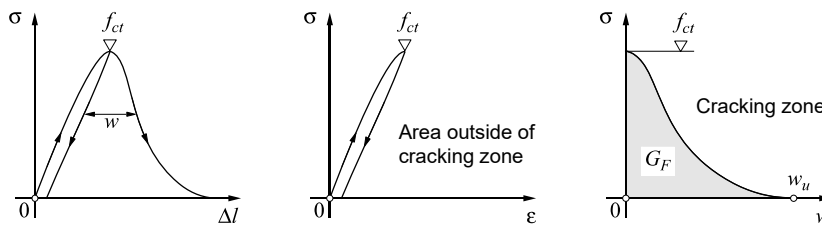
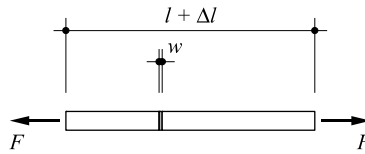

[ Source: Sigrist, 1995 ]

08.12.2021

ETH Zurich | Chair of Concrete Structures and Bridge Design | Advanced Structural Concrete

17

The softening behaviour of steel fibre reinforced concrete after cracking typically leads to a localisation of deformations in the fracture zone. A simple model for the load-deformation behaviour of strain softening materials such as plain or fibre reinforced concrete is the Fictitious Crack Model established by Hillerborg.

In the elastic loading phase, the conventional stress-strain-relationship is applicable up to a limiting strain  $\epsilon_f$ , where the material strength is reached. At this load, the specimen fails in a brittle manner under load control (monotonically increasing load). Under deformation control (monotonically increasing imposed elongation), the post-peak response can be determined if the testing machine is stiff and the specimen small, as follows (assuming an infinitely stiff test rig):

- At the peak load, a *fracture zone* develops. Typically, the load is assumed to decrease with increasing displacements, e.g. linearly or hyperbolically.
- According to Hillerborg's model, a negligibly small extension of the fracture zone – a «fictitious crack» – is assumed, whose behaviour is modelled by a (residual) stress-displacement relationship (as opposed to conventional stress-strain relationships known from continuum mechanics). The area under the load-displacement curve of the fracture zone is the *fracture energy*  $G_F$ .
- Since the load decreases with increasing elongation of the fracture zone (= opening of the fictitious crack), the undamaged areas outside the fracture zone unload elastically. Hence, the deformations localise in the fracture zone; the unloading parts of the specimen even shorten.

The fracture of plain concrete and SFRC can be modelled with the fictitious crack model. In plain concrete, the fracture energy depends on the tensile strength of the concrete, the aggregate size and other parameters, and residual stresses vanish at very small crack openings (< 1 mm). In SFRC, the stress-crack opening relationship can be used as characteristic of the fracture zone. The fracture energy is orders of magnitude higher than in plain concrete, and residual stresses vanish only at large crack openings (half fibre length).

# Mechanical behaviour of SFRC

## Mechanical model for softening behaviour / strain localisation: Fictitious crack model (Hillerborg)

- Hillerborg's fictitious crack model can be used to analyse materials with strain-softening behaviour such as SFRC
- It provides a direct explanation of the size effect observed in experiments: Fracture energy  $G_f$  is considered constant, but elastic energy in unloading parts, released at fracture, increases with specimen size
  - the unloading branch can be observed in short specimens ( $l < l_{cr}$ ) in deformation controlled tests
  - long specimens ( $l > l_{cr}$ ) fail in a brittle manner at the peak load even in deformation control
- Alternatively, smeared «crack band» models may be used (assumed crack band width → mesh dependency in FE analyses)

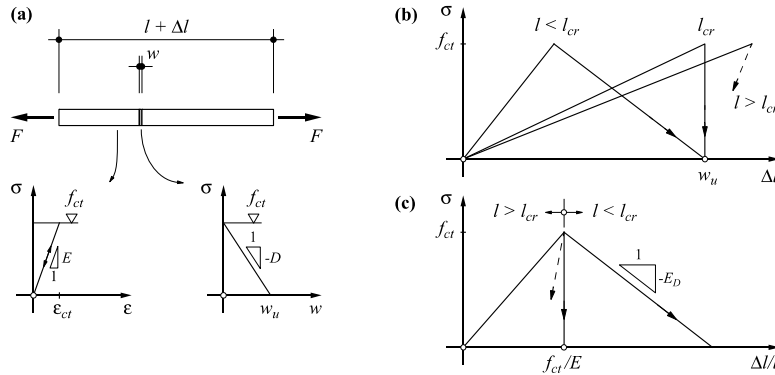

[ Source: Sigrist, 1995 ]

The overall load-deformation behaviour is not only dependent on the material characteristics (stress-strain relationship of the undamaged material and stress-displacement relationship of the fracture zone), but depends on the specimen length (size effect) and, in general, on the characteristics of the entire system.

The undamaged parts of the specimen shorten at unloading after the peak load, while the fracture zone elongates. Depending on the length and elastic stiffness of the undamaged parts and the softening (negative) stiffness of the fracture zone, a post-peak response can be obtained or a brittle failure occurs even in deformation control (and even with an infinitely stiff testing rig).

# Mechanical behaviour of SFRC

## Strain softening and deformation hardening

- Structures can have different responses under different loading conditions (depending on size and structural configuration)
- Even if a softening response is observed in tension, using the same SFRC mix strain hardening may be achieved in bending (particularly if biaxial load transfer is possible)

### Note:

Other than in most laboratory tests, real structures are not loaded in displacement control, i.e., the load will not drop if the structure «softens». Hence, isostatic «softening SFRC» structures WILL COLLAPSE at cracking.

In such cases, the length of the softening branch (often erroneously called «ductility») essentially does not matter – the failure is brittle.

However, if alternate load paths are possible, i.e. in hyperstatic structures (internally or externally), softening structural elements (with long softening branch) may significantly contribute to the load carrying mechanism when softening.

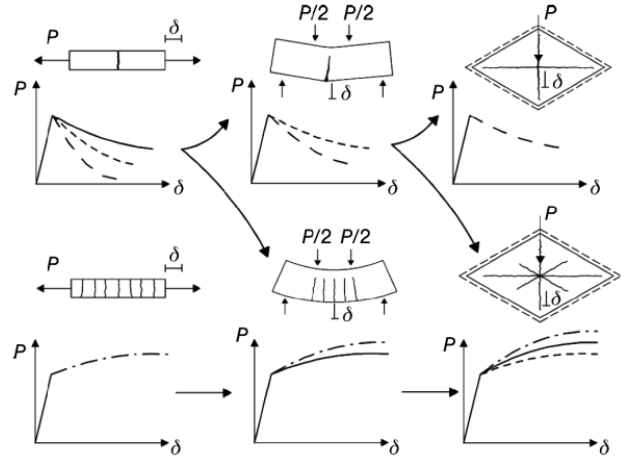

[ Source: fib Model Code, 2010 ]

(notes see slide)

# Mechanical behaviour of SFRC

## SFRC members in bending

- After cracking, the stress distribution in the cracked section depends on the crack opening
- It is assumed that the crack opening varies linearly over the cracked depth (rotation  $\theta$ )
- A linear strain distribution is assumed ... in the uncracked cross sections (at distances  $\pm s_r/2$  from crack) ... in the uncracked part of the cracked section ... along the compression face
- The value of  $s_r$  (crack element length / "characteristic length") varies strongly in experiments. It can be estimated as  $s_r \approx d$ .
- Crack opening parameter  $\xi$  ( $\xi = 1$ : all fibres at bottom of cross-section pulled out):

$$\xi = \frac{2 \cdot \theta \cdot (h - z_c)}{l_f}$$

(at crack opening  $l_f/2 \rightarrow$  hardly ever achieved)

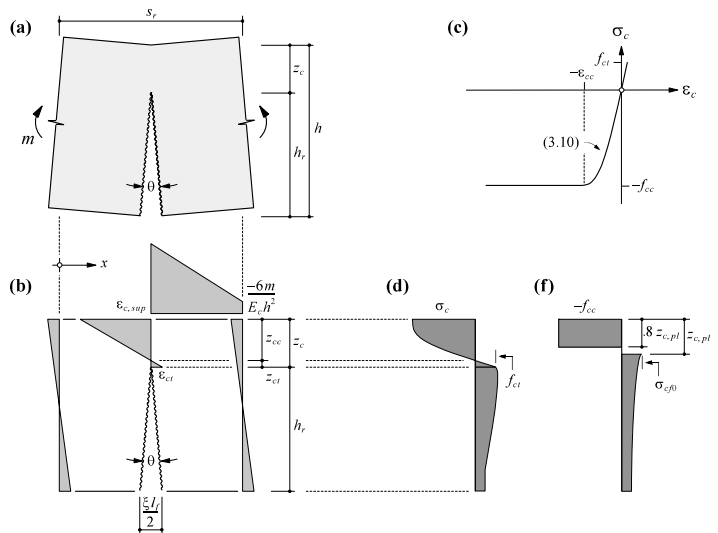

[ Source: Pfy, 2003 ]

(notes see slide)

# Mechanical behaviour of SFRC

## SFRC members in bending

- The crack width can be determined by integrating the concrete strains over the distance  $\pm s_r/2$  (crack element):

$$w = \theta \cdot (h - z_c) = \frac{s_r}{2 \cdot z_c} \cdot \left( \frac{6 \cdot m}{E_c \cdot h^2} - \varepsilon_{c,sup} \right) \cdot (h - z_c)$$

- Integration of the stresses over the cross section yields the average stresses and the respective centroids for the cracked and uncracked parts of the cross section. Considering only the fibre pull-out phase and Pfyf's model, one gets:

$$\xi = \frac{2 \cdot \theta \cdot (h - z_c)}{l_f} \quad \sigma_{crm} = \frac{1}{h - z_c} \cdot \int_0^{h-z_c} \sigma_{cf}(z) \cdot dz = \sigma_{cf0} \cdot \frac{\xi^2 - 3 \cdot \xi + 3}{3} \quad \sigma_{ccm} = \frac{1}{z_c} \cdot \int_{-z_c}^0 \sigma_{cc}(z) \cdot dz$$

$$\frac{\sigma_{cf}(z)}{\sigma_{cf0}} = 1 - \left( \frac{\xi \cdot z}{h - z_c} \right)^2 \quad \zeta_{ct} = \frac{1}{\sigma_{crm} \cdot (h - z_c)} \cdot \int_0^{h-z_c} \sigma_{cf}(z) \cdot dz = (h - z_c) \cdot \frac{3 \cdot \xi^2 - 8 \cdot \xi + 6}{4 \cdot \xi^2 - 12 \cdot \xi + 12} \quad \zeta_{cc} = \frac{1}{\sigma_{ccm} \cdot z_c} \cdot \int_{-z_c}^0 \sigma_{cc}(z) \cdot z \cdot dz$$

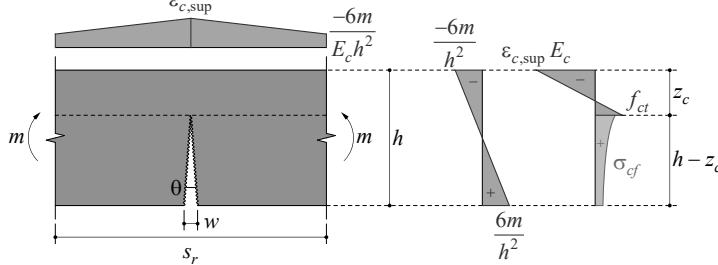

$$\sum F_H: \quad \sigma_{crm} \cdot (h - z_c) + \sigma_{ccm} \cdot z_c = 0$$

$$\sum M: \quad m = \sigma_{crm} \cdot (h - z_c) \cdot \zeta_{ct} + \sigma_{ccm} \cdot z_c \cdot \zeta_{cc}$$

→ assume value of  $w$

→ solve equations for  $z_c(w)$ ,  $\varepsilon_{c,sup}(w)$ ,  $m(w)$

Unlike conventionally reinforced concrete members, SFRC members in bending cannot be analysed at a single discrete cross section due to the dependence of the fibre stresses on the crack opening. For the assessment of the bending moment for a given crack opening  $w$ , one has to consider a cracked segment. The crack spacing has to be estimated and usually lies between 0.5 and 2  $d$ .

The crack opening angle can be estimated by integration of the strains in the compression chord, assuming linear elastic behaviour of the concrete at the centre section between adjacent cracks and a linear distribution of the strains. Further assuming straight crack faces and using Pfyf's pull-out model for the fibre stress-crack opening-relationship leads to a proper mechanical formulation of the stress distribution over the cracked cross section. The formulas can be numerically solved for the bending moment for a given crack opening  $w$ . A closed analytical formulation is not possible.

Note that this model is only valid for deflection softening behaviour of SFRC beams in bending, which is usually the case for typical fibre contents and geometries.

# Mechanical behaviour of SFRC

## SFRC members in bending

- Further simplifications are possible if the depth of the compression zone is determined as in conventional reinforced concrete (rectangular stress block under  $f_{cd}$  acting over  $0.8 z_c$ , as shown in slide 32):

$$z_c = \frac{h}{1 + \frac{2.4 f_{cd}}{\sigma_{cf0} (\xi^2 - 3 \cdot \xi + 3)}} \quad m = 0.8 f_{cd} z_c \left[ 0.6 z_c + (h - z_c) \frac{3 \cdot \xi^2 - 8 \cdot \xi + 6}{4 \cdot \xi^2 - 12 \cdot \xi + 12} \right] \quad (0 \leq \xi \leq 1)$$

$$z_c = \frac{h}{1 + \frac{2.4 f_{cd} \xi}{\sigma_{cf0}}} \quad m = 0.8 f_{cd} z_c \left[ 0.6 z_c + (h - z_c) \frac{h - z_c}{4 \xi} \right] \quad (\xi > 1)$$

NB: The activated strength in the fibres might not reach the required strains for the approximation with a rectangular stress block!

- In many cases, the compression zone depth may be fully neglected without significantly affecting the bending moment, yielding the even simpler expressions:

$$z_c = 0 \quad m = \frac{\sigma_{cf0} h^2 (3 \cdot \xi^2 - 8 \cdot \xi + 6)}{12} \quad (0 \leq \xi = \frac{2\theta h}{l_f} \leq 1)$$

$$z_c = 0 \quad m = \frac{\sigma_{cf0} h^2}{12 \cdot \xi^2} \quad (\xi > 1)$$

These expressions are useful to determine (estimate) the fibre effectiveness directly from bending tests.

(notes see slide)

# Mechanical behaviour of SFRC

## SFRC members in bending

- The fib Model Code [3] proposes 3- or 4-point-bending-tests for the inverse analysis of the fibre stress - pull-out behaviour.
- A notch in the prism pre-determines the location of the crack and simplifies the measurement of the crack width.
- Modern measurement technologies – e.g. digital image correlation – allow the measurement of the crack kinematics for continuous SFRC beams. This is especially useful for members with deformation hardening, where multiple cracks occur.

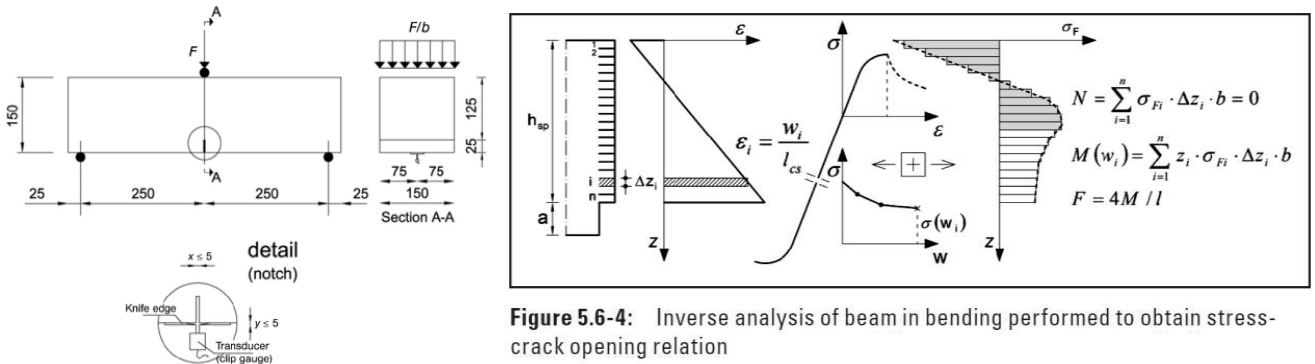

Figure 5.6-4: Inverse analysis of beam in bending performed to obtain stress-crack opening relation

[ Source: fib Model Code, 2010 ]

(notes see slide)

# Mechanical behaviour of SFRC

## SFRC members in compression

- Steel fibres do not significantly affect the compression strength
- Ductility is improved in post-peak behaviour
- Fibres prevent “explosive” failure and excessive spalling (may be useful / relevant in high strength concrete)

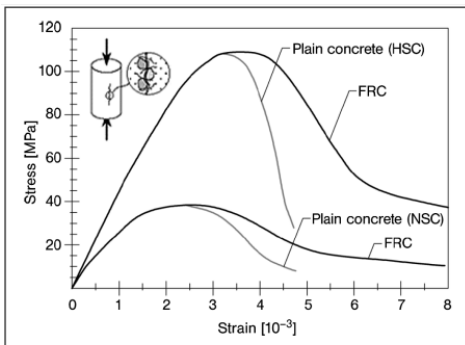

Figure 5.6-3: Main differences between plain and fibre reinforced concrete having both normal and high strength under uniaxial compression

[ Source: fib Model Code, 2010 ]



Bild 3.5 – Spannungs-Stauchungsdiagramme für Betone mit unterschiedlichem Fasergehalt  $C_f$  aus [105] (Stahlfaser mit Endhaken,  $l_f = 35$  mm,  $l_f/d_f = 65$ ).

[ Source: Pfy, 2003 ]

The behaviour of concrete in uniaxial compression is usually investigated with cylinders (300 mm height, 150 mm diameter). Plain concrete behaves approximately linear elastically for low strains. With increasing load, the concrete starts to fail by the progression of microcracks between aggregates and matrix, caused by transverse stresses. In deformation controlled tests, this causes a decrease of compressive stresses after reaching the peak strength.

Similar as in uniaxial tension, the addition of fibres only affects the behaviour after cracking. Therefore, the compressive strength of the concrete is not significantly affected. Tensile stresses in the fibres are however activated with increasing pull-out of the fibres, which counteracts the further opening of the cracks. This allows the concrete to reach higher strains in the post-peak range (higher ductility).

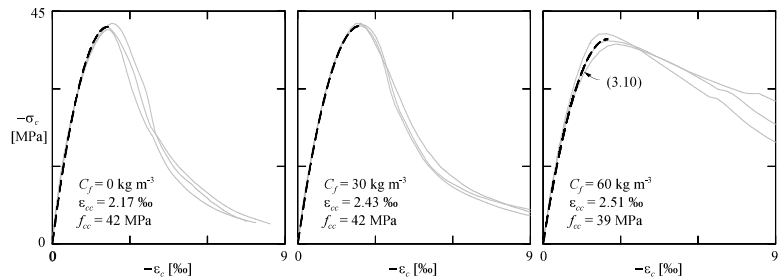
Fibres are also beneficial for high-strength concrete, which are prone to explosive spalling of non-confined concrete (e.g. concrete cover) due to their brittle failure at higher strength (higher release of elastic energy). PP fibres are also useful under fire loads, see separate chapter on fire design.



# Mechanical behaviour of SFRC

## SFRC members in shear

- The addition of steel fibres generally has similar effects on the structural behaviour as in tension and in bending.
- Combined with stirrups, steel fibres contribute to the shear resistance. Unfortunately, current design rules for beams with SFRC reinforcement are typically semi-empirical, using additive terms ( $\ll V_{Rd} = V_c + V_s + V_f \gg$ ).
- These semi-empirical approaches postulate that the peak resistances of stirrups and steel fibres are reached at different crack openings. Therefore, the maximum total shear resistance is lower than the sum of the individual peak resistances.
- Tests indicate that fibres may be used as only shear reinforcement (without stirrups), and compression field analyses indicate that a hardening behaviour may be achieved with SFRC mixes softening in tension (beneficial effect of crack reorientation, i.e. flatter cracks activating more fibres); however, experimental evidence (practical fibre dosages) is scarce.

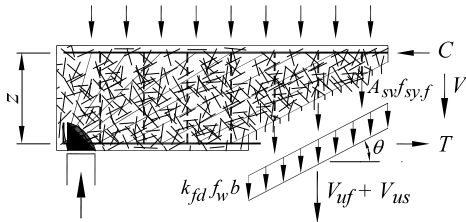
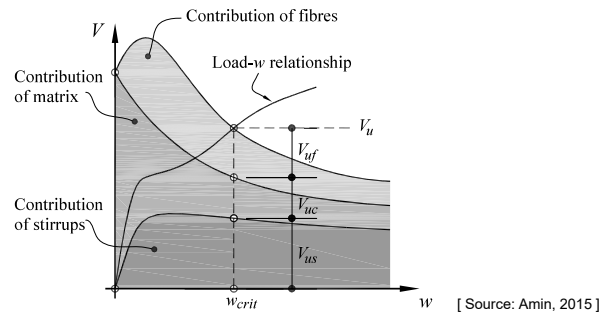

Figure 5.53. Transverse and fibre reinforcing components of SFRC beams with stirrups failing in shear (Foster, 2014).



# Mechanical behaviour of SFRC

## SFRC members in shear

- Idealising the fibre reinforcement as rigid-perfectly plastic material (assuming a conservative residual fibre stress  $f_{fd}$  as "yield stress"), the shear strength can be determined as for conventionally reinforced girders by superposition.
- However, this model has not been experimentally validated sufficiently to be applied in design (ongoing research at the Chair of Concrete Structures and Bridge Design).

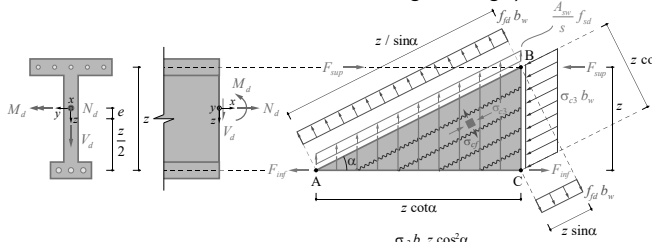

- Resistance of reinforcement 
$$V_{Rd,s} = \left( \frac{A_{sw}}{s} f_{sd} + f_{fd} b_w \right) z \cot \alpha$$
- Resistance of concrete compression field 
$$V_{Rd,c} = b_w (k_c f_{cd} + f_{fd}) z \sin \alpha \cos \alpha$$
  

$$V_{Rd} = \min \{ V_{Rd,s}, V_{Rd,c} \}$$
- Longitudinal tensile force resulting from the shear force  $F_t(V_d)$  is resisted equally by the compression and tension chord

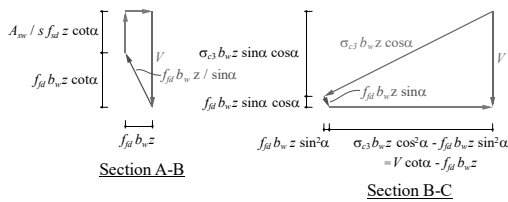

$$F_{sup} = \frac{M_d - N_d e}{z} - \frac{N_d}{2} - \frac{V_d \cot \alpha - f_{fd} b_w z}{2}$$

$$F_{inf} = \frac{M_d - N_d e}{z} + \frac{N_d}{2} + \frac{V_d \cot \alpha - f_{fd} b_w z}{2}$$

# Hybrid reinforcement (SFRC and conventional reinforcing bars)

## Modified tension chord model

- Equilibrium at crack with residual tensile strength  $\sigma_{cf}$

$$f_{ct} \cdot (1 - \rho_s + n \cdot \rho_s) = \sigma_{cf} \cdot (1 - \rho_s) + \sigma_{sr} \cdot \rho_s$$

- Maximum crack spacing

$$s_{r0} = \frac{\emptyset \cdot f_{ct} \cdot (1 - \rho_s)}{2 \cdot \tau_{bs} \cdot \rho_s} \cdot \left( 1 - \frac{\sigma_{cf}(w)}{f_{ct}} \right)$$

- Crack width

$$w = s_r \cdot (\epsilon_{sm} - \epsilon_{cm}) = \frac{s_r^2 \cdot \tau_{bs}}{\emptyset \cdot E_s} \cdot \left( 1 + n \cdot \frac{\rho_s}{1 - \rho_s} \right)$$

- Minimum reinforcement ratio

$$\rho_{s,min} = \frac{f_{ct} - \sigma_{cf}(w)}{f_{sy} - \sigma_{cf} - f_{ct} \cdot (n - 1)}$$

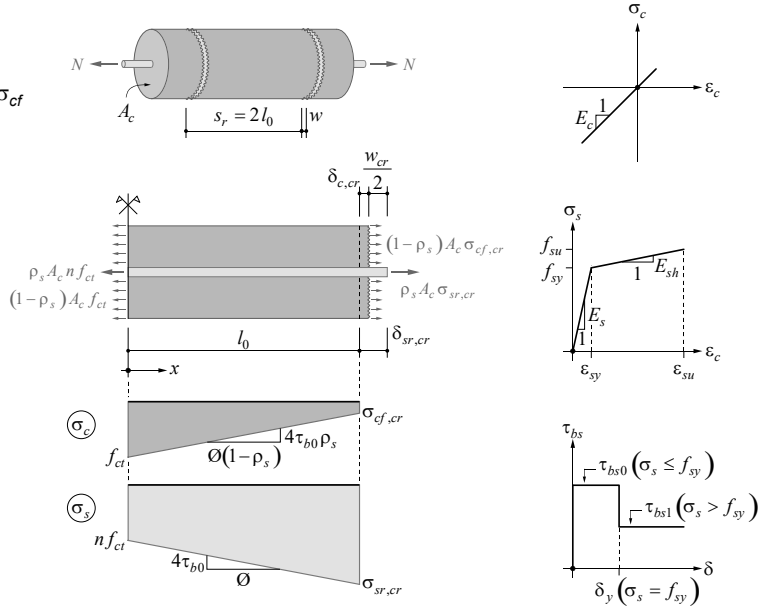

Steel fibres can be used effectively in combination with conventional reinforcing bars (hybrid reinforcement). The addition of fibres can be mechanically modelled by modifying the Tension Chord Model (known from Stahlbeton I), which is a physically consistent tool to model the load-deformation behaviour of structural concrete members in tension.

Consider a tension tie with the cross sectional area  $A_c$  (gross area, including reinforcement cross-section) for the concrete, reinforced with steel fibres and a single reinforcing bar with diameter  $\emptyset$ . In the uncracked state, the tension tie behaves linearly elastic, with perfectly rigid bond between concrete and reinforcement, and cracks at a load of  $N = f_{ct} \cdot (1 - \rho_s + n \cdot \rho_s)$ . Rather than assuming stress-free cracks as in the conventional TCM for reinforced concrete, where forces are only transferred across the cracks by the reinforcing bar, the residual tensile stresses activated by the pull-out of the fibres in tension (see slide 15) contribute to the stress transfer across the cracks. This leads to a new formulation of equilibrium just before and after the formation of a crack.

The bond shear stress-slip relationship between the concrete and the reinforcing bar is assumed to remain the same as for plain concrete (bond shear stresses depending on whether the reinforcing bar is elastic or yielding). The smaller possible increase in concrete stresses (from  $\sigma_{cf}$ , instead of zero, at the crack to a maximum of  $f_{ct}$  at the centre between cracks) therefore leads to smaller crack spacings. The crack width can be determined by integration of the average steel and concrete strains as in conventionally reinforced concrete. This leads to a recursive formulation since the fibre stress, required for the calculation of the crack spacing, depends the crack opening, which can be solved iteratively.

# Hybrid reinforcement (SFRC and conventional reinforcing bars)

## Modified tension chord model

- Crack width and crack spacing are interdependent ( $\sigma_{cf}$  depends on crack opening) → iterative solution procedure.
- As an approximation, the residual tensile strength  $\sigma_{cf}$  (at a chosen crack opening) or even the fibre effectiveness  $\sigma_{cf0}$  can be used, which normally leads to reasonable results.

$$s_{r0} = \frac{\emptyset \cdot f_{ct} \cdot (1 - \rho_s)}{2 \cdot \tau_{bs} \cdot \rho_s} \cdot \left(1 - \frac{\sigma_{cf0}}{f_{ct}}\right) \quad \sigma_{cf0} = K_f \cdot \rho_f \cdot \frac{\tau_{bf}}{\emptyset} \cdot l_f$$

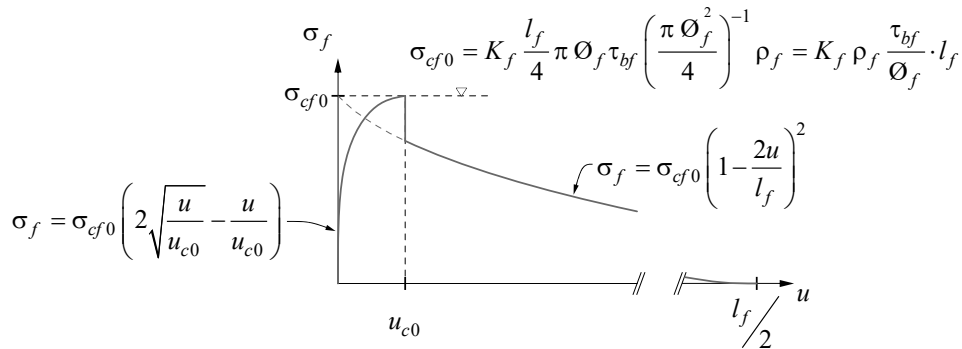

As an approximation, the fibre effectiveness  $\sigma_{cf0}$  may be used, which usually leads to reasonable results.

# Hybrid reinforcement (SFRC and conventional reinforcing bars)

## Steel stress and average strains according to tension chord model

- Neglecting the deformation of concrete between cracks, the crack widths can be determined from the average steel strains, which are obtained according to the tension chord model.

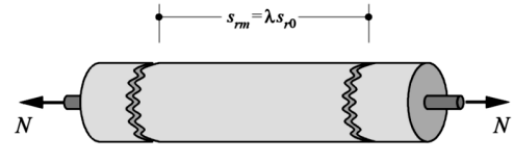

Reinforcement is partially elastic and partially plastic:  $f_s \leq \sigma_{sr} \leq \left( f_s + \frac{2\tau_{bs1}S_r}{\emptyset} \right)$

$$\varepsilon_{sm} = \frac{(\sigma_{sr} - f_s) \emptyset}{4E_{sh}\tau_{bs1}S_r} \left( 1 - \frac{E_{sh}\tau_{bs0}}{E_s\tau_{bs1}} \right) + \frac{(\sigma_{sr} - f_s)\tau_{bs0}}{E_s\tau_{bs1}} + \left( \varepsilon_{sy} - \frac{\tau_{bs0}S_r}{E_s\emptyset} \right)$$

$$\sigma_{sr} = f_{sy} + 2 \cdot \frac{\frac{\tau_{bs0} \cdot S_r}{\emptyset_s} \cdot \sqrt{\left( f_{sy} - \varepsilon_{sm} \cdot E_s \right) \cdot \frac{\tau_{bs1} \cdot S_r}{\emptyset_s} \cdot \left( \frac{\tau_{bs0}}{\tau_{bs1}} - \frac{E_s}{E_{sh}} \right) + \frac{\tau_{bs0} \cdot \tau_{bs1} \cdot S_r^2 \cdot E_s}{\emptyset_s^2 \cdot E_{sh}}}}{\frac{\tau_{bs0}}{\tau_{bs1}} - \frac{E_s}{E_{sh}}}$$

Reinforcement is fully plastic:  $\left( f_s + \frac{2\tau_{bs1}S_r}{\emptyset} \right) \leq \sigma_{sr} \leq f_t$

$$\varepsilon_{sm} = \varepsilon_{sy} + \frac{(\sigma_{sr} - f_s)}{E_{sh}} - \frac{\tau_{bs1}S_r}{E_{sh}\emptyset} \quad (\text{bare steel} - \Delta\varepsilon_1, \Delta\varepsilon_1 = \frac{\tau_{bs1}S_r}{E_{sh}\emptyset}) \quad \sigma_{sr} = f_{sy} + \left( \varepsilon_{sm} - \frac{f_{sy}}{E_s} \right) \cdot E_{sh} + \frac{\tau_{bs1} \cdot S_r}{\emptyset_s}$$

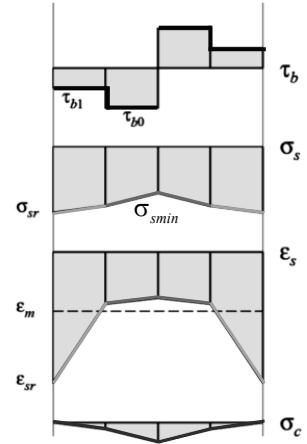

According to the Tension Chord Model, the calculation of the crack width in Regime II (elastic-plastic) leads to rather complex expressions due to the changing bond shear stress and the bilinear stress-strain-relationship of the reinforcing steel.

As a reasonable approximation, the strains in the concrete can be neglected and the crack width is determined from the average steel strains (see above), which allows for a direct relationship between the steel stress in the reinforcing bar and the crack width.

## Hybrid reinforcement (SFRC and conventional reinforcing bars)

### Critical fibre residual tensile stress

- Addition of steel fibres has favourable effects:
  - Increase in ultimate load
  - Reduced crack spacing and crack widths
  - Stiffer behaviour while reinforcing bars are elastic

### However:

- SFRC is softening
- Moderate-high fibre dosages combined with low-moderate conventional reinforcement ratios may result in a softening response of a tension chord (that would be hardening without fibres)
- A softening response occurs if at any point the differential loss in force due to the softening behaviour of SFRC is greater than the differential force increase due to hardening of the reinforcing bars
- Differentiating the tensile force and setting it to zero leads to:  $N' = A_c \frac{d}{dw} (\sigma_{s,r} \rho_s + \sigma_{cf}) = 0$

The most beneficial influence of the addition of fibres is improved serviceability and durability by decreasing crack widths at narrower crack spacings, which is caused by the residual tensile strength of SFRC transferring stresses over cracks. The contribution of the fibres usually leads to a higher ultimate load and also to a stiffer behaviour as long as the reinforcing bars are elastic.

However, as shown in slide 15, SFRC is generally a strain softening material. For certain combinations of fibres and conventional reinforcement, an overall softening response may be obtained. This occurs if the load increase due to hardening of the reinforcing bar is smaller than the softening caused by the fibres. An overall hardening behaviour is obtained if the sum of load increase (decrease) in reinforcing bars and fibres, i.e., the differential tensile force, is greater than 0. Solving this equation for the fibre content yields the so-called critical fibre content, which is a lower limit for a hardening response. For more details, see Pfy (2003) [1].

# Hybrid reinforcement (SFRC and conventional reinforcing bars)

## Experimental results: Uniaxial tension

Test setup

End-hooked fibres  
(Type 3D 65/35)

Test results vs. model

increasing fibre content (0, 30, 60 kg/m<sup>3</sup>)

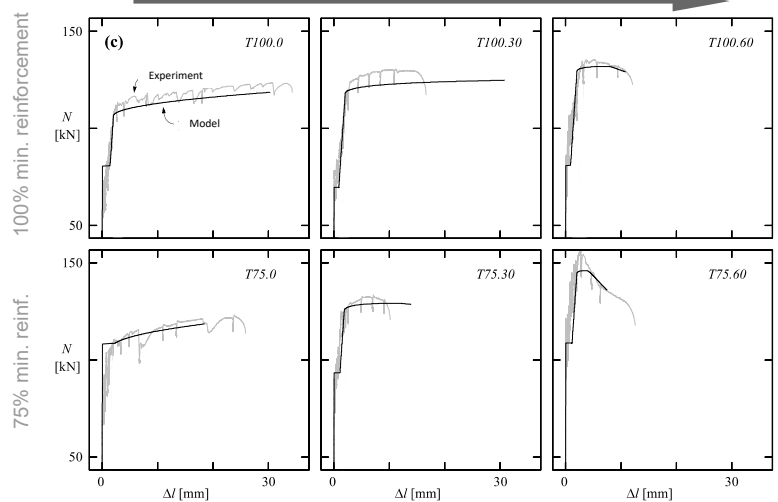
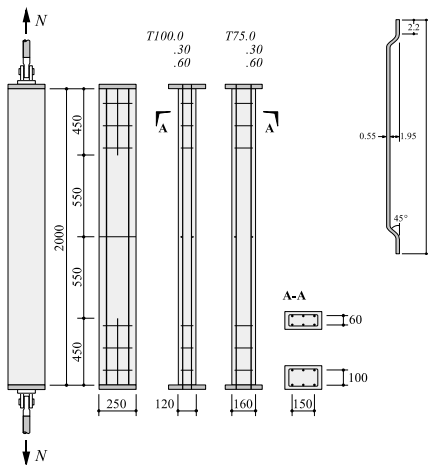

[ Source: Pfy, 2003 ]

08.12.2021

ETH Zurich | Chair of Concrete Structures and Bridge Design | Advanced Structural Concrete

31

The Figure shows experimental results of tension ties reinforced with conventional reinforcing bars and a variable dosage of end-hooked fibres.

The specimens were loaded in uniaxial tension. The two series differ in the amount of conventional reinforcement. Whereas the first series contained the minimum reinforcement, the second series was under-reinforced at 75% of the minimum reinforcement. One can see that for the tension ties with no fibres, both series exhibit a hardening response after yielding. With increasing fibre content (30 and 60 kg/m<sup>3</sup>), the slope of the plastic response flattens and eventually turns into softening for the under-reinforced specimen.

# Hybrid reinforcement (SFRC and conventional reinforcing bars)

## Bending

- Same assumptions on strains and crack kinematics as for SFRC elements in *bending* (slide 21)
- Crack width is determined from the average steel strains neglecting the elongation of the concrete between the cracks
- Steel stresses are determined from the tension chord model (slide 28)

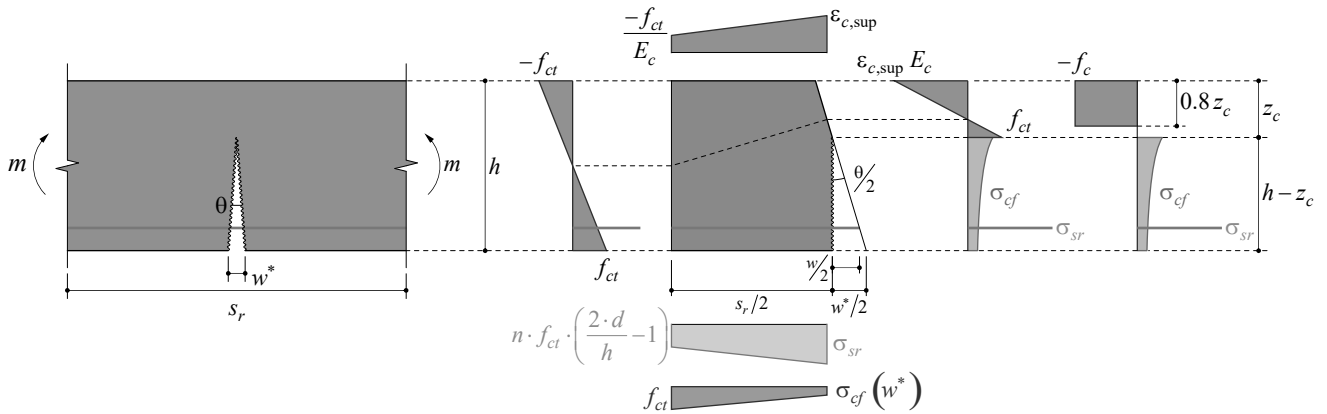

Generally, the same assumptions on strains and crack kinematics are applied for concrete members with hybrid reinforcement in bending as for SFRC elements. The crack faces are assumed to be linearly opening with a crack opening angle  $\theta$ . The crack kinematics are derived from the integration of the strains in the compression chord over the crack element. The crack spacing  $s_r$  has to be estimated; it typically lies between  $0.5$  and  $2 \cdot d$ . The uncracked concrete is assumed to be linear elastic. Similarly as for uniaxial tension, stresses from the rebar are transferred to the concrete by bond shear stresses along the reinforcing bar. The residual stress distribution in the SFRC is obtained from Pfyf' pull-out model, see slide 15.



# Hybrid reinforcement (SFRC and conventional reinforcing bars)

## Bending – simplified stress distribution in concrete

- Assuming a simplified stress distribution for the concrete in compression, the  $m$ - $\chi$ -relationship can be essentially determined from equilibrium alone, leading to a much simpler expression
- The crack spacing is determined from the modified tension chord model using a reinforcement ratio of  $\rho^*$  (see Stahlbeton I)

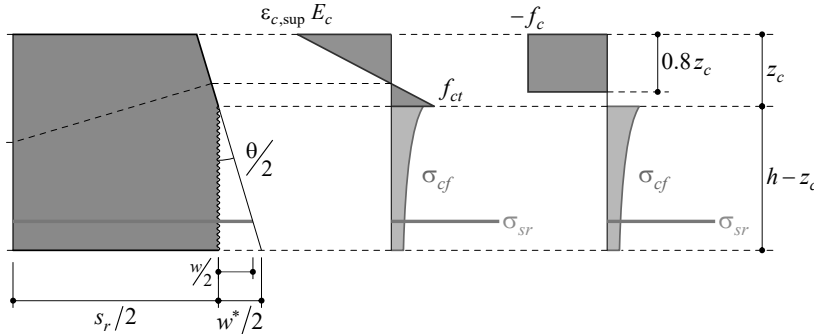

$$\sum F_H = 0: \quad a_s \cdot \sigma_{sr} + \sigma_{crm} \cdot (h - z_c) = 0.8 \cdot z_c \cdot f_c$$

$$\sum M = 0: \quad m = a_s \cdot \sigma_{sr} \cdot (d - 0.4 \cdot z_c) + \sigma_{crm} \cdot (h - z_c) \cdot (\zeta_{ct} + 0.6 \cdot z_c)$$

$$\xi = \frac{2 \cdot \theta \cdot (h - z_c)}{l}$$

Average tensile fibre stress

$$\sigma_{crm} = \frac{\sigma_{cf0}}{3} \cdot (\xi^2 - 3 \cdot \xi + 3)$$

Centroid of tensile fibre stress

$$\zeta_{ct} = (h - z_c) \cdot \frac{3 \cdot \xi^2 - 8 \cdot \xi + 6}{4 \cdot \xi^2 - 12 \cdot \xi + 12}$$

Steel stresses at crack

$$\sigma_{sr} = \text{acc. to TCM (see slide 29)}$$

$$\varepsilon_{sm} \approx \frac{w}{s_r} \quad \chi \approx \frac{w}{s_r \cdot (d - z_c)}$$

The stress distribution in the compression zone of the concrete can be approximated as rectangular stress block, leading to a much simpler formulation of the bending moment. Additionally, the strains in the concrete are neglected for the calculation of the crack width.

The relationship between steel stresses at the crack and the average steel strain can be derived from the Tension Chord Model, where the governing parameter is the reinforcement ratio  $\rho$ . An equivalent reinforcement ratio  $\rho^*$  for bending was derived by Marti (see Stahlbeton I). Accordingly, the stress of the reinforcing bar at the crack, obtained from a sectional analysis under the cracking moment, is set equal to the steel stress immediately after cracking in a tension chord with reinforcing ratio  $\rho^*$  (the reinforcement ratio of the equivalent tension chord in bending).

The assumption of a constant stress block may lead to differing results for small crack openings. However, particularly after yielding of the reinforcing bar, this error becomes negligible.

# Hybrid reinforcement (SFRC and conventional reinforcing bars)

## Critical fibre stress for SFRC members in bending

- Similar to structural members in tension, SFRC members with conventional reinforcement can exhibit a softening or hardening behaviour in bending, depending on the fibre content.
- The total response results from the superposition of the softening behaviour of SFRC and the hardening behaviour of conventionally reinforced concrete members.
- Softening occurs if  $m' = \frac{dm}{dw} < 0$
- Experimental study with 4-point-bending tests

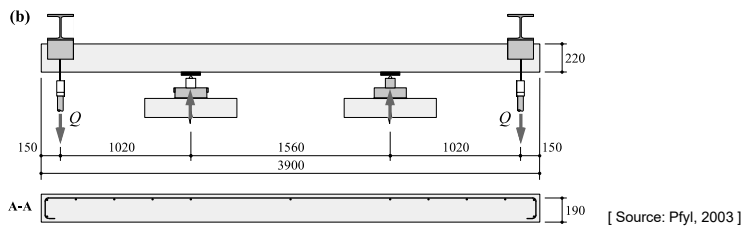

The same phenomena as in uniaxial tension apply for hybrid reinforced concrete members in bending. The ultimate load increases with higher fibre content, as well as the stiffness while the reinforcing bar remains elastic. The residual tensile stress in the cracks leads to finer cracks at narrower crack spacings.

The overall load-deformation behaviour can be considered as superposition of the hardening behaviour of the conventionally reinforced concrete member and the softening behaviour of SFRC. Particularly after the reinforcing bar starts yielding, beams with hybrid reinforcement can display a softening behaviour in bending for certain ratios of fibre dosage to conventional reinforcement content.

The following experimental results were obtained from a 4-point bending test conducted at ETH Zürich [1].

# Hybrid reinforcement (SFRC and conventional reinforcing bars)

## Experimental results: 4-point bending

Test results vs. model

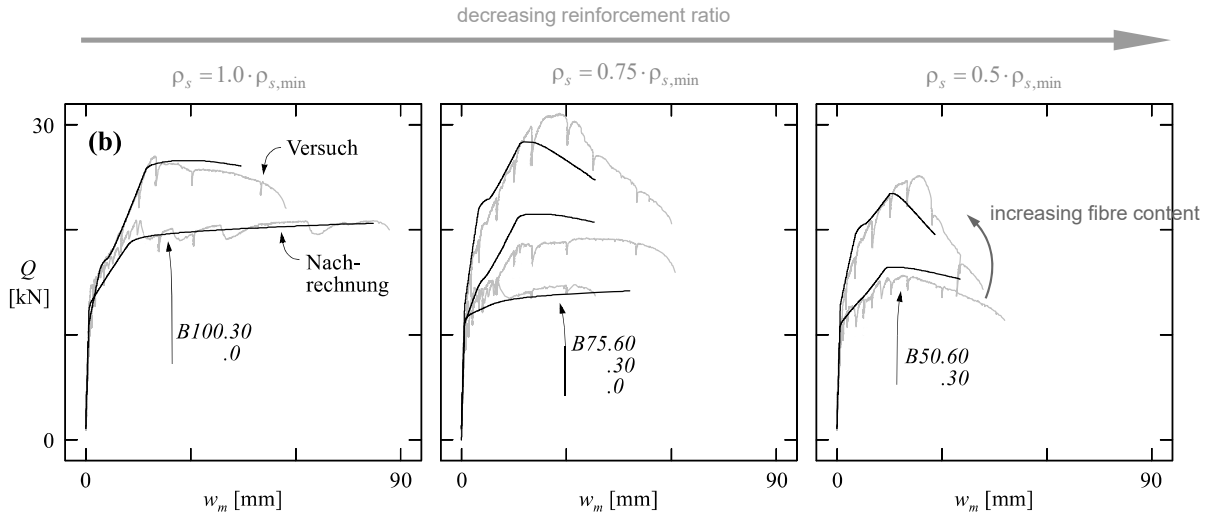

08.12.2021

ETH Zurich | Chair of Concrete Structures and Bridge Design | Advanced Structural Concrete

35

The Figure shows the load-crack opening-relationship for hybrid reinforced concrete members in bending. One can see that with increasing fibre content, the ultimate load increases, but the post-peak behaviour exhibits a softening behaviour for fibre contents higher than a certain value. The cracked-elastic response is stiffer for higher fibre contents, and the ultimate load is reached at similar crack widths.

The addition of steel fibres to the concrete mix can partially replace the conventional reinforcement. Also, its effect on finer crack widths at narrower crack spacing is beneficial for serviceability and durability. However, due to the softening behaviour of SFRC, the amount of conventional reinforcement that can be replaced is limited to a critical fibre content. For higher fibre contents, the overall response exhibits a softening behaviour and is therefore unsafe for design (accounting for moment redistribution as usual). The simplified procedure for the assessment of the bending capacity for given crack openings gives reasonable results for the estimation of hardening or softening behaviour of hybrid-reinforced concrete.

# Ultra High Performance Fibre Reinforced Concrete (UHPFRC)

## What is Ultra High Performance Fibre Reinforced Concrete?

Ultra high strength fibre reinforced concrete with a compressive strength up to 200 MPa thanks to special mix composition:

- very high cement content (ca. 3 times more than ordinary concrete) → high cost and CO<sub>2</sub> emissions
- very high fibre content (>2% of steel and/or other fibres, often «fibre cocktail» of different types) → high cost
- very low w/c-ratios (< 0.25), high density and low porosity → high durability
- small aggregate (grain) size, usually not larger than 2 mm (rather a fine mortar than “concrete”)

Advantages:

- high compressive strength
- high durability, very low permeability (watertightness)
- tensile strength (strain hardening mixes only)

Drawbacks:

- high cost (cement and fibre content, additives and admixtures, often patented technology (Ductal®, Ceracem®, ...))
- high CO<sub>2</sub>-emissions (cement content, fibre content, fine aggregates)
- high shrinkage (typically around 1‰, can be reduced with heat treatment)
- many mixes strain softening in spite of high fibre dosage

# Ultra High Performance Fibre Reinforced Concrete (UHPFRC)

## What is Ultra High Performance Fibre Reinforced Concrete?

Design aspects:

- SIA MB 2052 *Ultra-Hochleistungs-Faserbeton (UHFB) - Baustoffe, Bemessung und Ausführung* provides a basis for the dimensioning of UHPFRC
- even if strain hardening mixes are used (mandatory for structures according to MB 2052), no redistribution of action effects is allowed due to limited ductility (rupture strain in tension: few microstrains only)
- the limited ductility, high cost and CO<sub>2</sub> emissions are limiting factors for a widespread application of UHPFRC
- applications should focus on elements and parts where the high strength is really needed (lightweight prefabricated elements, connections, ...)

Some alternatives to UHPFRC (both even more expensive than UHPFRC and hardly used in large scale elements):

- SIFCON = Slurry infiltrated concrete (extremely high fibre contents are packed in the formwork, then the cement mix is poured in the spaces between the fibres)
- ECC = Engineered cementitious composites (microfibre cocktail, relatively low tensile strength, but strain hardening with high ductility, rupture strain in tension of several %)

# Ultra High Performance Fibre Reinforced Concrete (UHPFRC)

## Examples (selection)

Bridge decks (overlay): Strengthening of Viaduc de Chillon

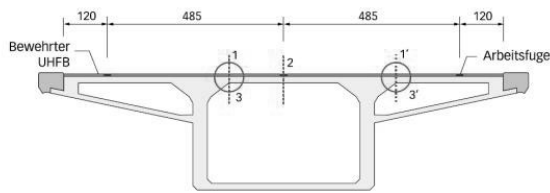

Die Verstärkung mit einer Schicht bewehrtem UHFB erhöht den Biege widerstand um 73% (Biegezug im UHFB, Schnitte 1 und 1') beziehungsweise 33% (Biegedruck im UHFB, Schnitt 2). Der Querkraftwiderstand (Schnitte 3 und 3') der verstärkten Fahrbahn im Endzustand (C30/40+UHFB) ist 20% höher als ohne Verstärkung im heutigen Zustand (C60/70).<sup>2</sup>

[ Source: espazium – Tec 21 ]



The refurbishment and strengthening of the Viaduc de Chillon faced several difficulties. In the inspection of the existing structure, it was discovered that there were first traces of on-going alkali-aggregate-reaction (AAR) which would further deteriorate the concrete over time. Possible measures included the increase of the deck height with conventional concrete, which would have critically increased the self-weight for the load-bearing behaviour in the longitudinal direction, or strengthening by external carbon fibre reinforcement lamella, which only would have increased the bending capacity but not the shear resistance of the slab.

Eventually, a 40 mm thick overlay of ultra high performance fibre reinforced concrete with additional conventional reinforcement was chosen. The overlay also seals the surface of the existing concrete, preventing water penetration and retarding the further progress of AAR.

The ultimate strength and the load-deformation behaviour were assessed in experiments conducted at HTA Freiburg.

# Ultra High Performance Fibre Reinforced Concrete (UHPFRC)

## Examples (selection)

Bridge decks (overlay): Strengthening of Viaduc de Chillon



[ Source: espazium – Tec 21 ]

# Ultra High Performance Fibre Reinforced Concrete (UHPFRC)

## Examples (selection)

Precast bridge girders: DURA Technology Sdn. Bhd.



[ Source: DURA Technolog Sdn. Bhd. ]

08.12.2021

ETH Zurich | Chair of Concrete Structures and Bridge Design | Advanced Structural Concrete

40

UHPFRC is perfectly suitable for use in pre-fabricated elements. The material parameters are easier to control in a stable environment and therefore also complex geometries can be achieved. Precast bridge girders are made from several sections. Due to the high strength of UHPFRC, slender cross section elements can be designed with correspondingly low weight, which is essential for transportation to the site.

At the construction site, the individual sections are assembled in «dry» state or with a thin mortar/epoxy joint and then post-tensioned (either internally through precast sheaths or externally using deviator elements). This procedure, well known from conventional match-cast segmental concrete bridges, is very fast and efficient since most of the construction steps are already done in the prefabrication plant.



# Ultra High Performance Fibre Reinforced Concrete (UHPFRC)

## Examples (selection)

Façade elements: Stade Jean-Bouin, Lamoureux & Ricciotti ingenierie

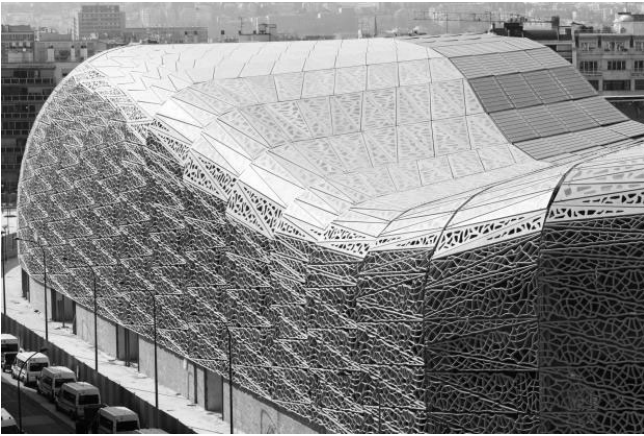

[ Source: CONSOLIS Group, consolis.com ]

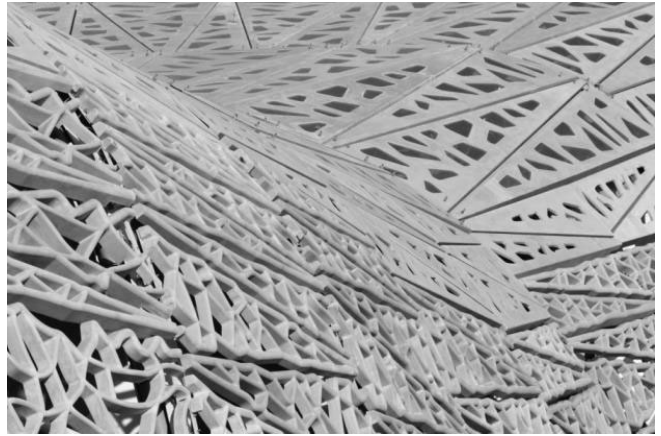

UHPFRC in façade elements allows for filigrane and complex geometries. The relatively high tensile strength (around 10 MPa) and the improved ductility allow its use in (except for the fibres) unreinforced applications for non-structural elements. However, such applications still remain rather rare due to the high material cost and the expensive formworks.

## Summary and conclusions

- Fibre reinforced concrete has been used and investigated in academia over the last five decades.
- The primary objective of adding fibres to concrete is to transmit tension across cracks.
- Practical fibre dosages lead to softening behaviour in tension (initial load drop at cracking, with subsequent gradual pull-put of the fibres in deformation controlled tests).
- When combined with conventional reinforcing bars (hybrid reinforcement), the tensile stresses carried by the fibres at the cracks result in a more pronounced tension stiffening and by this, reduced crack widths at smaller crack spacings.
- There is a limit to the amount of conventional reinforcing bars that can be replaced by fibres. Beyond this limit, structural concrete members containing fibres will display significantly reduced ductility characteristics.
- SFRC, as well as «new» materials such as UHPFRC, SIFCON and ECC have a high potential for certain applications. However, they also have some drawbacks, which need to be addressed in order to open the way for a more widespread application.

## References

- [1] Pfyl, T., *Tragverhalten von Stahlbeton*, ETH Zürich, 2003
- [2] Amin, A., *Post Cracking Behaviour of Steel Fibre Reinforced Concrete: From Material To Structure*, University of New South Wales, 2015
- [3] International Federation for Structural Concrete, *fib Model Code for Concrete Structures*, Ernst & Sohn, 2010
- [4] Markić et. al, *Strength and ductility of tension and flexural reinforced concrete members containing steel fibres: critical fibre residual stress*, ASCE, 2018
- [5] Kaufmann et. al, *Shear transfer across cracks in steel fibre reinforced concrete*, Engineering Structures, 2018
- [6] Hillerborg, *A Model for Fracture Analysis*, The Lund Institute of Technology, 1978
- [7] Sigrist, *Zum Verformungsvermögen von Stahlbetonträgern*, ETH Zürich, 1995
- [8] Hansel et. al, *Steel-fibre-reinforced segmental linings: State-of-the-art and completed projects*, Tunnel, 2011
- [9] Fehling et al, *Ultra-High Performance Concrete UHPC*, Ernst & Sohn, 2014
- [10] Brühwiler, *Stahl und Beton effizienter kombiniert*, TEC21, 2014